

User Manual

Version 1.2.3 Nov. 2024

LRA-900

(RS-232/RS-485 to LoRa Radio Modem)



Table of Contents

1. Introduction	4
1.1. Features.....	5
1.2. Specification.....	6
2. Getting Started	7
2.1. LED Indicator	8
2.2. Rotary Switch Setting.....	8
2.3. DIP Switch Setting	9
3. Software Utility	10
3.1. Install the LRA-900 Utility.....	10
3.2. Setting up the LRA-900.....	13
3.3. LRA-900 RSSI Test.....	19
Appendix A. Dimensions.....	21
Appendix B. Revision History.....	22

Important Information

Warranty

All products manufactured by ICP DAS are under warranty regarding defective materials for a period of one year, beginning from the date of delivery to the original purchaser.

Warning

ICP DAS assumes no liability for any damage resulting from the use of this product. ICP DAS reserves the right to change this manual at any time without notice. The information furnished by ICP DAS is believed to be accurate and reliable. However, no responsibility is assumed by ICP DAS for its use, not for any infringements of patents or other rights of third parties resulting from its use.

Copyright

Copyright © 2024 by ICP DAS Co., Ltd. All rights are reserved.

Trademark

Names are used for identification purpose only and may be registered trademarks of their respective companies.

Contact us

If you encounter any problems while operating this device, feel free to contact us via mail at: service@icpdas.com.

1. Introduction

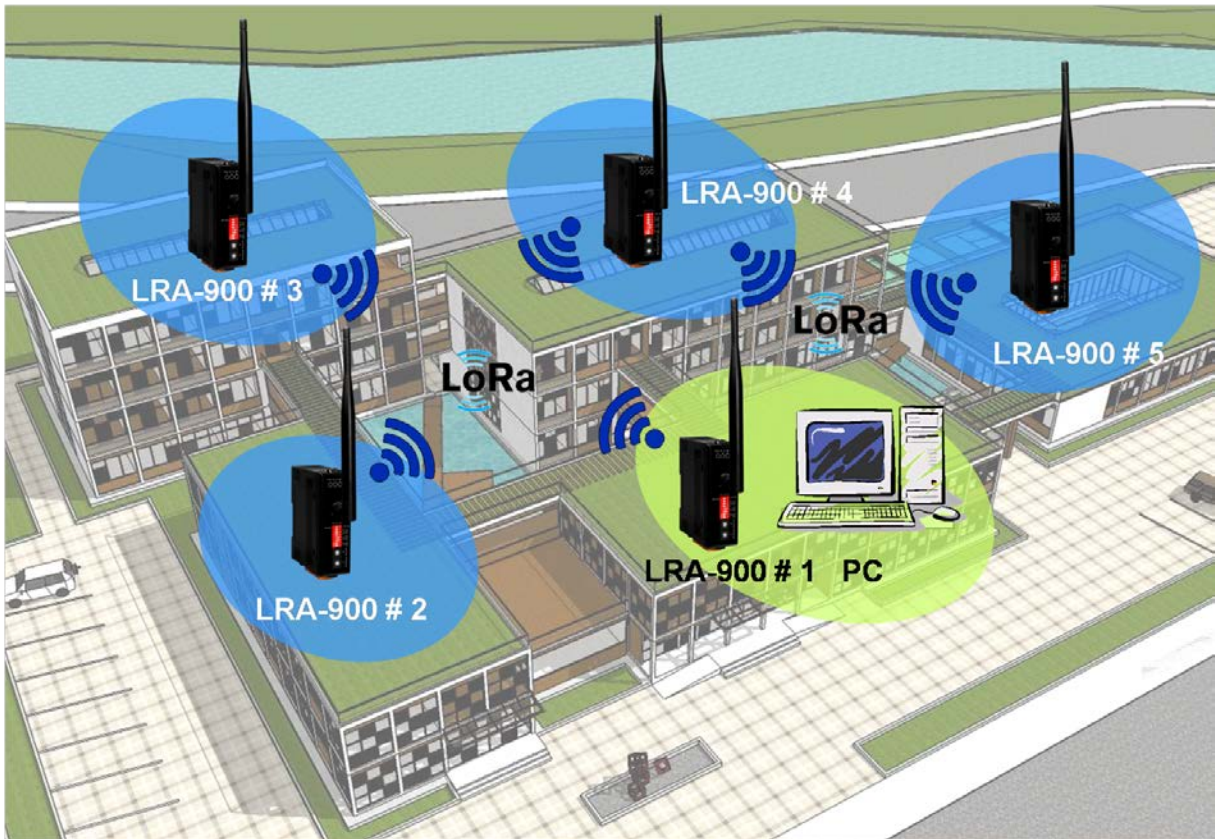

The LRA-900 is a RS-232/RS-485 to radio device designed for remote communication operating in a transparent way and exploiting the physical layer of LoRa (Long Range) transmission technology.

The LRA-900 provides a maximum line of sight (LOS) transmission distance of 1000 meters (1 km) at an RF bit rate 10,000 bps. In order to overcome the interference that may be encountered in harsh environments, the LRA-900 allows the RF transmission bit rate to be configured to a minimum of 250 bps, enhancing the capability of the modem to resist noise and other interference. Additionally, the RF channels and Group IDs are adjustable, which is helpful to avoid interference encountered when two LRA-900 networks are adjacent. The RF channels and the Group IDs can be configured in order to distinguish and control the different LRA-900 networks.

1.1. Features

- ◆ LoRa (Long Range) transmission technology
- ◆ Transparent transmission mode
- ◆ 32 RF channels (Frequency band : 864~ 871.5MHz, 915~ 922.5MHz)
- ◆ RF baud rates: 10,000 ~ 250 bps
- ◆ Wireless line of sight (LOS) transmission range of up to 1500 meters at an RF baud rate of 10,000 bps
- ◆ Provides baud rates from 1200 to 115200 bps for both the RS-232 and RS-485 interfaces
- ◆ ESD Protection: Contact +/-4 kV
- ◆ Isolation: 3000 VDC for DC-to-DC, 2500 Vrms using a photocoupler
- ◆ DIN-Rail mountable
- ◆ Operating temperature, -25 °C ~ +75 °C

1.2. Specification

RF Interface	
Radio Frequency	864~ 871.5MHz, 915~ 922.5MHz (channel: 32, recommend using 868 +/- 4 MHz)
Baud Rate	10000 ~ 250 bps
Transmission Power	15 dBm (Max.)
Antenna	2 dBi Omnidirectional Antenna
Transmission Distance	up to 1500 m (with 10,000 baud, in free field conditions)
Group ID	0~255
Protocols	Transparent transmit
Temporary Buffer Size	200 bytes
Configuration	Dip /Rotary switch or Utility tool
COM Port Interface	
RS-232	TxD, RxD and GND
RS-485	D+, D-
Baud Rate (bps)	1200 ~ 115200
Data Bit	5,6,7,8
Parity Bit	NONE, EVEN, ODD
Stop Bit	1,2
Buffer	1024 bytes
LED Indicators	
Red/ Green/ Yellow	Power / RF TxD / RF RxD Status
EMS Protection	
ESD	+/- 4 kV Contact
EFT	+/- 1 kV
Surge	+/- 1 kV
Power	
Required Supply Voltage	+10 VDC ~ +30 VDC
Power Consumption	1 W (Max.)
Mechanical	
Dimensions (W x L x H)	108 mm x 84 mm x 33 mm (not include antenna)
Installation	DIN-Rail
Environment	
Operating Temperature	-25 °C ~ +75 °C
Storage Temperature	-30 °C ~ +80 °C
Relative Humidity	10 ~ 90% RH, Non-condensing

2. Getting Started

■ Appearance

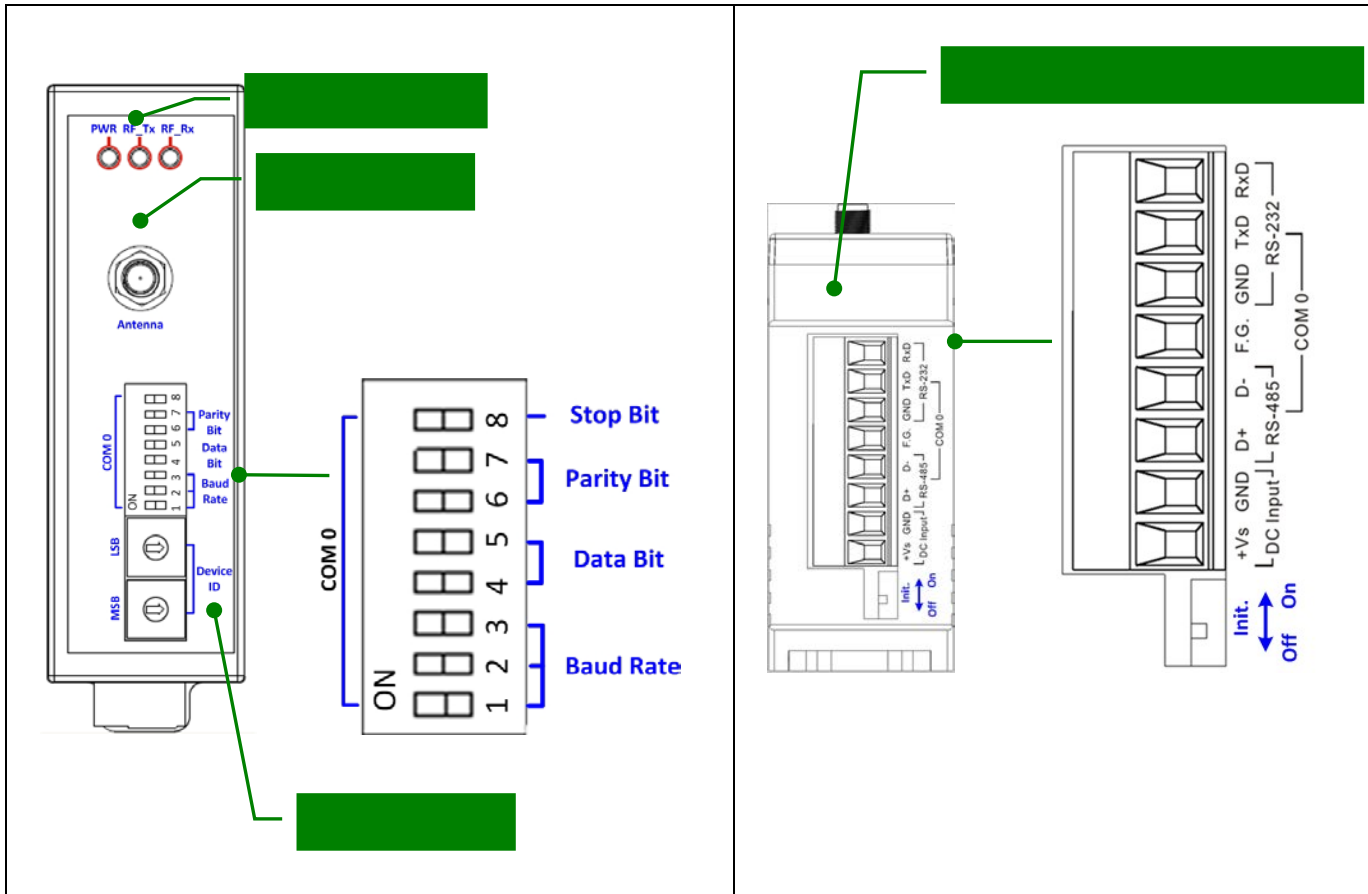

■ Pin Assignment

	Pin	Description
	+Vs	+10 ~ +30 V _{DC}
	GND	Power Ground
	D+	RS-485 Logic High
	D-	RS-485 Logic Low
	F.G.	Frame Ground
	GND	RS-232 Ground
	TxD	RS-232 Transmit Data Pin
	RxD	RS-232 Received Data Pin

2.1. LED Indicator

LED	Behavior	Description
PWR	On	+10 ~ +30 V _{DC} Power On
	Off	Power Off
RF_Tx	On	RF is transmitting data
	Off	RF is no data to transmit
RF_Rx	On	RF is receiving data
	Off	RF is no data to receive

2.2. Rotary Switch Setting

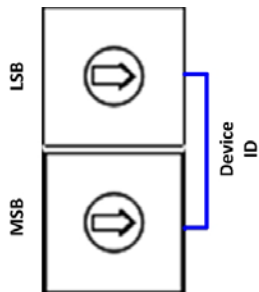
Switch Name	Description
	<p>Device ID, 0x01 ~ 0xFE</p> <p>NOTE:</p> <ul style="list-style-type: none"> ➤ Each module's "Device ID" must be different from each other. ➤ 0x00 and 0xFF are reserved for broadcast id used.

2.3. DIP Switch Setting

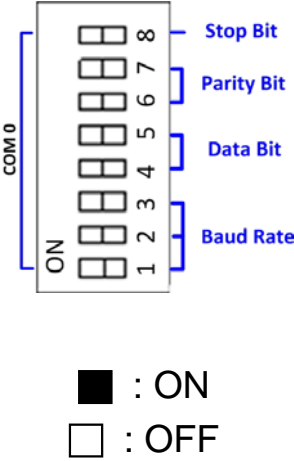
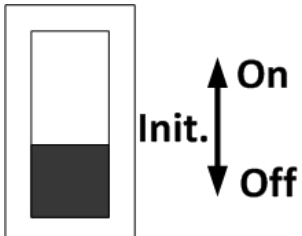
	Pin	Switch Name	Description			
			Baud Rate	1	2	3
 <p> <input checked="" type="checkbox"/> : ON <input type="checkbox"/> : OFF </p>	1 ~ 3	COM0 Baud Rate (bps)	115200	<input type="checkbox"/>	<input type="checkbox"/>	<input type="checkbox"/>
			57600	<input checked="" type="checkbox"/>	<input type="checkbox"/>	<input type="checkbox"/>
			38400	<input type="checkbox"/>	<input checked="" type="checkbox"/>	<input type="checkbox"/>
			19200	<input checked="" type="checkbox"/>	<input checked="" type="checkbox"/>	<input type="checkbox"/>
			9600	<input type="checkbox"/>	<input type="checkbox"/>	<input checked="" type="checkbox"/>
			4800	<input checked="" type="checkbox"/>	<input type="checkbox"/>	<input checked="" type="checkbox"/>
			2400	<input type="checkbox"/>	<input checked="" type="checkbox"/>	<input checked="" type="checkbox"/>
			1200	<input checked="" type="checkbox"/>	<input checked="" type="checkbox"/>	<input checked="" type="checkbox"/>
			4 ~ 5	COM0 Data Bit	Data Bit	4
	8	<input type="checkbox"/>			<input type="checkbox"/>	
7	<input checked="" type="checkbox"/>	<input type="checkbox"/>				
6	<input type="checkbox"/>	<input checked="" type="checkbox"/>				
5	<input checked="" type="checkbox"/>	<input checked="" type="checkbox"/>				
6 ~ 7	COM0 Parity Bit	Parity Bit	6	7		
		NONE	<input type="checkbox"/>	<input type="checkbox"/>		
		EVEN	<input checked="" type="checkbox"/>	<input type="checkbox"/>		
		ODD	<input type="checkbox"/>	<input checked="" type="checkbox"/>		
		Reserved	<input checked="" type="checkbox"/>	<input checked="" type="checkbox"/>		
8	COM0 Stop Bit	Parity Bit	8			
		1	<input type="checkbox"/>			
		2	<input checked="" type="checkbox"/>			
	Init / Run Mode	Init Mode: Be able to use Utility to configure via the RS-232 interface.				
		Run Mode: Use to transmit data to the RF side via COM 0 interface.				

3. Software Utility

When users want to change the “Group ID”, “LoRa frequency”, “Module operation mode” of the LRA-900, the LRA-900 Utility tool may be needed.

3.1. Install the LRA-900 Utility

Step 1: Get the LRA-900 Utility

The software is located at:

<https://www.icpdas.com/tw/download/show.php?num=6618&model=LRA-900>

Step 2: Install .NET Framework 3.5 component

The LRA-900 Utility tool requires the “.NET Framework 3.5 components”. If your PC’s environment does not have “.NET Framework 3.5 components”, it will start to install .NET Framework 3.5 components from the web site, after executing the “Setup.exe” file.

Step 3: Install Utility tool

After installing the .Net Framework components, the software will continue to install the Utility tool.

1. Click the “Next” button to continue.

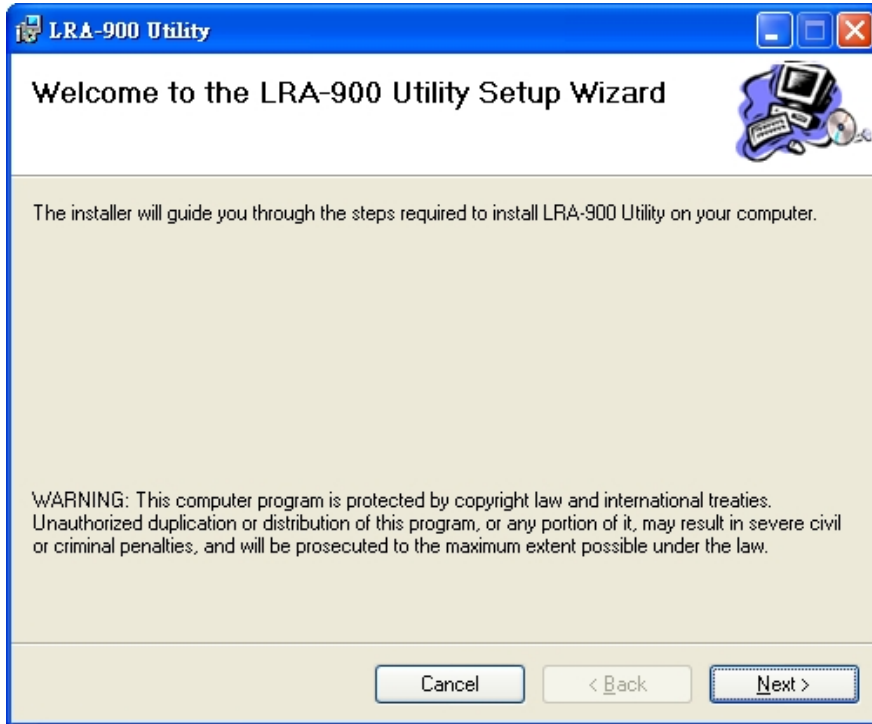

2. Select the installation path of the LRA-900 Utility and click the “Next” button.

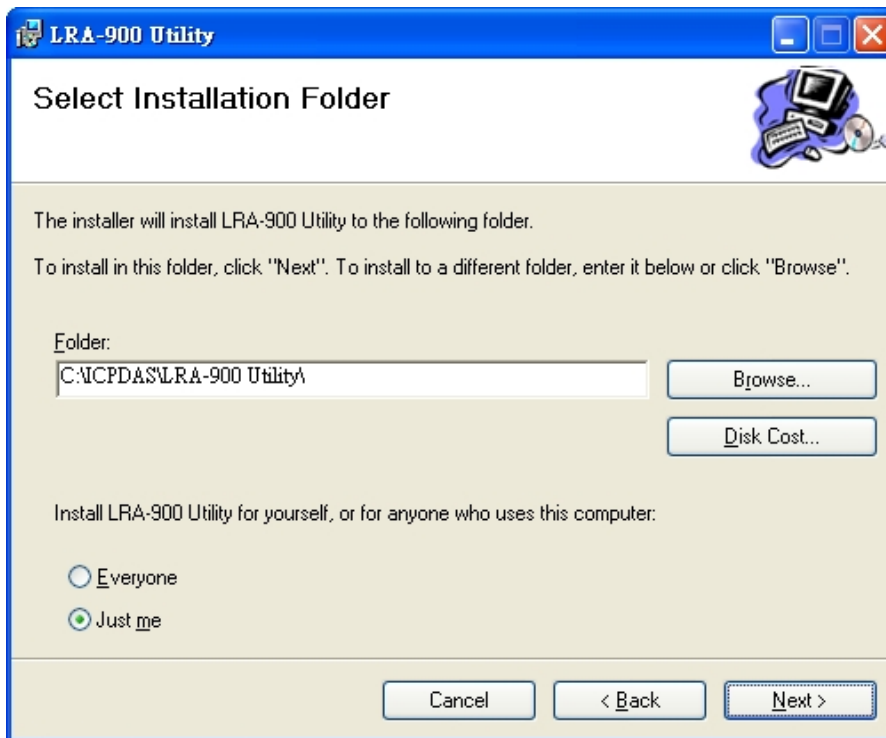

3. Confirm the installation. Click the “Next” button to start the installation

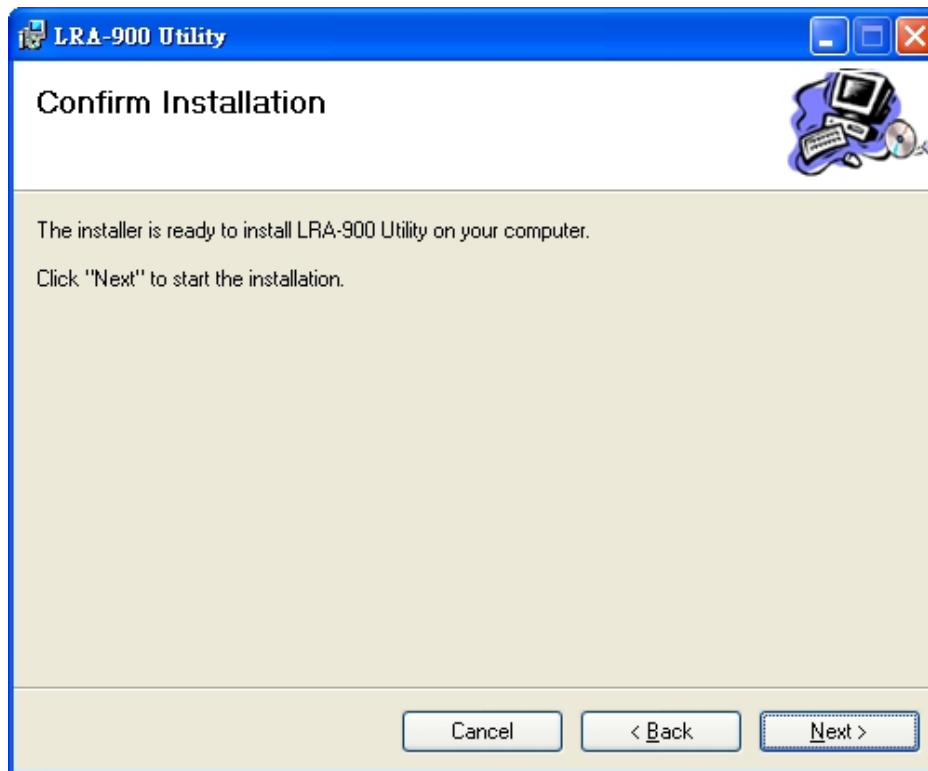

4. Installation complete. Click the “Close” button to exit

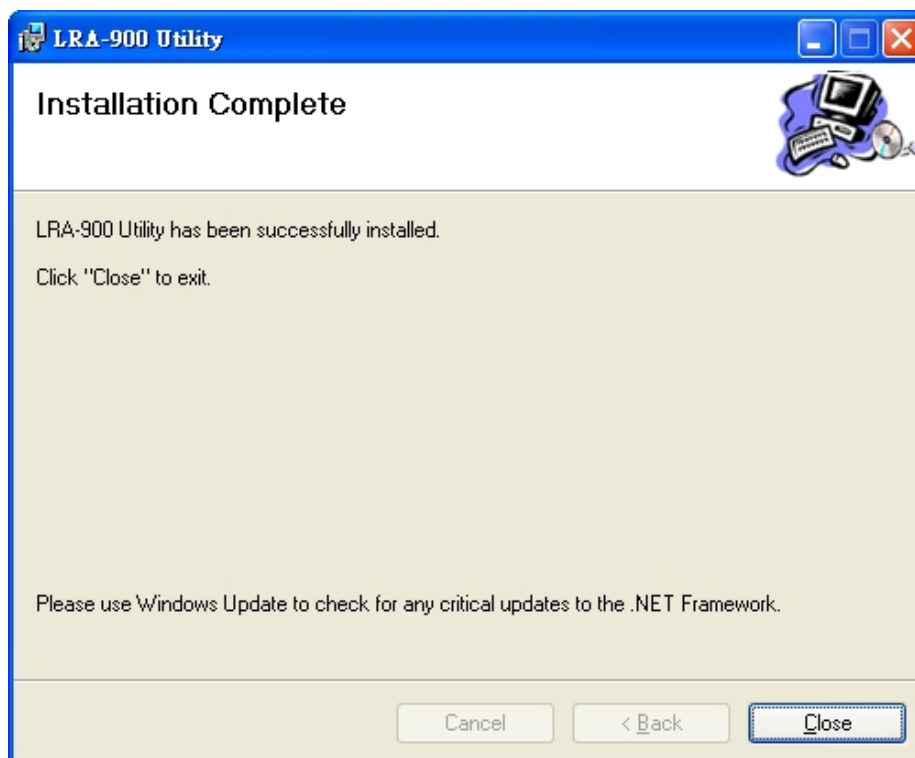

3.2. Setting up the LRA-900

After installing the utility tool, please follow the following steps to set up the communication between the Utility and the LRA-900.

Step 1: Connect the PC available COM port with the RS-232 port of the LRA-900 device via CA-0910 cable. Users can find the communication cable (CA-0910) in the product box.

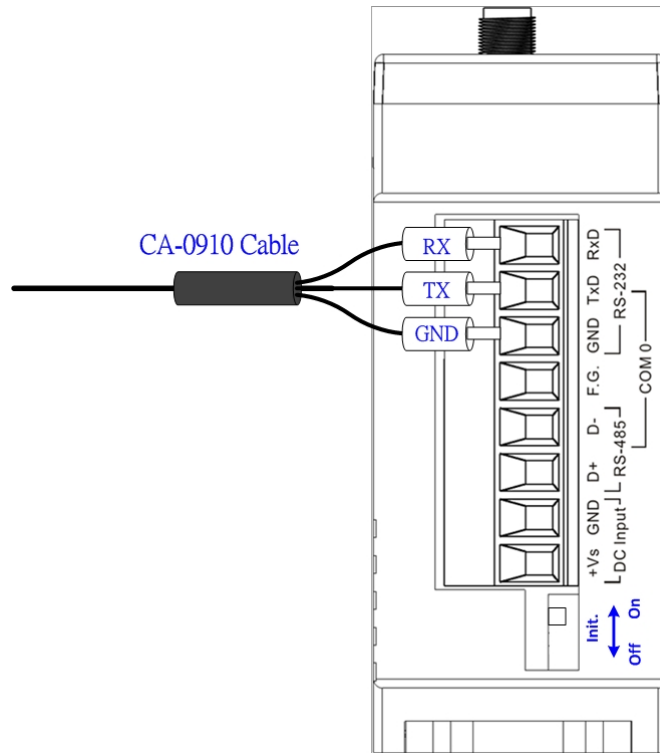

Step 2: Set the LRA-900 'Init.' Dip switch to 'On' position and reboot the module. After rebooting, the module's RF_Tx and RF_Rx led will flash ON/OFF per second.

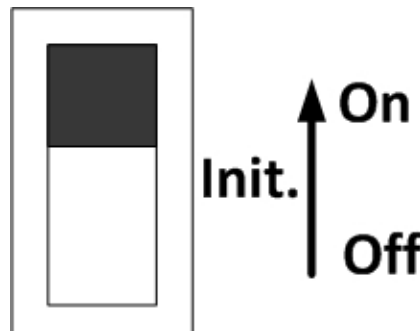

Step 3: Execute the LRA-900 Utility tool.

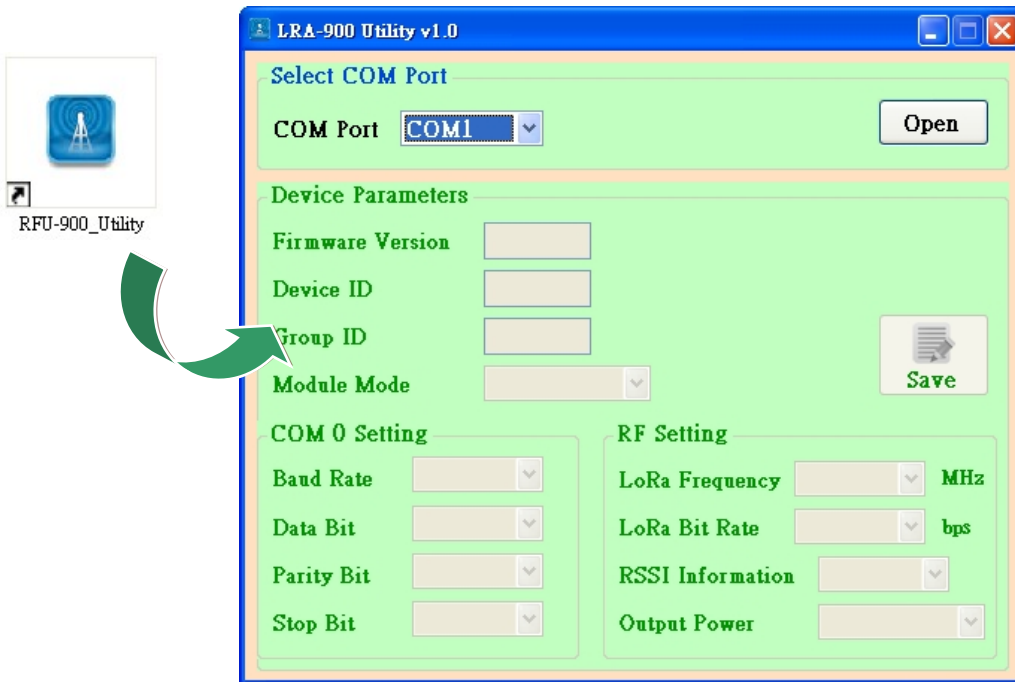

Step 4: Select the necessary PC's COM Port which connected with the LRA-900 module. And then press the 'Open' button to connect with module.

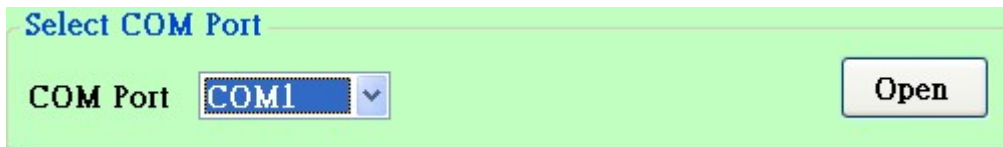

Step 5: After successfully connected with the module, all device parameters will be shown as below picture.

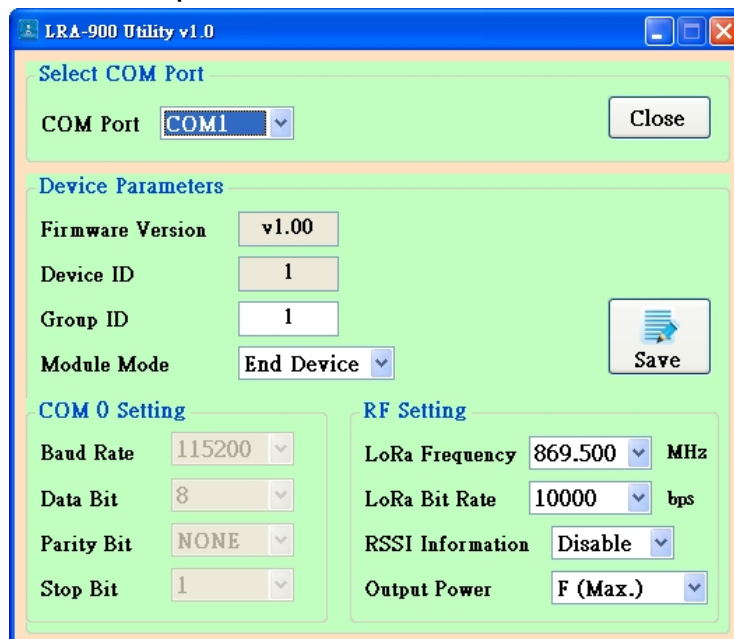



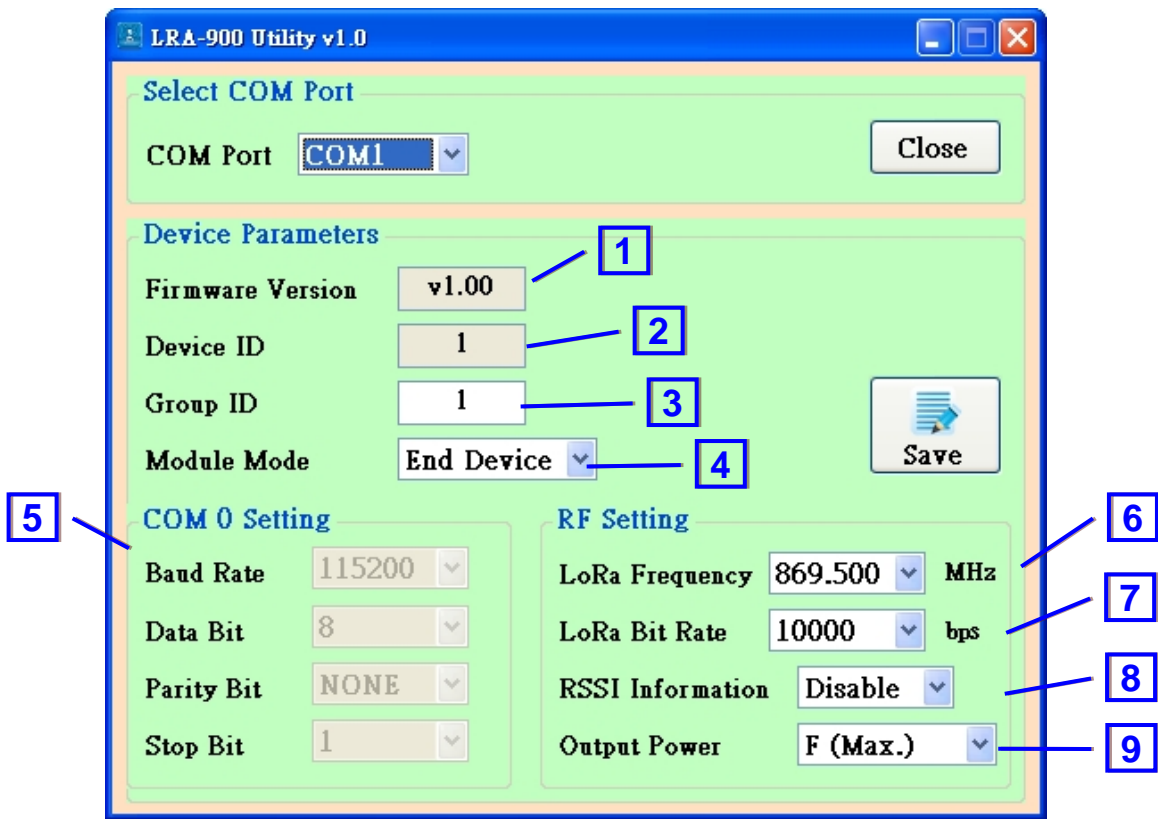

Step 6: The detail information about module's parameters are listed in below table.



Item	Name	Description						
1	Firmware Version	➤ LRA-900 firmware version						
2	Device ID	<ul style="list-style-type: none"> ➤ Device ID, valid range: 0x01 ~ 0xFE. ➤ Set by using rotary switch <table border="1" data-bbox="544 1514 1445 1890"> <thead> <tr> <th>Device ID</th> <th>Description</th> </tr> </thead> <tbody> <tr> <td>1 ~ 254 (0x01 ~ 0xFE)</td> <td>Each LRA-900's "Device ID" must be different from each other in the same RF frequency.</td> </tr> <tr> <td>0x00 and 0xFF</td> <td>0x00 and 0xFF are reserved for broadcast id used, don't set these two values.</td> </tr> </tbody> </table>	Device ID	Description	1 ~ 254 (0x01 ~ 0xFE)	Each LRA-900's "Device ID" must be different from each other in the same RF frequency.	0x00 and 0xFF	0x00 and 0xFF are reserved for broadcast id used, don't set these two values.
Device ID	Description							
1 ~ 254 (0x01 ~ 0xFE)	Each LRA-900's "Device ID" must be different from each other in the same RF frequency.							
0x00 and 0xFF	0x00 and 0xFF are reserved for broadcast id used, don't set these two values.							
3	Group ID	➤ Group ID, valid range: 0 ~ 255 (0x00 ~ 0xFF).						

		<table border="1"> <thead> <tr> <th>Group ID</th> <th>Description</th> </tr> </thead> <tbody> <tr> <td>0 ~ 254 (0x00 ~ 0xFE)</td> <td>The module has same group id (0x00 ~ 0xFE) setting can communicate with each other</td> </tr> <tr> <td>255 (0xFF)</td> <td>The module has the group id (0xFF) setting can communicate with other module which group id setting is 0x00 to 0xFF</td> </tr> </tbody> </table>	Group ID	Description	0 ~ 254 (0x00 ~ 0xFE)	The module has same group id (0x00 ~ 0xFE) setting can communicate with each other	255 (0xFF)	The module has the group id (0xFF) setting can communicate with other module which group id setting is 0x00 to 0xFF
Group ID	Description							
0 ~ 254 (0x00 ~ 0xFE)	The module has same group id (0x00 ~ 0xFE) setting can communicate with each other							
255 (0xFF)	The module has the group id (0xFF) setting can communicate with other module which group id setting is 0x00 to 0xFF							
4	Module Mode	<p>➤ End-device mode or repeater mode</p> <table border="1"> <thead> <tr> <th>Mode</th> <th>Description</th> </tr> </thead> <tbody> <tr> <td>End-device</td> <td> <ul style="list-style-type: none"> ● Message can be transmitted between UART (COM0) and RF side ● When receiving a valid LoRa signal, data will be transmitted to the UART (COM0) side. </td> </tr> <tr> <td>Repeater</td> <td> <ul style="list-style-type: none"> ● The UART (COM0) function will be disabled. ● When receiving a valid LoRa signal, data will be re-transmitted to the RF side ● Maximum support one hop </td> </tr> </tbody> </table>	Mode	Description	End-device	<ul style="list-style-type: none"> ● Message can be transmitted between UART (COM0) and RF side ● When receiving a valid LoRa signal, data will be transmitted to the UART (COM0) side. 	Repeater	<ul style="list-style-type: none"> ● The UART (COM0) function will be disabled. ● When receiving a valid LoRa signal, data will be re-transmitted to the RF side ● Maximum support one hop
Mode	Description							
End-device	<ul style="list-style-type: none"> ● Message can be transmitted between UART (COM0) and RF side ● When receiving a valid LoRa signal, data will be transmitted to the UART (COM0) side. 							
Repeater	<ul style="list-style-type: none"> ● The UART (COM0) function will be disabled. ● When receiving a valid LoRa signal, data will be re-transmitted to the RF side ● Maximum support one hop 							
5	COM 0 Setting	<p>Baud Rate:</p> <p>➤ 8 UART baud rates (115200, 57600, 38400, 19200, 9600, 4800, 2400, 1200 bps)</p> <p>Data Bit:</p> <p>➤ 4 UART data bit (5,6,7,8)</p> <p>Parity Bit:</p> <p>➤ 3 UART parity bit (NONE, EVEN, ODD)</p> <p>Stop Bit:</p> <p>➤ 2 UART stop bit (1,2)</p>						
6	LoRa Frequency	<p>➤ 32 RF frequencies (864, 864.5, 865, 865.5, 866,</p>						

		866.5, 867, 867.5, 868, 868.5, 869, 869.5, 870, 870.5, 871, 871.5, 915, 915.5, 916, 916.5, 917, 917.5, 918, 918.5, 919, 919.5, 920, 920.5, 921, 921.5, 922, 922.5 MHz)																
7	LoRa Bit Rate	<ul style="list-style-type: none"> ➤ RF bit rates (10000, 6000, 3400, 1800, 1000, 500, 250 bps). Note: The bit rate 1000 bps in firmware version v1.00 is incompatible with v1.01 or later. ➤ The maximum supported RF receive sensitivities of each baud rate are listed below. <table border="1" style="margin-left: 40px;"> <thead> <tr> <th>Baud rate (bps)</th> <th>Max. RF Receive Sensitivity (dBm)</th> </tr> </thead> <tbody> <tr> <td>10000</td> <td>-120.0</td> </tr> <tr> <td>6000</td> <td>-123.0</td> </tr> <tr> <td>3400</td> <td>-125.0</td> </tr> <tr> <td>1800</td> <td>-128.0</td> </tr> <tr> <td>1000</td> <td>-130.0</td> </tr> <tr> <td>500</td> <td>-133.0</td> </tr> <tr> <td>250</td> <td>-136.0</td> </tr> </tbody> </table>	Baud rate (bps)	Max. RF Receive Sensitivity (dBm)	10000	-120.0	6000	-123.0	3400	-125.0	1800	-128.0	1000	-130.0	500	-133.0	250	-136.0
Baud rate (bps)	Max. RF Receive Sensitivity (dBm)																	
10000	-120.0																	
6000	-123.0																	
3400	-125.0																	
1800	-128.0																	
1000	-130.0																	
500	-133.0																	
250	-136.0																	
8	RSSI information	<ul style="list-style-type: none"> ➤ Enable or disable the COM0 port to add “RegRssi (Received Signal Strength Indicator, positive number)” and “RegSNR (Signal-to-noise ratio, 2’s complement)”, 2 bytes RF signal information, at the beginning of the received LoRa data when receiving a valid LoRa message. ➤ The first byte is RegRssi, and the second byte is RegSNR. ➤ The actual RSSI (dBm) value can be calculated according to the following formula. <table border="1" style="margin-left: 40px;"> <tbody> <tr> <td>RegSNR >= 0</td> <td>RSSI(dBm) = -157 + (16/15 * RegRssi)</td> </tr> <tr> <td>RegSNR < 0</td> <td>RSSI(dBm) = -157 + (RegRssi + RegSNR * 0.25)</td> </tr> </tbody> </table>	RegSNR >= 0	RSSI(dBm) = -157 + (16/15 * RegRssi)	RegSNR < 0	RSSI(dBm) = -157 + (RegRssi + RegSNR * 0.25)												
RegSNR >= 0	RSSI(dBm) = -157 + (16/15 * RegRssi)																	
RegSNR < 0	RSSI(dBm) = -157 + (RegRssi + RegSNR * 0.25)																	

		RSSI Signal Strength (dBm)			
					
		< -100	-80 ~ -100	-60 ~ -80	> -60
		NOTE: Actual connection quality may vary depending on site conditions.			
9	RF Output power	➤ Value 0(0) ~ F(15) are mapping to the RF output power range of 2 ~ 17 dBm.			

Step 7: Press the save button to save all device parameters into module

Step 8: After setting, switch the LRA-900 “Init.” Switch to “Off” position and reboot the module.

3.3. LRA-900 RSSI Test

By using the utility tool (v1.10), user can follow the following steps to set up the communication between the Utility and the LRA-900 and check the RSSI information between these two devices.

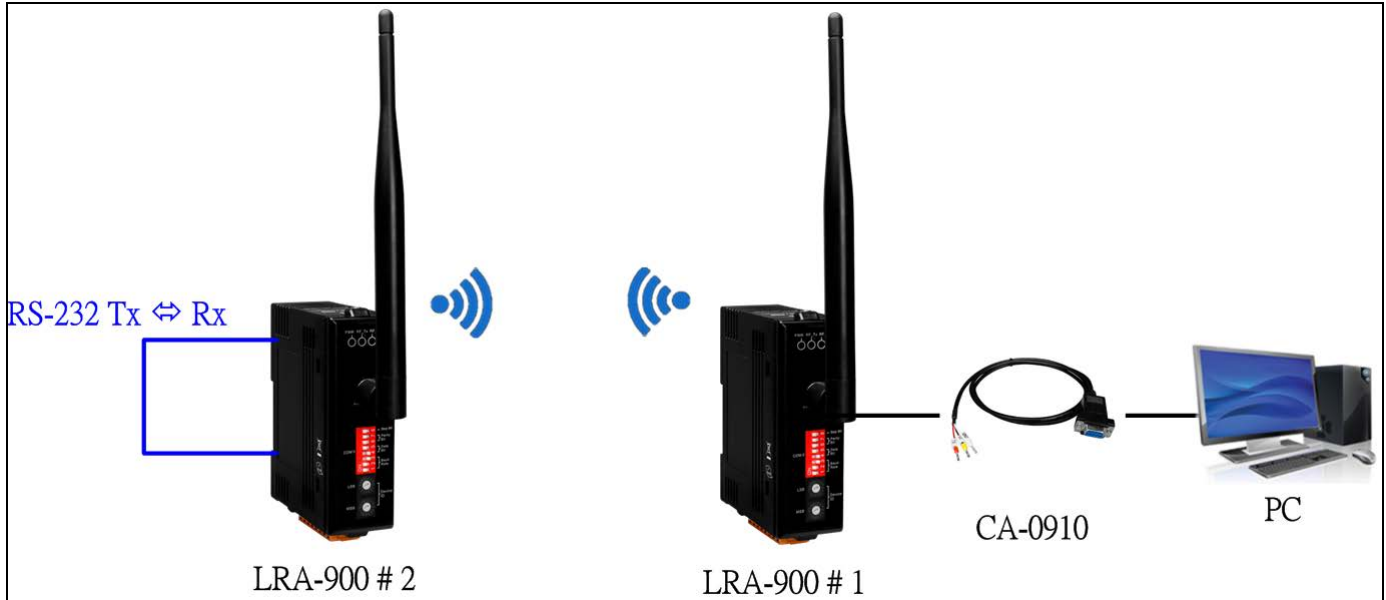



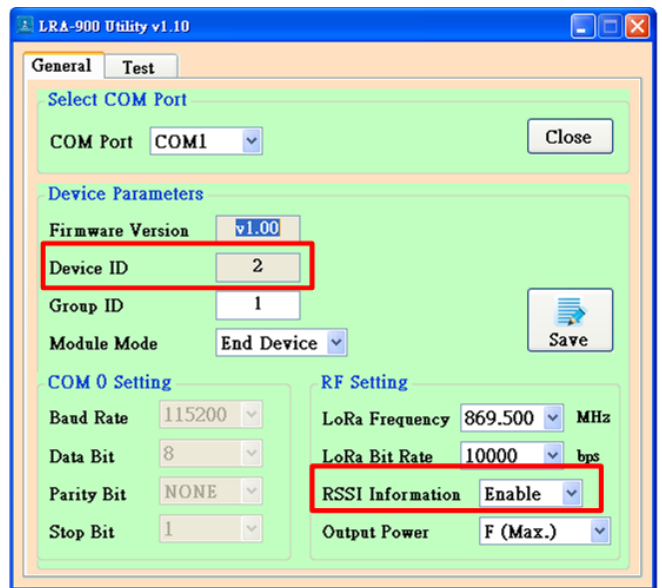
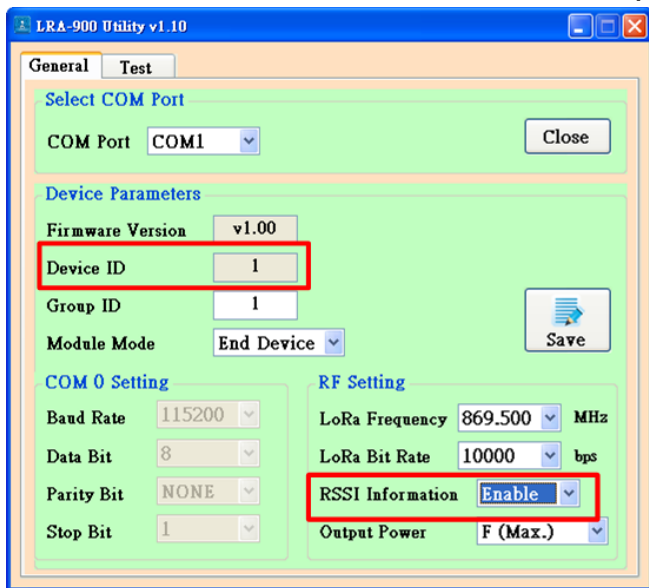

Step 1: Let the module into “Init” mode and use Utility tool to enable the two LRA-900s’ “RSSI information” parameter.

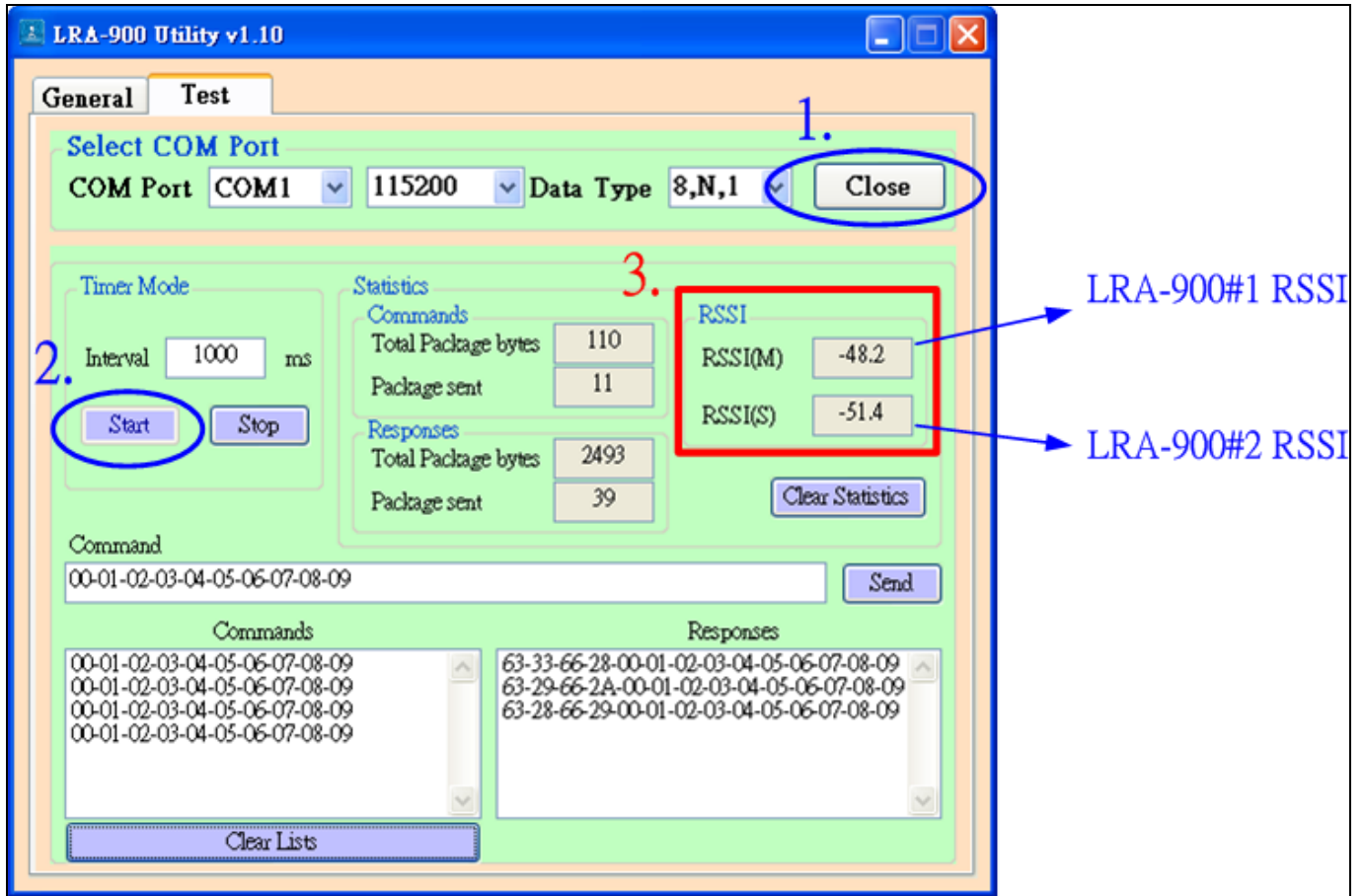

Step 2: After setting, let the two modules into “Normal” mode. Then connect the LRA-900#2’s RS-232 Tx pin with Rx pin.

Step 3: Connect PC with LRA-900#1 and use Utility tool’s “Test” mode to test the RSSI info. of these two devices.



RSSI Signal Strength (dBm)			
			
< -100	-80 ~ -100	-60 ~ -80	> -60

NOTE:

Actual connection quality may vary depending on site conditions.

Appendix A. Dimensions

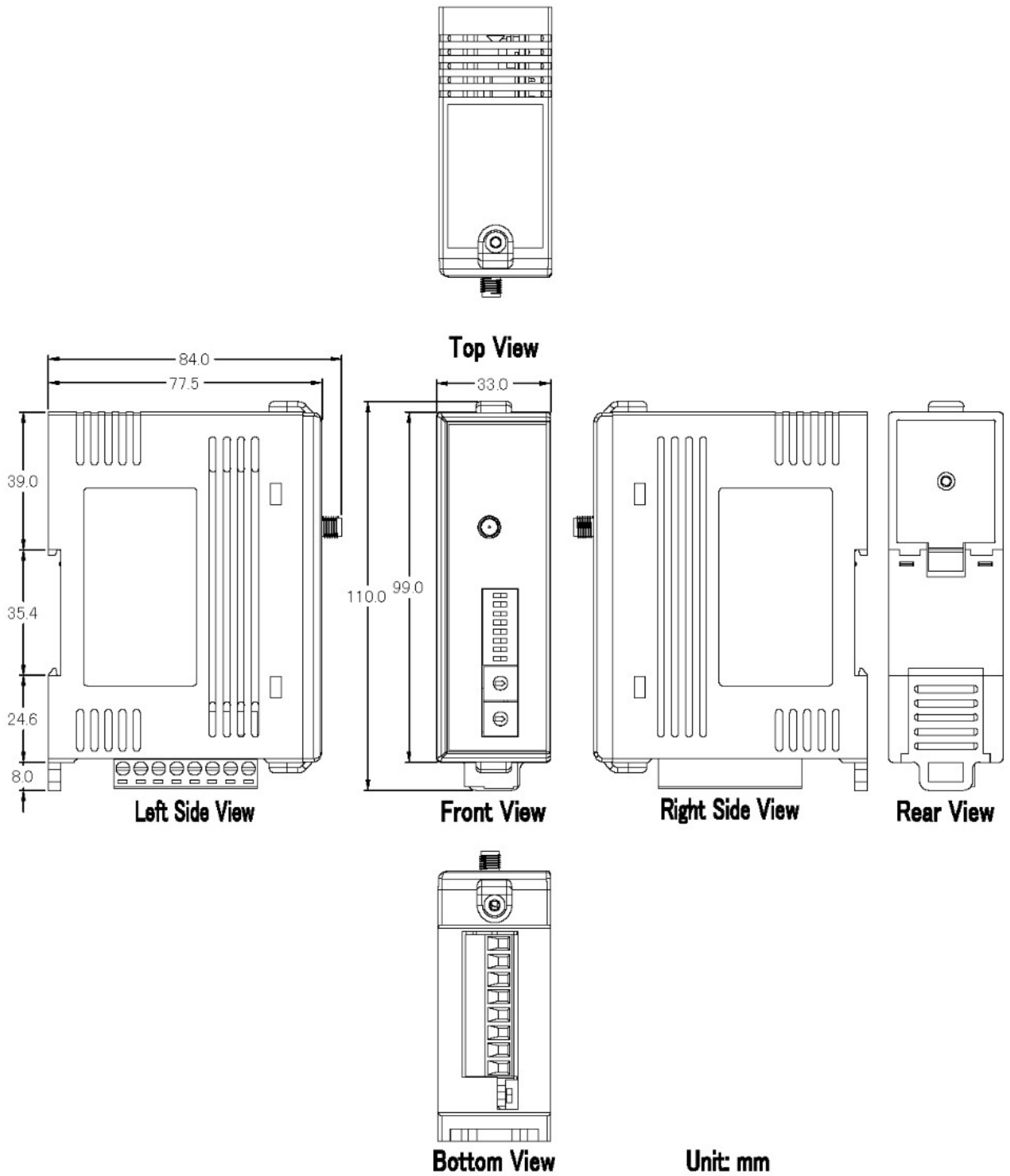

Appendix B. Revision History

This chapter provides revision history information to this document.

The table below shows the revision history.

Revision	Date	Description
1.0.0	Jan. 2018	Initial issue
1.0.1	Nov. 2019	Modify supported RF data rate description
1.1.0	Sep, 2020	Add section "3.3 LRA-900 RSSI Test"
1.2.0	Aug, 2021	<ol style="list-style-type: none">1. Add/Modify section 3.2 LoRa bit rate 1000 bps and rx sensitivity description2. Modify section 3.2 RSSI information description.
1.2.1	Apr, 2022	Remove the module repeater mode, not suggest user to use this mode.
1.2.2	Jan, 2024	<ol style="list-style-type: none">1. Section 3.2 and 3.3 add RSSI signal strength icon
1.2.3	Nov, 2024	<ol style="list-style-type: none">1. Fix the picture error on page 152. Add repeater mode function