

XV-board Series User Manual

Version 1.0.6, Jul.2025

Edited by Sunny Chiu



DIO Board

- XV107/ XV107A
- XV110
- XV111/XV111A

Relay Output Board

- XV116
- XV119

Multi-Function Board

- XV303
- XV306/XV386
- XV307
- XV308
- XV310
- XV315

Encoder/Frequency/Counter Input Board

- XV484

Warranty

All products manufactured by ICP DAS are under warranty regarding defective materials for a period of one year, beginning from the date of delivery to the original purchaser.

Warning

ICP DAS assumes no liability for any damage resulting from the use of this product. ICP DAS reserves the right to change this manual at any time without notice. The information furnished by ICP DAS is believed to be accurate and reliable. However, no responsibility is assumed by ICP DAS for its use, not for any infringements of patents or other rights of third parties resulting from its use.

Copyright

Copyright © 2015 by ICP DAS CO., LTD. All rights are reserved.

Trademark

The names used for identification only may be registered trademarks of their respective companies.

Contact US

If you have any problem, please feel free to contact us.

You can count on us for quick response.

Email: service@icpdas.com

Contents

Preface	4
XV107/XV107A	7
XV110	11
XV111/XV111A	15
XV116	17
XV119	20
XV303	22
XV306	27
XV307	32
XV308	37
XV310	42
XV315	48
XV386	54
XV484	59
Revision History	64

Preface

This manual is intended to be used as a reference for users who need to communicate with the XV-boards assembled in the VPD-132/133 series, VPD-142/143 series, WP-5231 series, LP-5231 series and WP-2241M-CE7 with Modbus protocol.

This manual assumes that the user has some knowledge of commissioning and programming of Modbus devices, including some knowledge of the Modbus protocol and your controller unit.



WP-5231/LP-5231 series



VPD-132/133 series
VPD-142/143 series

This manual can be obtained from the ICP DAS web site:
<https://www.icpdas.com/en/download/show.php?num=2271>

XV Board

FILE NAME	VERSION	FILE DATE	SIZE	NOTE	
XV-board User Manual	V1.0.5	2025-03-11	2.4 MB		
Assembly Quick Start	v1.2	2017-02-01	2.9 MB		

Contents in this Manual

Each section contains the following information for each XV-board:

- I/O Specifications
- Pin Assignments
- Wire Connections
- Modbus Register Table

The table below describes the properties of each field in a Modbus register table.

Register fields	Description
Register	The register addresses DEC: Decimal format (0 based) HEX: Hexadecimal format (0 based)
Point	The number of the I/O point
Description	The function description for the register address
Data Format	The read or write range of the I/O data
Attribute	The access type R: Read only W: Write only

Selection Guide

◆ Analog/Digital I/O Boards

Model Number	DI	DO	AI	AO
XV107 /XV107A	8-ch	8-ch	-	-
XV110	16-ch	-	-	-
XV111 /XV111A	-	16-ch	-	-
XV116	5-ch	6-ch Relay	-	-
XV119	-	9-ch Relay	-	-
XV303	4-ch	4-ch Relay	-	4-ch
XV306 /XV386	4-ch	4-ch	4-ch	-
XV307	4-ch	4-ch	-	2-ch
XV308	8-ch Universal DI/DO *		8-ch	-
XV310	4-ch	4-ch	4-ch	2-ch
XV315	4-ch	-	3-ch RTD	3-ch

* The 8 Universal DI/DO channels on the XV308 can be individually selected to be DI channels or DO channels via wire connections.

◆ Encoder/Frequency/Counter Input Boards

Model Number	Channel	Encoder	Counter	Counting Rate
XV484	4/8-ch	CW/CCW, Dir/Pulse	Up or Up/Down	200 kHz Max.

XV107/XV107A

I/O Specifications

Digital Input/Counter		XV107	XV107A
Channels		8	
Contact		Wet Contact	
Sink/Source (NPN/PNP)		Source	Sink
On Voltage Level		$+3.5 V_{DC} \sim +50 V_{DC}$	
Off Voltage Level		$+1 V_{DC} \text{ Max.}$	
Input Impedance		10 K Ω , 0.5W	
Counter	Channels	8	
	Max. Count	4,294,967,285 (32-bit) (*1)	
	Max. Input Frequency	50 Hz (*2)	
	Min. Pulse Width	10 ms	
Overvoltage Protection		$+70 V_{DC}$	
Digital Output			
Channels		8	
Type		Sink	Source
Max. Load Current		700 mA/channel	650 mA/channel
Load Voltage		$+3.5 \sim +50V_{DC}$	$+10 \sim +40V_{DC}$
Overvoltage Protection		$+60 V_{DC}$	$+47 V_{DC}$
Overload Protection		Yes	
Short-circuit Protection		Yes	
Power-on Value		Yes, Programmable	

*1, *2: with the firmware version 2.00 and later, all the DI counters are 32-bit with maximum input frequency of 50Hz. While the firmware version is 1.00, DI counters are 16-bit with maximum input frequency of 100Hz.

Pin Assignment



Internal I/O Structure

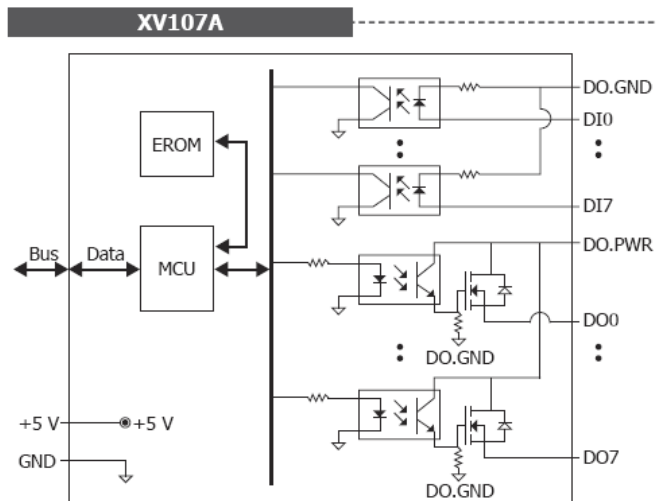
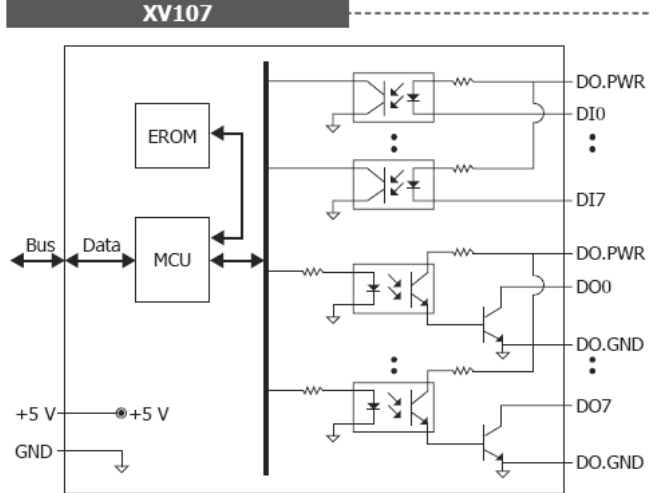

XV107



XV107A



Wire Connections

XV107		
Input Type	Readback as 1	Readback as 0
Source	+3.5 ~ 50 VDC	+1 V Max.
Output Type	Readback as 1	Readback as 0
Drive Relay		
	Resistance Load	

XV107A		
Input Type	Readback as 1	Readback as 0
Sink	+3.5 ~ 50 VDC	+1 V Max.
Output Type	Readback as 1	Readback as 0
Drive Relay		
	Resistance Load	

Modbus Register Table

Coils (0xxxx)

Register		Points	Description	Data Format	Attribute	Factory Default
DEC	HEX					
00000 : 00007	0000 : 0007	8	DO value	0: Off 1: On	R/W	-
00160 : 00167	00A0 : 00A7	8	Set the Power-on value of DO	0: Off 1: On	R/W	0
00192 : 00199	00C0 : 00C7	8	Set the trigger mode of DI counter	0: Counted at falling edge 1: Counted at rising edge	R/W	0
00263	0107	1	Clear latched DI status	1: Clear	W	-
00264	0108	1	Enable/Disable the inverse operation of DI signal	0: Disable 1: Enable	R/W	0
00265	0109	1	Enable/Disable the inverse operation of DO signal	0: Disable 1: Enable	R/W	0
00512 : 00519	0200 : 0207	8	Clear the DI counter value	1: Clear	W	-

Discrete Inputs (1xxxx)

Register		Points	Description	Data Format	Attribute
DEC	HEX				
10000 : 10007	0000 : 0007	8	DI value	0: Off 1: On	R
10064 : 10071	0040 : 0047	8	Read DI "high latch" status	0: Normal 1: Latched	R
10096 : 10103	0060 : 0067	8	Read DI "low latch" status	0: Normal 1: Latched	R

Input Register (3xxxx)

For firmware 2.00 and later: (the firmware version can be read from address 40481)

Register		Points	No. Per Point	Description	Data Format	Attribute
DEC	HEX					
30000 : 30015	0000 : 000F	8	2	DI counter value Each 32-bit counter is calculated by formula: register_high x 65536 + register_low Example: Register_low=0x5678 Register_high=0x1234 32-bit value = 0x1234 x 65536 + 0x5678 = 0x12345678	0 to 4294967295	R

For firmware 1.00: (the firmware version can be read from address 40481)

Register		Points	No. Per Point	Description	Data Format	Attribute
DEC	HEX					
30000 : 30007	0000 : 0007	8	1	16-bit DI counter value	0 to 65535	R

Holding Register (4xxxx)

Register		Points	No. Per Point	Description	Data Format	Attribute	Factory Value
DEC	HEX						
40480	01E0	1	1	Firmware version (low word)	0 to 255	R	-
40481	01E1	1	1	Firmware version (high word)	0 to 255	R	-
40482	01E2	1	1	Module name (low word), 0x0700	-	R	-
40483	01E3	1	1	Module name (high word), 0x5601	-	R	-

XV110

I/O Specifications

Digital Input/Counter		
Channels		16
Type	Dry Contact	Source
	Wet Contact	Sink/Source
On Voltage Level	Dry Contact	Close to GND
	Wet Contact	+3.5 V _{DC} ~ +50 V _D
Off Voltage Level	Dry Contact	Open
	Wet Contact	+1 V _{DC} Max.
Input Impedance		10 KΩ, 0.5W
Counter	Channels	16
	Max. Count	4,294,967,285 (32-bit) (*1)
	Max. Input Frequency	50 Hz (*2)
	Min. Pulse Width	10 ms
Overvoltage Protection		+70 V _{DC}
Effective Distance for Dry Contact		500 m Max.

*1, *2: with the firmware version 2.00 and later, all the DI counters are 32-bit with maximum input frequency of 50Hz. While the firmware version is 1.00, DI counters are 16-bit with maximum input frequency of 100Hz.

Pin Assignment

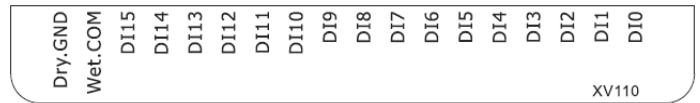

Internal I/O Structure

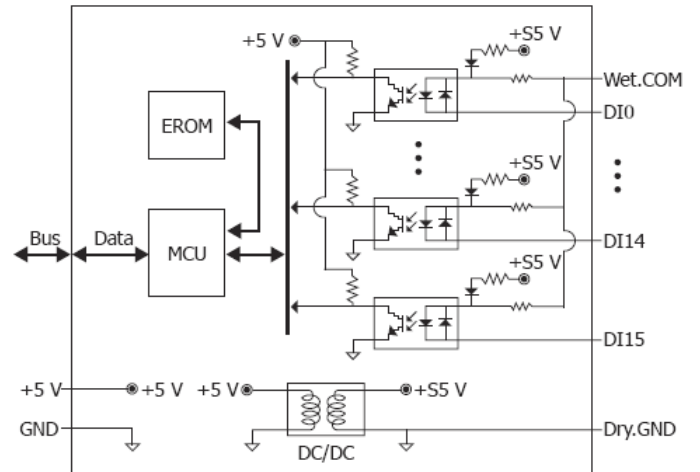

Wire Connections

Digital Input/Counter	Readback as 1	Readback as 0
Wet Contact (Sink)	+3.5 ~ +50 Vdc 	+1 Vdc Max.
	+3.5 ~ +50 Vdc 	+1 Vdc Max.
Wet Contact (Source)	+3.5 ~ +50 Vdc 	+1 Vdc Max.
	+3.5 ~ +50 Vdc 	+1 Vdc Max.
Dry Contact	Closed to Dry.GND 	Open
	Closed to Dry.GND 	Open

Modbus Register Table

Coils (0xxxx)

Register		Points	Description	Data Format	Attribute	Factory Default
DEC	HEX					
00192 : 00207	00C0 : 00CF	16	Set the trigger mode of DI counter	0: Counted at falling edge 1: Counted at rising edge	R/W	0
00263	0107	1	Clear latched DI status	1: Clear	W	-
00264	0108	1	Enable/Disable the inverse operation of DI signal	0: Disable 1: Enable	R/W	0
00512 : 00527	0200 : 020F	16	Clear the DI counter value	1: Clear	W	-

Discrete Inputs (1xxxx)

Register		Points	Description	Data Format	Attribute
DEC	HEX				
10000 : 10015	0000 : 000F	16	DI value	0: Off 1: On	R
10064 : 10079	0040 : 004F	16	Read DI "high latch" status	0: Normal 1: Latched	R
10096 : 10111	0060 : 006F	16	Read DI "low latch" status	0: Normal 1: Latched	R

Input Register (3xxxx)

For firmware 2.00 and later: (the firmware version can be read from address 40481)

Register		Points	No. Per Point	Description	Data Format	Attribute
DEC	HEX					
30000 : 30031	0000 : 001F	16	2	DI counter value Each 32-bit counter is calculated by formula: register_high x 65536 + register_low Example: Register_low=0x5678 Register_high=0x1234 32-bit value = 0x1234 x 65536 + 0x5678 = 0x12345678	0 to 4294967295	R

For firmware 1.00: (the firmware version can be read from address 40481)

Register		Points	No. Per Point	Description	Data Format	Attribute
DEC	HEX					
30000 : 30015	0000 : 000F	16	1	16-bit DI counter value	0 to 65535	R

Holding Register (4xxxx)

Register		Points	No. Per Point	Description	Data Format	Attribute	Factory Value
DEC	HEX						
40480	01E0	1	1	Firmware version (low word)	0 to 255	R	-
40481	01E1	1	1	Firmware version (high word)	0 to 255	R	-
40482	01E2	1	1	Module name (low word), 0x1000	-	R	-
40483	01E3	1	1	Module name (high word), 0x5601	-	R	-

XV111/XV111A

I/O Specifications

Digital Output	XV111	XV111A
Channels	16	
Type	Sink	Source
Max. Load Current	600 mA/channel	
Load Voltage	+3.5 ~ +50 V _{DC}	+10 ~ +40 V _{DC}
Overvoltage Protection	+60 V _{DC}	+47 V _{DC}
Overload Protection	Yes	
Short-circuit Protection	Yes	
Power-on Value	Yes, Programmable	

Pin Assignment

DO.GND	DO.PWR	DO15	DO14	DO13	DO12	DO11	DO10	DO9	DO8	DO7	DO6	DO5	DO4	DO3	DO2	DO1	DO0
XV111 / XV111A																	

Internal I/O Structure

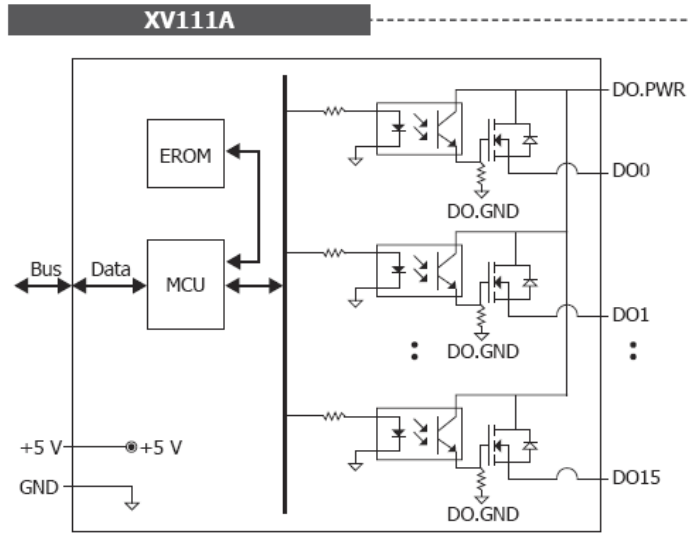
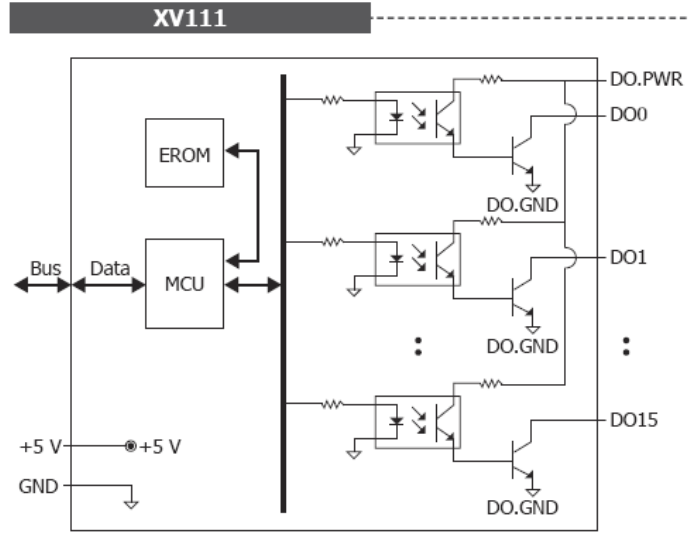

XV111



XV111A

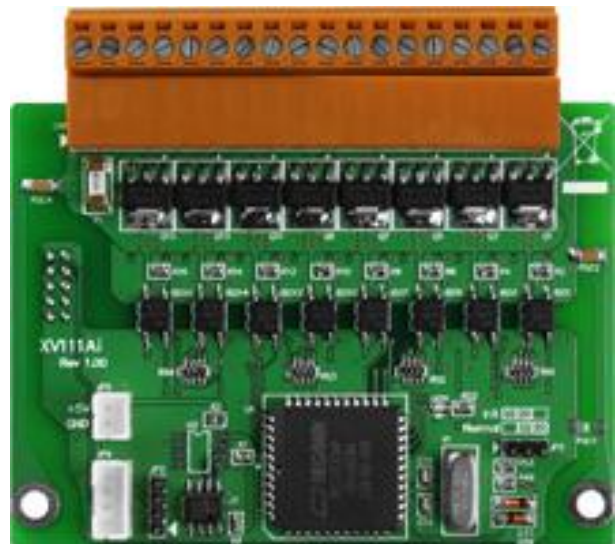

Wire Connections

XV111		
Output Type	Readback as 1	Readback as 0
Drive Relay		
Resistance Load		

XV111A		
Output Type	Readback as 1	Readback as 0
Drive Relay		
Resistance Load		

Modbus Register Table

Coils (0xxxx)

Register		Points	Description	Data Format	Attribute	Factory Default
DEC	HEX					
00000 : 00015	0000 : 000F	16	DO value	0: Off 1: On	R/W	-
00160 : 00175	00A0 : 00AF	16	Set the Power-on value of DO	0: Off 1: On	R/W	0
00265	0109	1	Enable/Disable the inverse operation of DO signal	0: Disable 1: Enable	R/W	0

Holding Register (4xxxx)

Register		Points	No. Per Point	Description	Data Format	Attribute	Factory Value
DEC	HEX						
40480	01E0	1	1	Firmware version (low word)	0 to 255	R	-
40481	01E1	1	1	Firmware version (high word)	0 to 255	R	-
40482	01E2	1	1	Module name (low word), 0x1100	-	R	-
40483	01E3	1	1	Module name (high word), 0x5601	-	R	-

XV116

I/O Specifications

Digital Input/Counter			
Channels	5		
Contact	Wet Contact		
Sink/Source (NPN/PNP)	Sink/Source		
On Voltage Level	+3.5 V _{DC} ~ +50 V _{DC}		
Off Voltage Level	+1 V _{DC} Max.		
Input Impedance	10 KΩ, 0.5W		
Counter	Channels	5	
	Max. Count	4,294,967,285 (32-bit) (*1)	
	Max. Input Frequency	50 Hz (*2)	
	Min. Pulse Width	10 ms	
Overvoltage Protection	+70 V _{DC}		
Digital Output			
Channels	2 (Channel 0,1)	4 (Channel 2 ~ 5)	
Type	Signal Relay	Power Relay	
Form A Relay	Contact Rating	2 A @ 30 V _{DC} 0.24A@220V _{DC} 0.25A@250V _{AC}	6A @ 35V _{DC} 6A@240V _{AC}
	Min. Contact Load	10mA@20 mV	100mA@ ≥ 12 V
	Contact Material	Silver Nickel, Gold-covered	Silver Cadmium Alloy
	Operate Time	3 ms (typical)	5 ms (typical)
	Release Time	4 ms (typical)	1 ms (typical)
	Mechanical Endurance	10 ⁸ ops.	30 X 10 ⁶ ops.
	Electrical Endurance	2 X 10 ⁵ ops.	1 X 10 ⁵ ops.
Power-on Value	Yes, Programmable		

*1, *2: with the firmware version 2.00 and later, all the DI counters are 32-bit with maximum input frequency of 50Hz. While the firmware version is 1.00, DI counters are 16-bit with maximum input frequency of 100Hz.

Pin Assignment

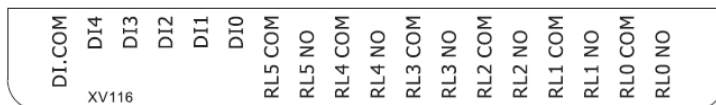

Internal I/O Structure

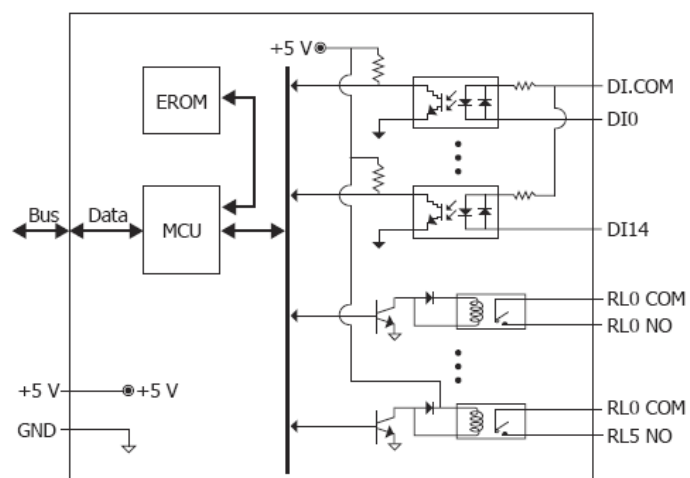

Wire Connections

Digital Input/Counter	Readback as 1	Readback as 0
Wet Contact (Sink)	+3.5 ~ +50 VDC 	+1 VDC Max.
	Wet Contact (Source)	+3.5 ~ +50 VDC
Power Relay		Readback as 1
Relay Output		

Modbus Register Table

Coils (0xxxx)

Register		Points	Description	Data Format	Attribute	Factory Default
DEC	HEX					
00000 : 00005	0000 : 0005	6	DO value	0: Off 1: On	R/W	-
00160 : 00165	00A0 : 00A5	6	Set the Power-on value of DO	0: Off 1: On	R/W	0
00192 : 00196	00C0 : 00C4	5	Set the trigger mode of DI counter	0: Counted at falling edge 1: Counted at rising edge	R/W	0
00263	0107	1	Clear latched DI status	1: Clear	W	-
00264	0108	1	Enable/Disable the inverse operation of DI signal	0: Disable 1: Enable	R/W	0
00265	0109	1	Enable/Disable the inverse operation of DO signal	0: Disable 1: Enable	R/W	0
00512 : 00516	0200 : 0204	5	Clear the DI counter value	1: Clear	W	-

Discrete Inputs (1xxxx)

Register		Points	Description	Data Format	Attribute
DEC	HEX				
10000 : 10004	0000 : 0004	5	DI value	0: Off 1: On	R
10064 : 10068	0040 : 0044	5	Read DI "high latch" status	0: Normal 1: Latched	R
10096 : 10100	0060 : 0064	5	Read DI "low latch" status	0: Normal 1: Latched	R

Input Register (3xxxx)

For firmware 2.00 and later: (the firmware version can be read from address 40481)

Register		Points	No. Per Point	Description	Data Format	Attribute
DEC	HEX					
30000 : 30009	0000 : 0009	5	2	DI counter value Each 32-bit counter is calculated by formula: register_high x 65536 + register_low Example: Register_low=0x5678 Register_high=0x1234 32-bit value = 0x1234 x 65536 + 0x5678 = 0x12345678	0 to 4294967295	R

For firmware 1.00: (the firmware version can be read from address 40481)

Register		Points	No. Per Point	Description	Data Format	Attribute
DEC	HEX					
30000 : 30004	0000 : 0004	5	1	16-bit DI counter value	0 to 65535	R

Holding Register (4xxxx)

Register		Points	No. Per Point	Description	Data Format	Attribute	Factory Value
DEC	HEX						
40480	01E0	1	1	Firmware version (low word)	0 to 255	R	-
40481	01E1	1	1	Firmware version (high word)	0 to 255	R	-
40482	01E2	1	1	Module name (low word), 0x1600	-	R	-
40483	01E3	1	1	Module name (high word), 0x5601	-	R	-

XV119

I/O Specifications

Digital Output		
Channels	9	
Type	Signal Relay	
Form A Relay	Contact Rating	2 A @ 30 VDC 0.24 A @ 220 VDC 0.25 A @ 250 VAC
	Contact Material	Silver Nickel, Gold-covered
	Operate Time	3 ms (typical)
	Release Time	4 ms (typical)
	Mechanical Endurance	1 X 10 ⁸ ops.
	Electrical Endurance	2 X 10 ⁵ ops.
Power-on Value	Yes, Programmable	

Pin Assignment

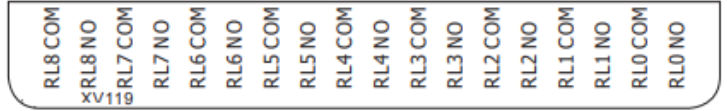

Internal I/O Structure

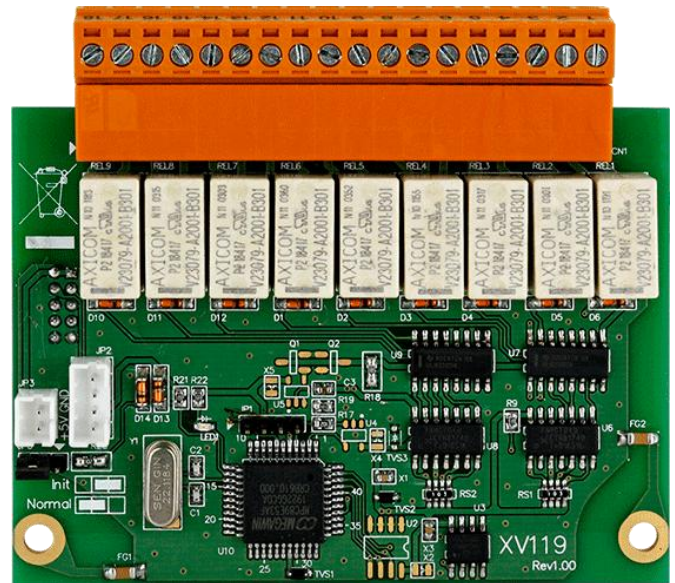
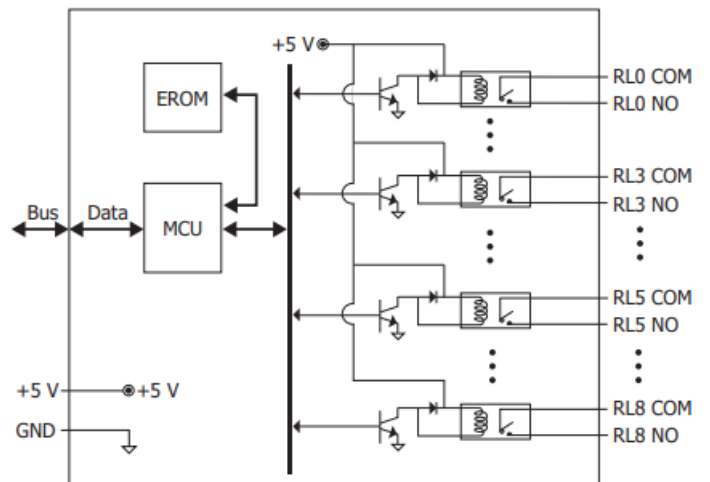

Wire Connections

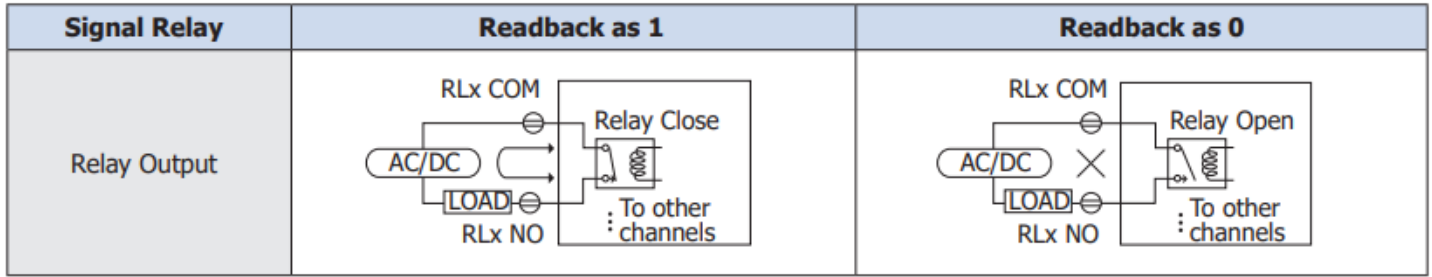

Modbus Register Table

Coils (0xxxx)

Register		Points	Description	Data Format	Attribute	Factory Default
DEC	HEX					
00000 : 00008	0000 : 0008	9	DO value	0: Off 1: On	R/W	-
00160 : 00168	00A0 : 00A8	9	Set the Power-on value of DO	0: Off 1: On	R/W	0
00263	0107	1	Clear latched DO status	1: Clear	W	-
00265	0109	1	Enable/Disable the inverse operation of DO signal	0: Disable 1: Enable	R/W	0

Discrete Inputs (1xxxx)

Register		Points	Description	Data Format	Attribute
DEC	HEX				
10064 : 10072	0040 : 0048	9	Read High Latched value of DO	0: Normal 1: Latched	R
10096 : 10104	0060 : 0068	9	Read Low Latched value of DO	0: Normal 1: Latched	R

Holding Register (4xxxx)

Register		Points	No. Per Point	Description	Data Format	Attribute	Factory Value
DEC	HEX						
40480	01E0	1	1	Firmware version (low word)	0 to 255	R	-
40481	01E1	1	1	Firmware version (high word)	0 to 255	R	-
40482	01E2	1	1	Module name (low word), 0x1900	-	R	-
40483	01E3	1	1	Module name (high word), 0x5601	-	R	-

XV303

I/O Specifications

Analog Output		
Channels	4	
Type	0 V ~ +5 V, ± 5 V, 0 V ~ +10 V, ± 10 V, 0 mA~ 20 mA, 4 mA~ 20 mA (Jumper Selectable)	
Resolution	12-bit	
Accuracy	$\pm 0.1\%$	
Voltage Output Capability	10 V @ 20 mA	
Current Load Resistance	500 Ω	
Power-on Value	Yes, Programmable	
Individual Channel Configuration	Yes	
Digital Input/Counter		
Channels	4	
Type	Wet Contact	
Sink/Source (NPN/PNP)	Sink/Source	
On Voltage Level	$+3.5 V_{DC} \sim +50 V_{DC}$	
Off Voltage Level	$+1 V_{DC}$ Max.	
Input Impedance	10 K Ω , 0.5W	
Counter	Channels	4
	Max. Count	4,294,967,285 (32-bit)
	Max. Input Frequency	50 Hz
	Min. Pulse Width	10 ms
Overvoltage Protection	$+70 V_{DC}$	
Relay Output		
Channels	4	
Type	Power Relay	
Form A Relay	Contact Rating	6 A @ 35 V_{DC} 6 A @ 240 V_{AC}
	Min. Contact Load	100 mA @ ≥ 12 V
	Contact Material	Silver Cadmium Alloy
	Operate Time	5 ms (typical)
	Release Time	1 ms (typical)
	Mechanical Endurance	30 X 10 ⁶ ops.
	Electrical Endurance	1 X 10 ⁵ ops.
Power-on Value	Yes, Programmable	

Pin Assignment



Internal I/O Structure

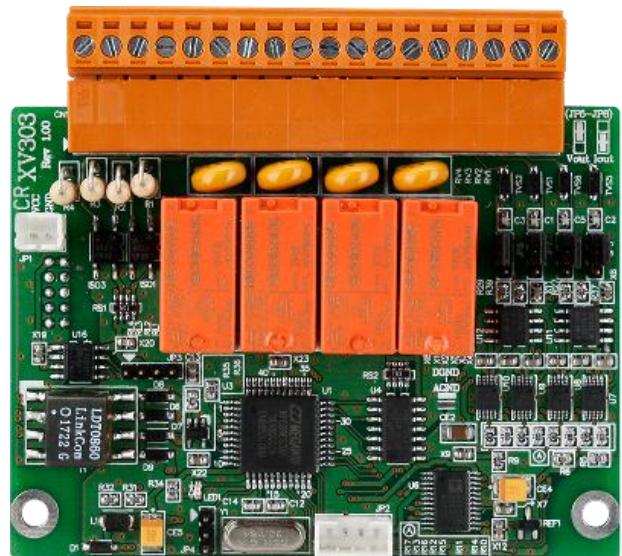
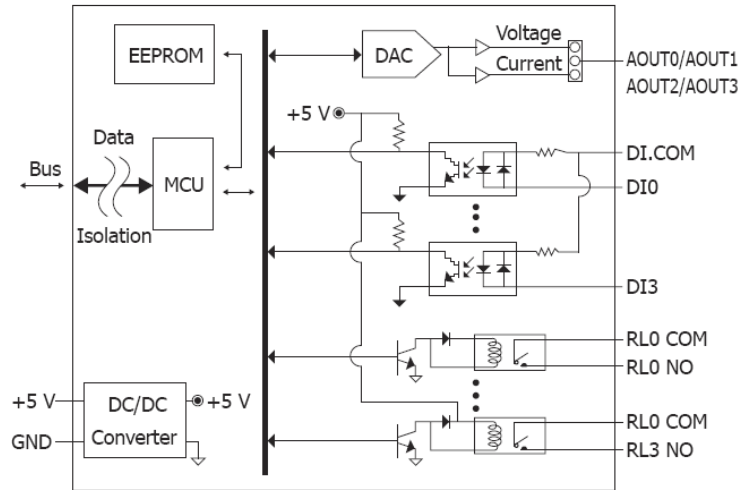

Wire Connections

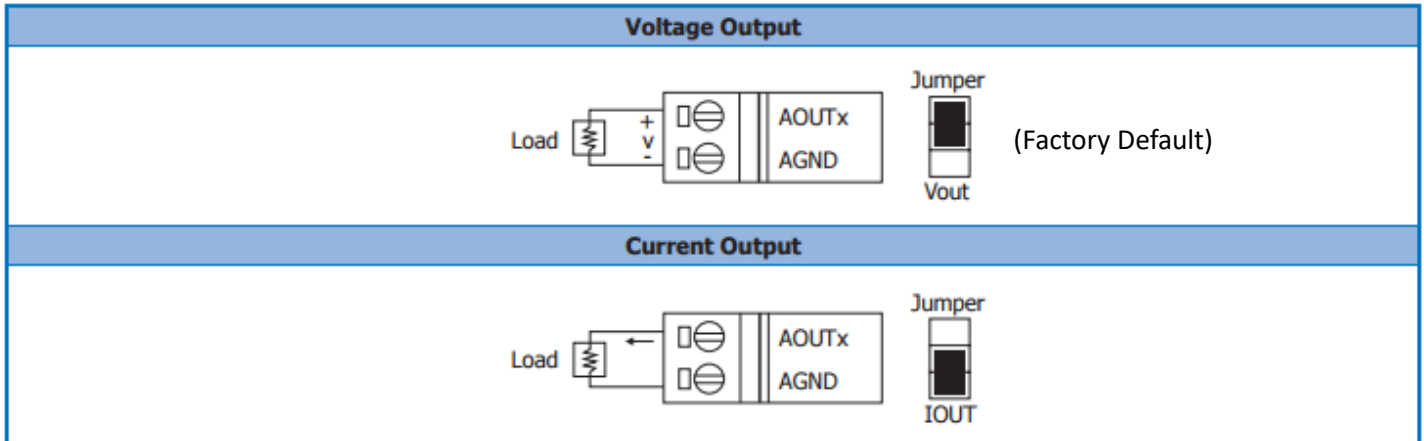

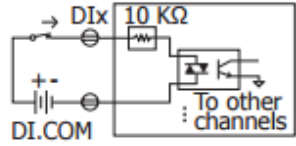
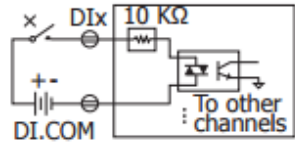
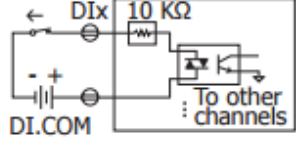
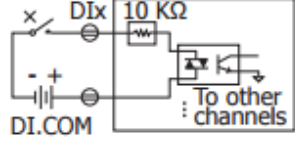
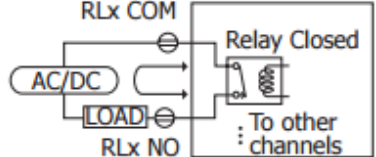
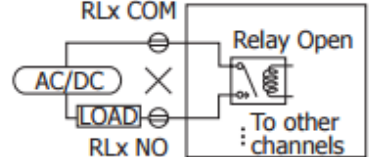
Digital Input/Counter	Readback as 1	Readback as 0
	+3.5 ~ +50 VDC	+1 VDC Max.
Wet Contact (Sink)		
	+3.5 ~ +50 Vdc	+1 VDC Max.
Wet Contact (Source)		
Power Relay	Readback as 1	Readback as 0
Relay Output		

Modbus Register Table

Coils (0xxxx)

Register		Points	Description	Data Format	Attribute	Factory Default
DEC	HEX					
00000 : 00003	0000 : 0003	4	DO value	0: Off 1: On	R/W	-
00160 : 00163	00A0 : 00A3	4	Set the Power-on value of DO	0: Off 1: On	R/W	0
00192 : 00195	00C0 : 00C3	4	Set the trigger mode of DI counter	0: Counted at falling edge 1: Counted at rising edge	R/W	0
00263	0107	1	Clear latched DIO status	1: Clear	W	-
00264	0108	1	Enable/Disable the inverse operation of DI signal	0: Disable 1: Enable	R/W	0
00265	0109	1	Enable/Disable the inverse operation of DO signal	0: Disable 1: Enable	R/W	0
00268	010C	1	Set the AI data format	0: Hexadecimal format 1: Engineering unit	R/W	0
00512 : 00515	0200 : 0203	4	Clear the DI counter value	1: Clear	W	-

Discrete Inputs (1xxxx)

Register		Points	Description	Data Format	Attribute
DEC	HEX				
10032 : 10035	0020 : 0023	4	DI value	0: Off 1: On	R
10064 : 10067	0040 : 0043	4	Read "high latch" status of DI	0: Normal 1: Latched	R
10096 : 10099	0060 : 0063	4	Read "low latch" status of DI	0: Normal 1: Latched	R
10232 : 10235	00E8 : 00EB	4	Read the open or broken wire detection status of 4 mA ~ 20 mA of AO (*1)	0: Normal 1: Wire Opened	R

*1: Only the 4 ~ 20 mA of AO supports open or broken wire detection

Input Register (3xxxx)

Register		Points	No. Per Point	Description	Data Format	Attribute
DEC	HEX					
30128 : 30135	0080 : 0087	4	2	DI counter value Each 32-bit counter is calculated by formula: register_high x 65536 + register_low Example: Register_low=0x5678 Register_high=0x1234 32-bit value = 0x1234 x 65536 + 0x5678 = 0x12345678	0 to 4294967295	R

Holding Register (4xxxx)

Register		Points	No. Per Point	Description	Data Format	Attribute	Factory Value
DEC	HEX						
40032 : 40035	0020 : 0023	4	1	AO value	-	R/W	-
40192 : 40195	00C0 : 00C3	4	1	Set the Power-on value of AO	-	R/W	0
40288 : 40291	0120 : 0123	4	1	Set the slew rate of AO	0 to 15	R/W	0
40416 : 40419	01A0 : 01A3	4	1	Set the AO range * The jumper associated with an AO channel needs be set to voltage output or current output correctly to meet the AO range setting for the same channel.	0: 0~20 mA 1: 4 ~ 20 mA A 2: 0 ~ 10 V 3: ±10 V 4: 0 ~ 5 V 5: ±5 V	R/W	2
40480	01E0	1	1	Firmware version (low word)	0 to 255	R	-
40481	01E1	1	1	Firmware version (high word)	0 to 255	R	-
40482	01E2	1	1	Module name (low word), 0x0300	-	R	-
40483	01E3	1	1	Module name (high word), 0x5603	-	R	-

Analog Output Range

Type Code	Range	Data Format	Minimum	Maximum
00	0 ~ 20 mA	Engineering	0	+20000
		Hexadecimal	0000h	FFFFh
01	4 ~ 20 mA	Engineering	+4000	+20000
		Hexadecimal	0000h	FFFFh
02	0 ~ +10 V	Engineering	0	+10000
		Hexadecimal	0000h	FFFFh
03	-10 ~ +10 V	Engineering	-10000	+10000
		Hexadecimal	8000h	7FFFh
04	0 ~ +5 V	Engineering	0	+5000
		Hexadecimal	0000h	FFFFh
05	-5 ~ +5 V	Engineering	-5000	+5000
		Hexadecimal	8000h	7FFFh

Analog Output Slew Rate

Set Value	V/s	mA/s
0	Immediate	
1	0.0625	0.125
2	0.125	0.25
3	0.25	0.5
4	0.5	1.0
5	1.0	2.0
6	2.0	4.0
7	4.0	8.0

Set Value	V/s	mA/s
8	8.0	16.0
9	16.0	32.0
10	32.0	64.0
11	64.0	128.0
12	128.0	256.0
13	256.0	512.0
14	512.0	1024.0
15	1024.0	2048.0

XV306

I/O Specifications

Analog Input		
Channels	4	
Type	$\pm 1\text{ V}$, $\pm 2.5\text{ V}$, $\pm 5\text{ V}$, $\pm 10\text{ V}$ $\pm 20\text{ mA}$, $0\sim 20\text{ mA}$, $4\sim 20\text{ mA}$ (Jumper Selectable)	
Resolution	16-bit	
Sampling Rate	Normal Mode	10 Hz
	Fast Mode	200 Hz
Accuracy	Normal Mode	$\pm 0.1\%$
	Fast Mode	$\pm 0.5\%$
Input Impedance	20 M Ω	
Overvoltage Protection	+120 V _{DC}	
Individual Channel Configuration	Yes	
Digital Input/Counter		
Channels	4	
Type	Wet Contact	
Sink/Source (NPN/PNP)	Sink/Source	
On Voltage Level	+3.5 V _{DC} ~ +50 V _{DC}	
Off Voltage Level	+1 V _{DC} Max.	
Input Impedance	10 K Ω , 0.5W	
Counter	Channels	4
	Max. Count	4,294,967,285 (32-bit)
	Max. Input Frequency	50 Hz
	Min. Pulse Width	10 ms
Overvoltage Protection	+70 V _{DC}	
Relay Output		
Channels	4	
Type	Power Relay	
Form A Relay	Contact Rating	6 A @ 35 V _{DC} 6 A @ 240 V _{AC}
	Min. Contact Load	100 mA @ $\geq 12\text{ V}$
	Contact Material	Silver Cadmium Alloy
	Operate Time	5 ms (typical)
	Release Time	1 ms (typical)
	Mechanical Endurance	30 X 10 ⁶ ops.
	Electrical Endurance	1 X 10 ⁵ ops.
Power-on Value	Yes, Programmable	

Pin Assignment



Internal I/O Structure

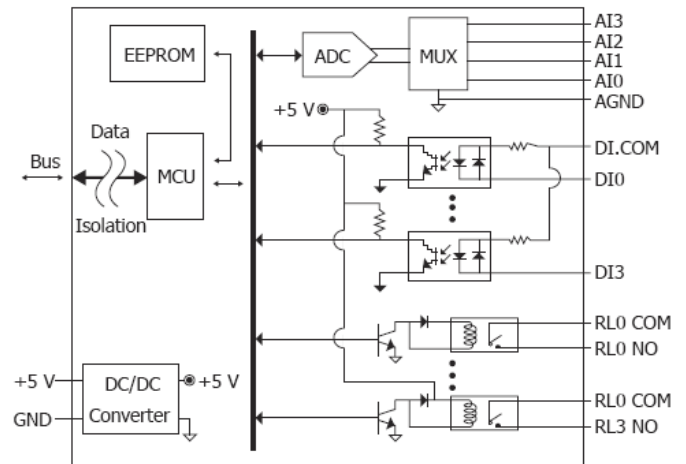

Wire Connections

Voltage Input

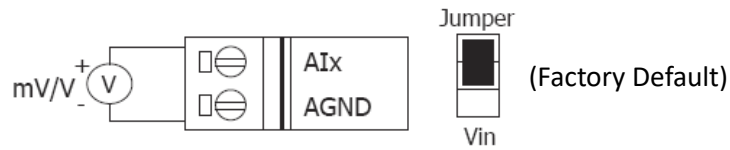

Current Input

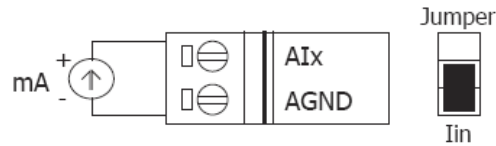

Digital Input/Counter	Readback as 1	Readback as 0
	+3.5 ~ +50 VDC	+1 VDC Max.
Wet Contact (Sink)	<p>The diagram shows a sink configuration for a wet contact. A switch is connected to the DIx terminal. The other end of the switch is connected to a positive voltage source (+) and a 10 KΩ pull-up resistor. The other end of the resistor is connected to the DI.COM terminal. The switch is shown in the closed position, indicating a '1' readback.</p>	<p>The diagram shows a sink configuration for a wet contact. A switch is connected to the DIx terminal. The other end of the switch is connected to a positive voltage source (+) and a 10 KΩ pull-up resistor. The other end of the resistor is connected to the DI.COM terminal. The switch is shown in the open position, indicating a '0' readback.</p>
	+3.5 ~ +50 VDC	+1 VDC Max.
Wet Contact (Source)	<p>The diagram shows a source configuration for a wet contact. A switch is connected to the DIx terminal. The other end of the switch is connected to a positive voltage source (+) and a 10 KΩ pull-up resistor. The other end of the resistor is connected to the DI.COM terminal. The switch is shown in the closed position, indicating a '1' readback.</p>	<p>The diagram shows a source configuration for a wet contact. A switch is connected to the DIx terminal. The other end of the switch is connected to a positive voltage source (+) and a 10 KΩ pull-up resistor. The other end of the resistor is connected to the DI.COM terminal. The switch is shown in the open position, indicating a '0' readback.</p>
Power Relay	Readback as 1	Readback as 0
Relay Output	<p>The diagram shows a relay output configuration. The relay coil is connected to the RLx COM terminal. The other end of the coil is connected to the RLx NO terminal. The load is connected between the AC/DC source and the RLx NO terminal. The relay is shown in the closed position, indicating a '1' readback.</p>	<p>The diagram shows a relay output configuration. The relay coil is connected to the RLx COM terminal. The other end of the coil is connected to the RLx NO terminal. The load is connected between the AC/DC source and the RLx NO terminal. The relay is shown in the open position, indicating a '0' readback.</p>

Modbus Register Table

Coils (0xxxx)

Register		Points	Description	Data Format	Attribute	Factory Default
DEC	HEX					
00000 : 00003	0000 : 0003	4	DO value	0: Off 1: On	R/W	-
00160 : 00163	00A0 : 00A3	4	Set the Power-on value of DO	0: Off 1: On	R/W	0
00192 : 00195	00C0 : 00C3	4	Set the trigger mode of DI counter	0: Counted at falling edge 1: Counted at rising edge	R/W	0
00263	0107	1	Clear latched DIO status	1: Clear	W	-
00264	0108	1	Enable/Disable the inverse operation of DI signal	0: Disable 1: Enable	R/W	0
00265	0109	1	Enable/Disable the inverse operation of DO signal	0: Disable 1: Enable	R/W	0
00268	010C	1	Set the AI data format	0: Hexadecimal format 1: Engineering unit	R/W	0
00270	010E	1	Set the AI sampling rate	0: Normal mode (10 Hz) 1: Fast mode (200 Hz)	R/W	0
00512 : 00515	0200 : 0203	4	Clear the DI counter value	1: Clear	W	-

Discrete Inputs (1xxxx)

Register		Points	Description	Data Format	Attribute
DEC	HEX				
10032 : 10035	0020 : 0023	4	DI value	0: Off 1: On	R
10064 : 10067	0040 : 0043	4	Read "high latch" status of DI	0: Normal 1: Latched	R
10096 : 10099	0060 : 0063	4	Read "low latch" status of DI	0: Normal 1: Latched	R
10224 : 10227	00E0 : 00E3	4	Read the open or broken wire detection status of 4 mA ~ 20 mA of AI (*1)	0: Normal 1: Wire Opened	R

*1: Only the 4 ~ 20 mA of AI supports open or broken wire detection

Input Register (3xxxx)

Register		Points	No. Per Point	Description	Data Format	Attribute
DEC	HEX					
30000 : 30003	0000 : 0003	4	1	AI value	-32768 to 32767 (0x0000 to 0xFFFF)	R
30128 : 30135	0080 : 0087	4	2	DI counter value Each 32-bit counter is calculated by formula: register_high x 65536 + register_low Example: Register_low=0x5678 Register_high=0x1234 32-bit value = 0x1234 x 65536 + 0x5678 = 0x12345678	0 to 4294967295	R

Holding Register (4xxxx)

Register		Points	No. Per Point	Description	Data Format	Attribute	Factory Value
DEC	HEX						
40256 : 40259	0100 : 0103	4	1	Set the AI range * The jumper associated with an AI channel needs be set to voltage input or current input correctly to meet the AI range setting for the same channel.	0x05: +/- 2.5 V 0x06: +/- 20 mA 0x08: +/- 10 V 0x09: +/- 5 V 0x0A: +/- 1 V 0x0D: +/-20 mA 0x1A: 0~20 mA 0x1D: 4 ~ 20 mA	R/W	0x08
40480	01E0	1	1	Firmware version (low word)	0 to 255	R	-
40481	01E1	1	1	Firmware version (high word)	0 to 255	R	-
40482	01E2	1	1	Module name (low word), 0x0600	-	R	-
40483	01E3	1	1	Module name (high word), 0x5603	-	R	-
40489	01E9	1	1	Enable/Disable the AI channel * Each bit corresponds to one channel. * Disable an unused AI channel can increase the sampling rate of the using channels. Sampling rage per channel = $\frac{\text{[Total sampling rate]}}{\text{[Enabled channel count]}}$	0x00 ~ 0xFF Bit N=0: Disable the channel N Bit N=1: Enable the channel N	R/W	0x0F

Analog Input Range

Type Code	Range	Data Format	Minimum	Maximum	Open Wire (Broken Wire)
05	+/- 2.5 V	Engineering	-25000	+25000	-
		Hexadecimal	8000h	7FFFh	
06	+/- 20 mA	Engineering	-20000	+20000	-
		Hexadecimal	8000h	7FFFh	
08	+/- 10 V	Engineering	-10000	+10000	-
		Hexadecimal	8000h	7FFFh	
09	+/- 5 V	Engineering	-5000	+5000	-
		Hexadecimal	8000h	7FFFh	
0A	+/- 1 V	Engineering	-10000	+10000	-
		Hexadecimal	8000h	7FFFh	
0D	+/- 20 mA	Engineering	-20000	+20000	-
		Hexadecimal	8000h	7FFFh	
1A	0 ~ 20 mA	Engineering	0	+20000	-
		Hexadecimal	0000h	FFFFh	
1D	4 ~ 20 mA (*2)	Engineering	+4000	+20000	0
		Hexadecimal	1999h	7FFFh	0000

*2: Only the 4 ~ 20 mA of AI supports open or broken wire detection.

XV307

I/O Specifications

Analog Output		
Channels	2	
Type	+0 V ~ +5 V, +0 V ~ +10 V, ±5 V, ±10 V 0~20 mA, 4~20 mA (Jumper Selectable)	
Resolution	12-bit	
Accuracy	±0.1%	
Voltage Output Capability	10 V @ 20 mA	
Current Load Resistance	500 Ω	
Power-on Value	Yes	
Individual Channel Configuration	Yes	
Digital Input/Counter		
Channels	4	
Type	Wet Contact	
Sink/Source (NPN/PNP)	Sink/Source	
On Voltage Level	+3.5 V _{DC} ~ +50 V _{DC}	
Off Voltage Level	+1 V _{DC} Max.	
Input Impedance	10 KΩ, 0.5W	
Counter	Channels	4
	Max. Count	4,294,967,285 (32-bit)
	Max. Input Frequency	50 Hz
	Min. Pulse Width	10 ms
Overvoltage Protection	+70 V _{DC}	
Relay Output		
Channels	4	
Type	Power Relay	
Form A Relay	Contact Rating	6 A @ 35 V _{DC} 6 A @ 240 V _{AC}
	Min. Contact Load	100 mA @ ≥ 12 V
	Contact Material	Silver Cadmium Alloy
	Operate Time	5 ms (typical)
	Release Time	1 ms (typical)
	Mechanical Endurance	30 X 10 ⁶ ops.
Electrical Endurance	1 X 10 ⁵ ops.	
Power-on Value	Yes, Programmable	

Pin Assignment



Internal I/O Structure

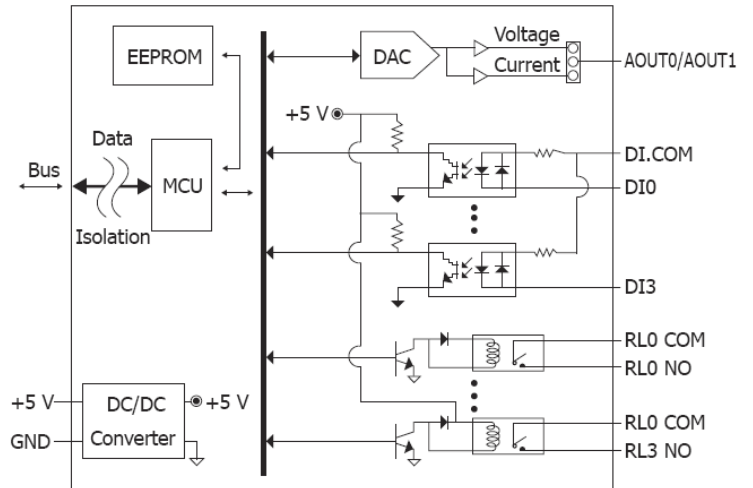

Wire Connections

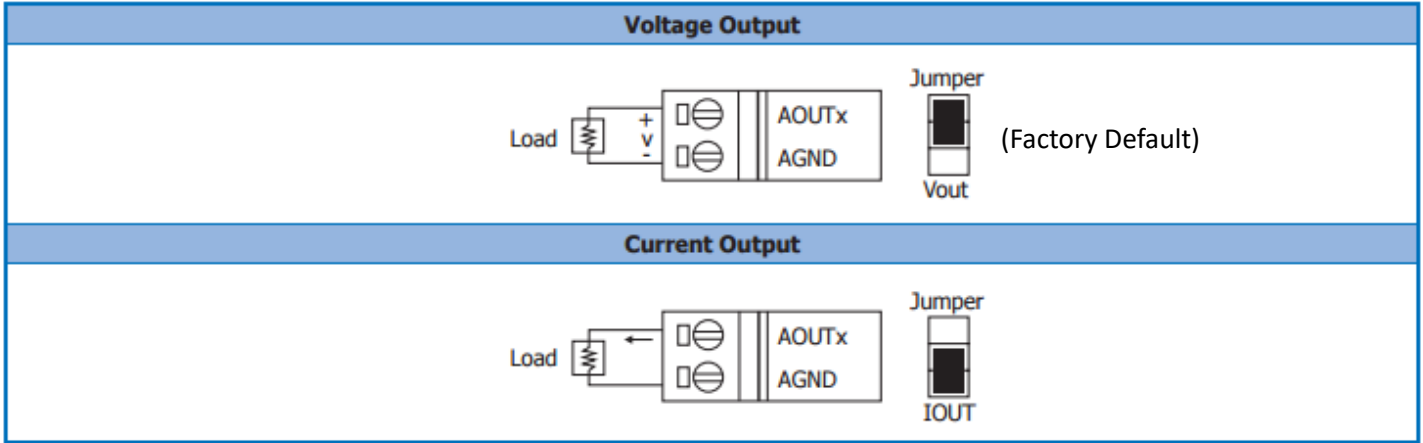

Digital Input/Counter	Readback as 1 +3.5 ~ +50 VDC	Readback as 0 +1 VDC Max.
Wet Contact (Sink)		
Wet Contact (Source)		
Power Relay	Readback as 1	Readback as 0
Relay Output		

Modbus Register Table

Coils (0xxxx)

Register		Points	Description	Data Format	Attribute	Factory Default
DEC	HEX					
00000 : 00003	0000 : 0003	4	DO value	0: Off 1: On	R/W	-
00160 : 00163	00A0 : 00A3	4	Set the Power-on value of DO	0: Off 1: On	R/W	0
00192 : 00195	00C0 : 00C3	4	Set the trigger mode of DI counter	0: Counted at falling edge 1: Counted at rising edge	R/W	0
00263	0107	1	Clear latched DI status	1: Clear	W	-
00264	0108	1	Enable/Disable the inverse operation of DI signal	0: Disable 1: Enable	R/W	0
00265	0109	1	Enable/Disable the inverse operation of DO signal	0: Disable 1: Enable	R/W	0
00268	010C	1	Set the AO data format	0: Hexadecimal format 1: Engineering unit	R/W	0
00512 : 00515	0200 : 0203	4	Clear the DI counter value	1: Clear	W	-

Discrete Inputs (1xxxx)

Register		Points	Description	Data Format	Attribute
DEC	HEX				
10032 : 10035	0020 : 0023	4	DI value	0: Off 1: On	R
10064 : 10067	0040 : 0043	4	Read DI "high latch" status	0: Normal 1: Latched	R
10096 : 10099	0060 : 0063	4	Read DI "low latch" status	0: Normal 1: Latched	R
10232 : 10233	00E8 : 00E9	2	Read the open or broken wire detection status of 4 ~ 20 mA of AO (*1)	0: Normal 1: Wire Opened	R

*1: Only the 4 ~ 20 mA of AO supports open or broken wire detection

Input Register (3xxxx)

Register		Points	No. Per Point	Description	Data Format	Attribute
DEC	HEX					
30128 : 30135	0080 : 0087	4	2	DI counter value Each 32-bit counter is calculated by formula: register_high x 65536 + register_low Example: Register_low=0x5678 Register_high=0x1234 32-bit value = 0x1234 x 65536 + 0x5678 = 0x12345678	0 to 4294967295	R

Holding Register (4xxxx)

Register		Points	No. Per Point	Description	Data Format	Attribute	Factory Value
DEC	HEX						
40032 : 40033	0020 : 0021	2	1	AO value	-	R/W	-
40192 : 40193	00C0 : 00C1	2	1	Set the Power-on value of AO	-	R/W	0
40288 : 40289	0120 : 0121	2	1	Set the slew rate of AO	0 to 15	R/W	0
40416 : 40417	01A0 : 01A1	2	1	Set the AO range * The jumper associated with an AO channel needs be set to voltage output or current output correctly to meet the AO range setting for the same channel.	0: 0~20 mA 1: 4~20 mA 2: 0 ~ 10 V 3: +/- 10 V 4. 0 ~ 5 V 5. +/- 5 V	R/W	0x02
40480	01E0	1	1	Firmware version (low word)	0 to 255	R	-
40481	01E1	1	1	Firmware version (high word)	0 to 255	R	-
40482	01E2	1	1	Module name (low word), 0x0700	-	R	-
40483	01E3	1	1	Module name (high word), 0x5603	-	R	-

Analog Output Range

Type Code	Range	Data Format	Minimum	Maximum
00	0 ~ 20 mA	Engineering	0	+20000
		Hexadecimal	0000h	FFFFh
01	4 ~ 20 mA	Engineering	+4000	+20000
		Hexadecimal	0000h	FFFFh
02	+0 V ~ +10 V	Engineering	0	+10000
		Hexadecimal	0000h	FFFFh
03	+/- 10 V	Engineering	-10000	+10000
		Hexadecimal	8000h	7FFFh
04	+0 V ~ +5 V	Engineering	0	+5000
		Hexadecimal	0000h	FFFFh
05	+/- 5 V	Engineering	-5000	+5000
		Hexadecimal	8000h	7FFFh

Analog Output Slew Rate

Set Value	V/s	mA/s
0	Immediate	
1	0.0625	0.125
2	0.125	0.25
3	0.25	0.5
4	0.5	1.0
5	1.0	2.0
6	2.0	4.0
7	4.0	8.0

Set Value	V/s	mA/s
8	8.0	16.0
9	16.0	32.0
10	32.0	64.0
11	64.0	128.0
12	128.0	256.0
13	256.0	512.0
14	512.0	1024.0
15	1024.0	2048.0

XV308

I/O Specifications

Analog Input			
Channels	8		
Type	±1 V, ±2.5 V, ±5 V, ±10 V ±20 mA, 0~20 mA, 4~20 mA (Jumper Selectable)		
Resolution	16-bit		
Sampling Rate	Normal Mode	10 Hz	
	Fast Mode	200 Hz	
Accuracy	Normal Mode	±0.1%	
	Fast Mode	±0.5%	
Input Impedance	20 MΩ		
Overvoltage Protection	+120 V _{DC}		
Individual Channel Configuration	Yes		
Universal Digital Input/Output			
Channels	Digital Input and Digital Output=8 (By Wire Connection)		
Digital Input	Wet Contact	On Voltage Level	+1 V _{DC} Max.
		Off Voltage Level	+4 V _{DC} ~ +30 V _{DC}
	Dry Contact	On Voltage Level	Close to GND
		Off Voltage Level	Open
	Counters	Max. Count	4,294,967,285 (32-bit)
		Max. Input Frequency	50 Hz
		Min. Pulse Width	10 ms
Overvoltage Protection	+60 V _{DC}		
Digital Output	Output Type	Sink	
	Max. Load Current	700 mA	
	Load Voltage	3.5 ~ 50 V _{DC}	
	Overvoltage Protection	+60 V _{DC}	
	Overload Protection	Yes	
	Short Circuit Protection	Yes	
	Power-on Value	Yes, Programmable	

Pin Assignment

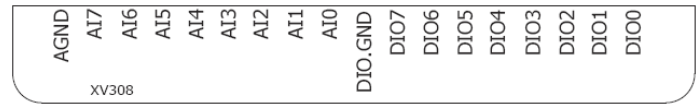

Internal I/O Structure

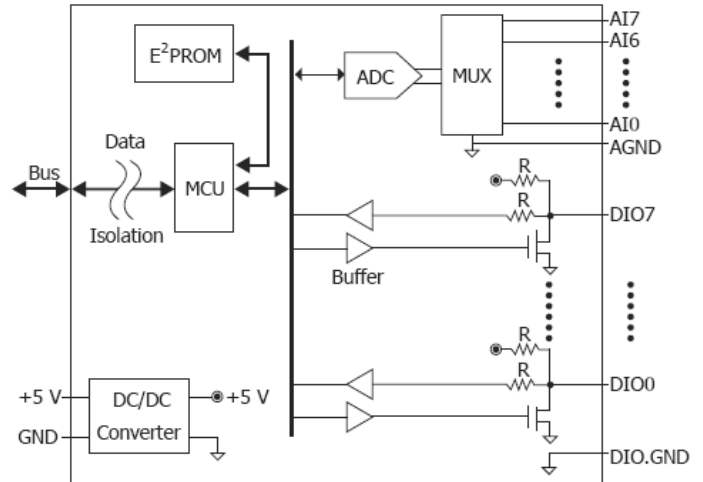

The 8 Universal DI/DO channels on the XV308 can be individually selected to be DI channels or DO channels via wire connections.

When one is wired as a DI channel, the registers for DO value (00000 ~ 00007) and Power on value (00160 ~ 00167) associated with the channel need be set as 0.

Wire Connections

Voltage Input (Single-ended Mode)

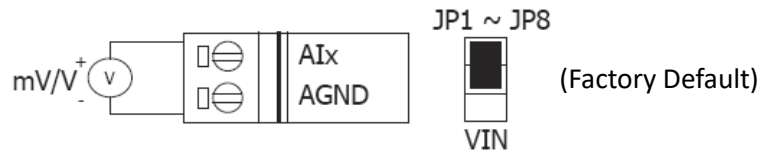

Current Input (Single-ended Mode)



Digital Input/ Counter	ON State Readback as 1	OFF State Readback as 0
	+1 Vdc Max.	+4 ~ 30 Vdc
Wet Contact (Sink)		
Dry Contact (Source)		
Digital Output	ON State Readback as 1	OFF State Readback as 0
Open Collector (Sink)		

Modbus Register Table

Coils (0xxxx)

Register		Points	Description	Data Format	Attribute	Factory Default
DEC	HEX					
00000 : 00007	0000 : 0007	8	DO value	0: Off 1: On	R/W	-
00160 : 00167	00A0 : 00A7	8	Set the Power-on value of DO	0: Off 1: On	R/W	0
00192 : 00199	00C0 : 00C7	8	Set the trigger mode of DI counter	0: Counted at falling edge 1: Counted at rising edge	R/W	0
00263	0107	1	Clear latched DI status	1: Clear	W	-
00264	0108	1	Enable/Disable the inverse operation of DI signal	0: Disable 1: Enable	R/W	0
00265	0109	1	Enable/Disable the inverse operation of DO signal	0: Disable 1: Enable	R/W	0
00268	010C	1	Set the AI data format	0: Hexadecimal format 1: Engineering unit	R/W	0
00270	010E	1	Set the AI sampling rate	0: Normal mode (10 Hz) 1: Fast mode (200 Hz)	R/W	0
00512 : 00519	0200 : 0207	8	Clear the DI counter value	1: Clear	W	-

Discrete Inputs (1xxxx)

Register		Points	Description	Data Format	Attribute
DEC	HEX				
10032 : 10039	0020 : 0027	8	DI value To use a channel as a DI, the corresponding DO value and the power-on value need be set to 0.	0: Off 1: On	R
10064 : 10071	0040 : 0047	8	Read DI "high latch" status	0: Normal 1: Latched	R
10096 : 10103	0060 : 0067	8	Read DI "low latch" status	0: Normal 1: Latched	R
10224 : 00231	00E0 : 00E7	8	Read the open or broken wire detection status of 4 mA ~ 20 mA of AI (*1)	0: Normal 1: Wire Opened	R

*1: Only the 4 ~ 20 mA of AI supports open or broken wire detection

Input Register (3xxxx)

Register		Points	No. Per Point	Description	Data Format	Attribute
DEC	HEX					
30000 : 30007	0000 : 0007	8	1	AI value	-32768 to 32767 (0x0000 to 0xFFFF)	R
30128 : 30143	0080 : 008F	8	2	DI counter value Each 32-bit counter is calculated by formula: register_high x 65536 + register_low Example: Register_low=0x5678 Register_high=0x1234 32-bit value = 0x1234 x 65536 + 0x5678 = 0x12345678	0 to 4294967295	R

Holding Register (4xxxx)

Register		Points	No. Per Point	Description	Data Format	Attribute	Factory Value
DEC	HEX						
40256 : 40263	0100 : 0107	8	1	Set the AI range * The jumper associated with an AI channel needs be set to voltage input or current input correctly to meet the AI range setting for the same channel.	0x05: +/- 2.5 V 0x06: +/- 20 mA 0x08: +/- 10 V 0x09: +/- 5 V 0x0A: +/- 1 V 0x0D: +/-20 mA 0x1A: 0~20 mA 0x1D: 4 ~ 20 mA	R/W	0x08
40480	01E0	1	1	Firmware version (low word)	0 to 255	R	-
40481	01E1	1	1	Firmware version (high word)	0 to 255	R	-
40482	01E2	1	1	Module name (low word), 0x0800	-	R	-
40483	01E3	1	1	Module name (high word), 0x5603	-	R	-
40489	01E9	1	1	Enable/Disable the AI channel * Each bit corresponds to one channel. * Disable an unused AI channel can increase the sampling rate of the using channels. Sampling rage per channel = $\frac{[\text{Total sampling rate}]}{[\text{Enabled channel count}]}$	0x00 ~ 0xFF Bit N=0: Disable the channel N Bit N=1: Enable the channel N	R/W	0xFF

Analog Input Range

Type Code	Range	Data Format	Minimum	Maximum	Open Wire (Broken Wire)
05	+/- 2.5 V	Engineering	-25000	+25000	-
		Hexadecimal	8000h	7FFFh	
06	+/- 20 mA	Engineering	-20000	+20000	-
		Hexadecimal	8000h	7FFFh	
08	+/- 10 V	Engineering	-10000	+10000	-
		Hexadecimal	8000h	7FFFh	
09	+/- 5 V	Engineering	-5000	+5000	-
		Hexadecimal	8000h	7FFFh	
0A	+/- 1 V	Engineering	-10000	+10000	-
		Hexadecimal	8000h	7FFFh	
0D	+/- 20 mA	Engineering	-20000	+20000	-
		Hexadecimal	8000h	7FFFh	
1A	0 ~ 20 mA	Engineering	0	+20000	-
		Hexadecimal	0000h	FFFFh	
1D	4 ~ 20 mA (*2)	Engineering	+4000	+20000	0
		Hexadecimal	1999h	7FFFh	0000

*2: Only the 4 ~ 20 mA of AI supports open or broken wire detection.

XV310

I/O Specifications

Analog Input		
Channels	4	
Type	±1 V, ±2.5 V, ±5 V, ±10 V ±20 mA, 0~20 mA, 4~20 mA (Jumper Selectable)	
Resolution	16-bit	
Sampling Rate	Normal Mode	10 Hz
	Fast Mode	200 Hz
Accuracy	Normal Mode	±0.1%
	Fast Mode	±0.5%
Overvoltage Protection	+120 V _{DC}	
Individual Channel Configuration	Yes	
Analog Output		
Channels	2	
Type	0 V ~ +5 V, 0 V ~ +10 V, ±5 V, ±10 V, 0~20 mA, 4~20 mA (Jumper Selectable)	
Resolution	12-bit	
Accuracy	±0.1%	
Voltage Output Capability	10 V @ 20 mA	
Current Load Resistance	500 Ω	
Power-on Value	Yes	
Digital Input		
Channels	4	
Type	Dry Contact	
Sink/Source (NPN/PNP)	Source	
On Voltage Level	Close to GND	
Off Voltage Level	Open	
Input Impedance	-	
Counters	Max. Count	4,294,967,285 (32-bit)
	Max. Input Frequency	50 Hz
	Min. Pulse Width	10 ms
Overvoltage Protection	+60 V _{DC}	
Digital Output		
Channels	4	
Type	Source	
Max. Load Current	650 mA/channel	
Load Voltage	+10 V _{DC} ~ +40 V _{DC}	
Overvoltage Protection	+47 V _{DC}	
Overload Protection	Yes	
Short-circuit Protection	Yes	
Power-on Value	Yes, Programmable	

Pin Assignment

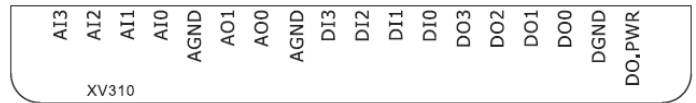

Internal I/O Structure

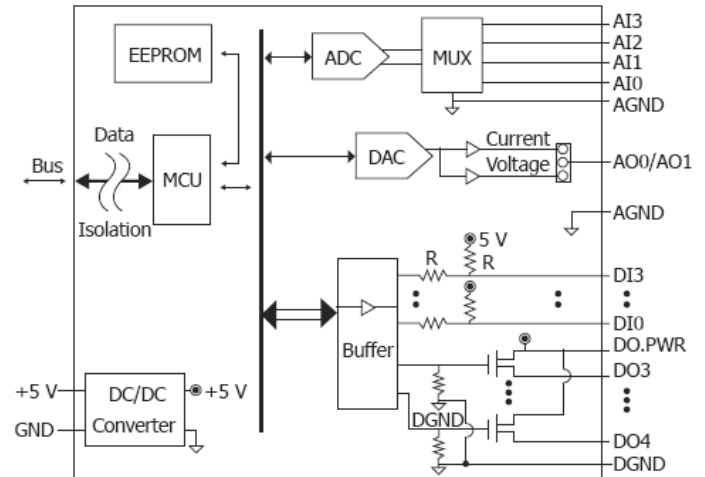

Wire Connections

Voltage Input		
		Jumper (Factory Default)
Current Input		
		Jumper Iin
Voltage Output		
		Jumper (Factory Default)
Current Output		
		Jumper IOUT
Digital Input/ Counter	ON State Readback as 1	OFF State Readback as 0
Dry Contact (Source)		
Digital Output	ON State Readback as 1	OFF State Readback as 0
Open Drain (Source)		

Modbus Register Table

Coils (0xxxx)

Register		Points	Description	Data Format	Attribute	Factory Default
DEC	HEX					
00000 : 00003	0000 : 0003	4	DO value	0: Off 1: On	R/W	-
00160 : 00163	00A0 : 00A3	4	Set the Power-on value of DO	0: Off 1: On	R/W	0
00192 : 00195	00C0 : 00C3	4	Set the trigger mode of DI counter	0: Counted at falling edge 1: Counted at rising edge	R/W	0
00263	0107	1	Clear latched DI status	1: Clear	W	-
00264	0108	1	Enable/Disable the inverse operation of DI signal	0: Disable 1: Enable	R/W	0
00265	0109	1	Enable/Disable the inverse operation of DO signal	0: Disable 1: Enable	R/W	0
00268	010C	1	Set the AI/AO data format	0: Hexadecimal format 1: Engineering unit	R/W	0
00270	010E	1	Set the AI sampling rate	0: Normal mode (10 Hz) 1: Fast mode (200 Hz)	R/W	0
00512 : 00515	0200 : 0203	4	Clear the DI counter value	1: Clear	W	-

Discrete Inputs (1xxxx)

Register		Points	Description	Data Format	Attribute
DEC	HEX				
10032 : 10035	0020 : 0023	4	DI value	0: Off 1: On	R
10064 : 10067	0040 : 0043	4	Read DI "high latch" status	0: Normal 1: Latched	R
10096 : 10099	0060 : 0063	4	Read DI "low latch" status	0: Normal 1: Latched	R
10224 : 10227	00E0 : 00E3	4	Read the open or broken wire detection status of 4 mA ~ 20 mA of AI (*1)	0: Normal 1: Wire Opened	R
10232 : 10233	00E8 : 00E9	2	Read the open or broken wire detection status of 4 ~ 20 mA of AO (*2)	0: Normal 1: Wire Opened	R

*1, *2: Only the 4 ~ 20 mA of AI and AO support open or broken wire detection

Input Register (3xxxx)

Register		Points	No. Per Point	Description	Data Format	Attribute
DEC	HEX					
30000 : 30003	0000 : 0003	4	1	AI value	-32768 to 32767 (0x0000 to 0xFFFF)	R
30128 : 30135	0080 : 0087	4	2	DI counter value Each 32-bit counter is calculated by formula: register_high x 65536 + register_low Example: Register_low=0x5678 Register_high=0x1234 32-bit value = 0x1234 x 65536 + 0x5678 = 0x12345678	0 to 4294967295	R

Holding Register (4xxxx)

Register		Points	No. Per Point	Description	Data Format	Attribute	Factory Value
DEC	HEX						
40032 : 40033	0020 : 0021	2	1	AO value	-	R/W	-
40192 : 40193	00C0 : 00C1	2	1	Set the Power-on value of AO	-	R/W	0
40256 : 40259	0100 : 0103	4	1	Set the AI range * The jumper associated with an AI channel needs be set to voltage input or current input correctly to meet the AI range setting for the same channel.	0x05: +/- 2.5 V 0x06: +/- 20 mA 0x08: +/- 10 V 0x09: +/- 5 V 0x0A: +/- 1 V 0x0D: +/-20 mA 0x1A: 0~20 mA 0x1D: 4 ~ 20 mA	R/W	0x08
40288 : 40289	0120 : 0121	2	1	Set the slew rate of AO	0 to 15	R/W	0
40416 : 40417	01A0 : 01A1	2	1	Set the AO range * The jumper associated with an AO channel needs be set to voltage output or current output correctly to meet the AO range setting for the same channel.	0: 0~20 mA 1: 4~20 mA 2: 0 ~ 10 V 3: +/- 10 V 4. 0 ~ 5 V 5. +/- 5 V	R/W	0x02
40480	01E0	1	1	Firmware version (low word)	0 to 255	R	-
40481	01E1	1	1	Firmware version (high word)	0 to 255	R	-
40482	01E2	1	1	Module name (low word), 0x1000	-	R	-
40483	01E3	1	1	Module name (high word), 0x5603	-	R	-
40489	01E9	1	1	Enable/Disable the AI channel * Each bit corresponds to one channel. * Disable an unused AI channel can increase the sampling rate of the using channels.	0x00 ~ 0x0F Bit N=0: Disable the channel N	R/W	0x0F

				Sampling rage per channel = $\frac{[\text{Total sampling rate}]}{[\text{Enabled channel count}]}$	Bit N=1: Enable the channel N		
--	--	--	--	--	-------------------------------	--	--

Analog Input Range

Type Code	Range	Data Format	Minimum	Maximum	Open Wire (Broken Wire)
05	+/- 2.5 V	Engineering	-25000	+25000	-
		Hexadecimal	8000h	7FFFh	
06	+/- 20 mA	Engineering	-20000	+20000	-
		Hexadecimal	8000h	7FFFh	
08	+/- 10 V	Engineering	-10000	+10000	-
		Hexadecimal	8000h	7FFFh	
09	+/- 5 V	Engineering	-5000	+5000	-
		Hexadecimal	8000h	7FFFh	
0A	+/- 1 V	Engineering	-10000	+10000	-
		Hexadecimal	8000h	7FFFh	
0D	+/- 20 mA	Engineering	-20000	+20000	-
		Hexadecimal	8000h	7FFFh	
1A	0 ~ 20 mA	Engineering	0	+20000	-
		Hexadecimal	0000h	FFFFh	
1D	4 ~ 20 mA (*3)	Engineering	+4000	+20000	0
		Hexadecimal	1999h	7FFFh	0000

*3: Only the 4 ~ 20 mA of AI supports open or broken wire detection.

Analog Output Range

Type Code	Range	Data Format	Minimum	Maximum
00	0 ~ 20 mA	Engineering	0	+20000
		Hexadecimal	0000h	FFFFh
01	4 ~ 20 mA	Engineering	+4000	+20000
		Hexadecimal	0000h	FFFFh
02	+0 V ~ +10 V	Engineering	0	+10000
		Hexadecimal	0000h	FFFFh
03	+/- 10 V	Engineering	-10000	+10000
		Hexadecimal	8000h	7FFFh
04	+0 V ~ +5 V	Engineering	0	+5000
		Hexadecimal	0000h	FFFFh
05	+/- 5 V	Engineering	-5000	+5000
		Hexadecimal	8000h	7FFFh

Analog Output Slew Rate

Set Value	V/s	mA/s
0	Immediate	
1	0.0625	0.125
2	0.125	0.25
3	0.25	0.5
4	0.5	1.0
5	1.0	2.0
6	2.0	4.0
7	4.0	8.0

Set Value	V/s	mA/s
8	8.0	16.0
9	16.0	32.0
10	32.0	64.0
11	64.0	128.0
12	128.0	256.0
13	256.0	512.0
14	512.0	1024.0
15	1024.0	2048.0

XV315

I/O Specifications

Analog Input		
Channels	3	
Type	RTD	
Sensor Type	Pt100, Pt1000, Ni120, Cu50, Cu100, Cu1000	
Resolution	16-bit	
Accuracy	±0.1% of FSR	
Sampling Rate	10 Hz (Total)	
Overvoltage Protection	+120 V _{DC}	
Individual Channel Configuration	Yes	
Open Wire Detection	Yes	
3-wire RTD Lead Resistance Elimination	Yes	
Analog Output		
Channels	3	
Type	0 V ~ +10 V, 0 ~ +20 mA, +4 ~ +20 mA	
Resolution	12-bit	
Accuracy	±0.2%	
Voltage Output Capability	10 V @ 10 mA	
Current Load Resistance	500 Ω	
Power-on Value	Yes, Programmable	
Digital Input		
Channels	4	
Type	Wet Contact	
Sink/Source (NPN/PNP)	Sink/Source (NPN/PNP)	
On Voltage Level	+3.5 ~ +30 VDC	
Off Voltage Level	+1 VDC Max.	
Input Impedance	3 kΩ, 0.5 W	
Counters	Max. Count	4,294,967,285 (32-bit)
	Max. Input Frequency	3k Hz

Pin Assignment

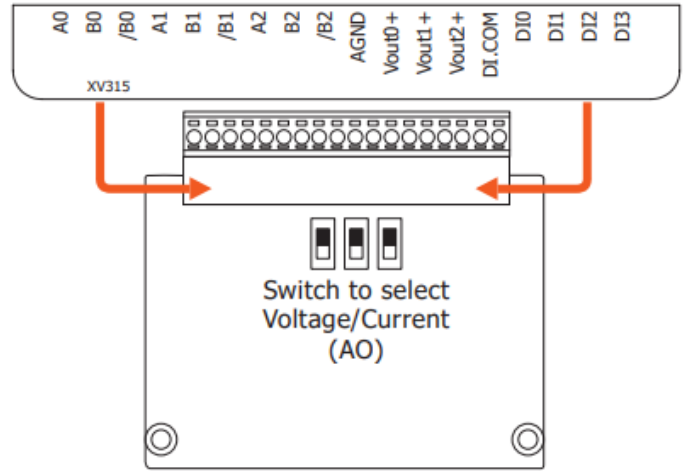

Internal I/O Structure

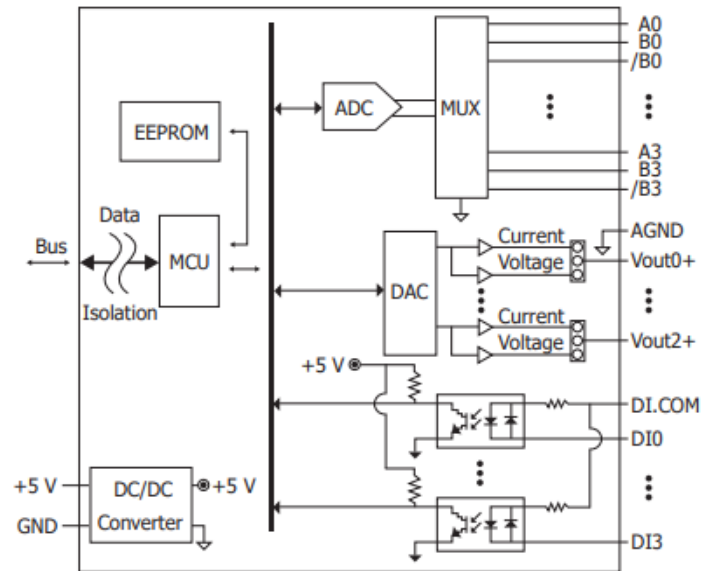

Wire Connections

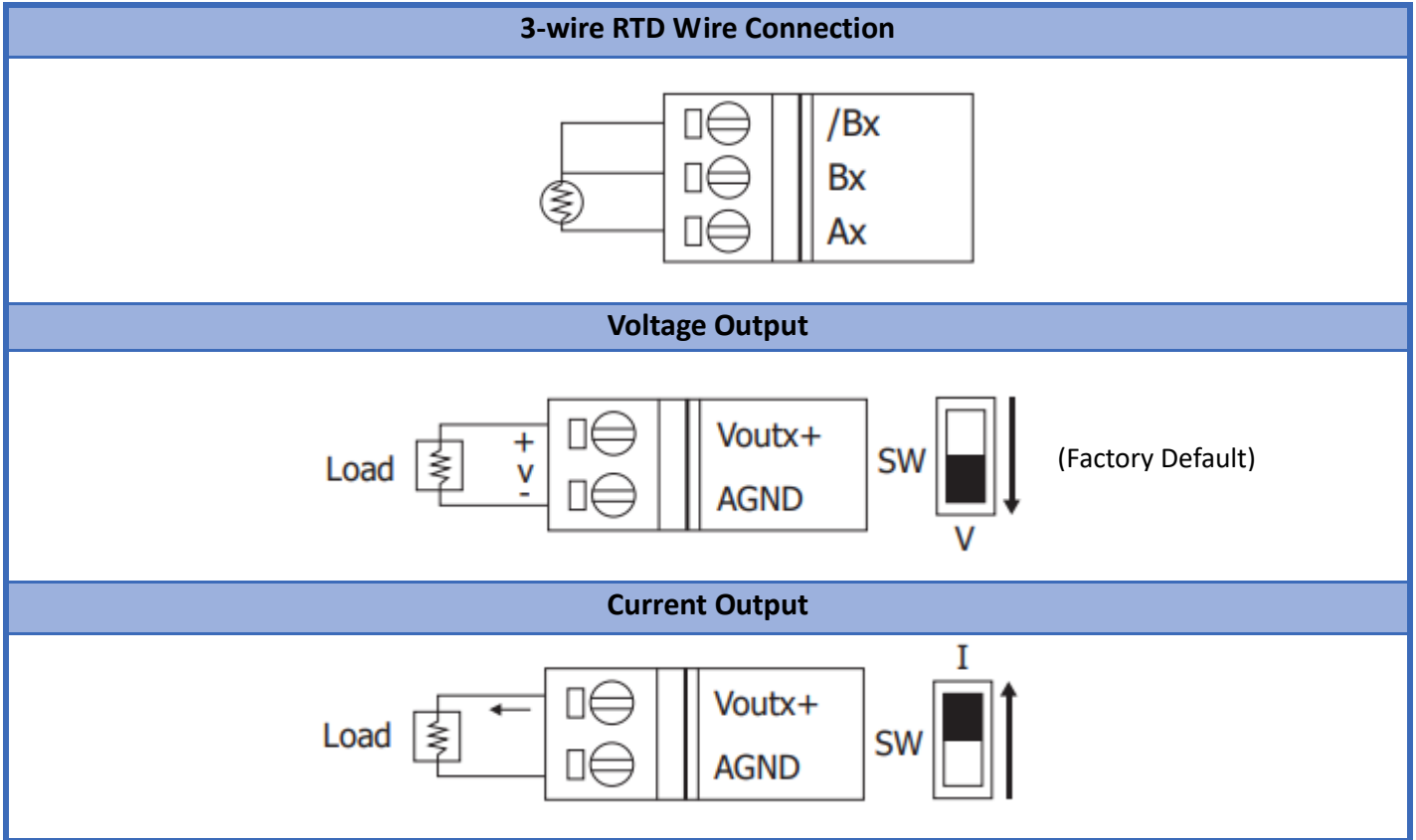

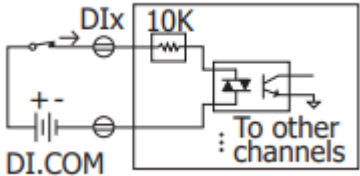
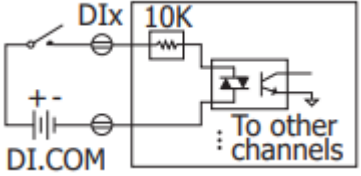
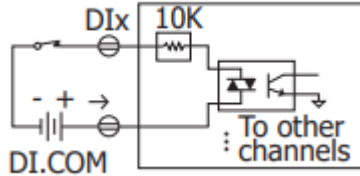
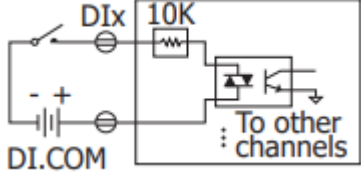
Digital Input	Readback as 1	Readback as 0
	+3.5 ~ +30 VDC	+1 VDC Max.
Wet Contact (Sink)		
	+3.5 ~ +30 VDC	+1 VDC Max.
Wet Contact (Source)		

Modbus Register Table

Coils (0xxxx)

Register		Points	Description	Data Format	Attribute	Factory Default
DEC	HEX					
00192 : 00195	00C0 : 00C3	4	Set the trigger mode of DI counter	0: Counted at falling edge 1: Counted at rising edge	R/W	0
00258	0102	1	Filter setting	0: 60 Hz rejection 1: 50 Hz rejection	R/W	0
00263	0107	1	Clear latched DI status	1: Clear	W	-
00264	0108	1	Enable/Disable the inverse operation of DI signal	0: Disable 1: Enable	R/W	0
00268	010C	1	Set the AI/AO data format	0: Hexadecimal format 1: Engineering unit	R/W	0
00271	010F	1	Load factory calibration parameters for AI and AO channels	1: Load	R/W	0
00512 : 00515	0200 : 0203	4	Clear the DI counter value	1: Clear	W	-

Discrete Inputs (1xxxx)

Register		Points	Description	Data Format	Attribute
DEC	HEX				
10032 : 10035	0020 : 0023	4	DI value	0: Off 1: On	R
10064 : 10067	0040 : 0043	4	Read DI "high latch" status	0: Normal 1: Latched	R
10096 : 10099	0060 : 0063	4	Read DI "low latch" status	0: Normal 1: Latched	R
10224 : 10226	00E0 : 00E2	3	Read the over/under range status of AI	0: Normal 1: Over or under range	R
10232 : 10234	00E8 : 00EA	3	Read the open or broken wire detection status of 4 ~ 20 mA of AO (*1)	0: Normal 1: Wire opened	R

*1: Only the 4 ~ 20 mA of AO support open or broken wire detection

Input Register (3xxxx)

Register		Points	No. Per Point	Description	Data Format	Attribute
DEC	HEX					
30000 : 30002	0000 : 0002	3	1	AI temperature value Read the temperature in engineering format or hexadecimal format	-32768 to 32767 (0x0000 to 0xFFFF)	R
30128 : 30135	0080 : 0087	4	2	DI counter value Each 32-bit counter is calculated by formula: register_high x 65536 + register_low Example: Register_low=0x5678 Register_high=0x1234 32-bit value = 0x1234 x 65536 + 0x5678 = 0x12345678	0 to 4294967295	R
30640 : 30645	0280 : 0285	3	2	AI temperature value Each temperature value is floating point in IEEE 754 format, occupying two consecutive registers.	Depends on sensor measurement range	R
30864 : 30869	0360 : 0365	3	2	AI resistance This value is floating point in IEEE 754 format, occupying two consecutive registers .It is in 0.1 ohms for type code 2A and 2D and 0.01 ohms for other types.		R

Holding Register (4xxxx)

Register		Points	No. Per Point	Description	Data Format	Attribute	Factory Value
DEC	HEX						
40032 : 40034	0020 : 0022	3	1	AO value Refer to the Analog Output Range table below	-	R/W	-
40192 : 40194	00C0 : 00C2	3	1	Set the Power-on value of AO	-	R/W	0
40256 : 40258	0100 : 0102	3	1	Set the type code of AI Refer to the RTD Input Type table below.	20h to 85h	R/W	0x20
40288 : 40290	0120 : 0122	3	1	Set the slew rate of AO	0 to 15	R/W	0
40320 : 40322	0140 : 0142	3	1	Set the offset of AI in 0.01 °C	-	R/W	0
40384 : 40386	0180 : 0182	3	1	Set the resistance offset in 0.01 ohm	-	R/W	0
40416 : 40418	01A0 : 01A2	3	1	Set the AO range * The jumper associated with an AO channel needs be set to voltage output or current output correctly to meet the AO range setting for the same channel.	0: 0~20 mA 1: 4~20 mA 2: 0 ~ 10 V	R/W	0x02
40480	01E0	1	1	Firmware version (low word)	0 to 255	R	-
40481	01E1	1	1	Firmware version (high word)	0 to 255	R	-

40482	01E2	1	1	Module name (low word), 0x1500	-	R	-
40483	01E3	1	1	Module name (high word), 0x5603	-	R	-
40489	01E9	1	1	<p>Enable/Disable the AI channel</p> <p>* Each bit corresponds to one channel.</p> <p>* Disable an unused AI channel can increase the sampling rate of the using channels.</p> <p>Sampling rage per channel =</p> $\frac{[\text{Total sampling rate}]}{[\text{Enabled channel count}]}$	0x00 ~ 0x0F	R/W	0x0F

RTD Input Type

Type Code	Range	Data Format	Minimum	Maximum
20	Pt 100, $\alpha= 0.00385$	Engineering	-10000	+10000
		Hexadecimal	8000h	7FFFh
21	Pt 100, $\alpha= 0.00385$	Engineering	0	+10000
		Hexadecimal	0000h	7FFFh
22	Pt 100, $\alpha= 0.00385$	Engineering	0	+20000
		Hexadecimal	0000h	7FFFh
23	Pt 100, $\alpha= 0.00385$	Engineering	0	+6000
		Hexadecimal	0000h	7FFFh
24	Pt 100, $\alpha= 0.003916$	Engineering	-10000	+10000
		Hexadecimal	8000h	7FFFh
25	Pt 100, $\alpha= 0.003916$	Engineering	0	+10000
		Hexadecimal	0000h	7FFFh
26	Pt 100, $\alpha= 0.003916$	Engineering	0	+20000
		Hexadecimal	0000h	7FFFh
27	Pt 100, $\alpha= 0.003916$	Engineering	0	+6000
		Hexadecimal	0000h	7FFFh
28	Ni 120	Engineering	-8000	+10000
		Hexadecimal	999Ah	7FFFh
29	Ni 120	Engineering	0	+10000
		Hexadecimal	0000h	7FFFh
2A	Pt 1000, $\alpha= 0.00385$	Engineering	-2000	+6000
		Hexadecimal	D556h	7FFFh
2B	Cu 100, $\alpha= 0.00421$	Engineering	-2000	+15000
		Hexadecimal	EEEFh	7FFFh
2C	Cu 100, $\alpha= 0.00427$	Engineering	0	+20000
		Hexadecimal	0000h	7FFFh
2D	Cu 1000, $\alpha= 0.00421$	Engineering	-2000	+15000
		Hexadecimal	EEEFh	7FFFh
2E	Pt 100, $\alpha= 0.00385$	Engineering	-20000	+20000
		Hexadecimal	8000h	7FFFh

RTD Input Type

Type Code	Range	Data Format	Minimum	Maximum
2F	Pt 100, $\alpha = 0.003916$	Engineering	-20000	+20000
		Hexadecimal	8000h	7FFFh
80	Pt 100, $\alpha = 0.00385$	Engineering	-2000	+6000
		Hexadecimal	D556h	7FFFh
81	Pt 100, $\alpha = 0.003916$	Engineering	-2000	+6000
		Hexadecimal	D556h	7FFFh
82	Cu 50	Engineering	-5000	+15000
		Hexadecimal	D556h	7FFFh
83	Ni 100	Engineering	-6000	+18000
		Hexadecimal	D556h	7FFFh
84	Ni 120	Engineering	-8000	+15000
		Hexadecimal	BBBCh	7FFFh
85	Cu 100, $\alpha = 0.00428$	Engineering	0	+15000
		Hexadecimal	0000h	7FFFh

RTD Over Range/Under Range Reading

Over Range	Under Range
7FFFh	08000h

Analog Output Range

Type Code	Range	Data Format	Minimum	Maximum
00	0 ~ 20 mA	Engineering	0	+20000
		Hexadecimal	0000h	FFFFh
01	4 ~ 20 mA	Engineering	+4000	+20000
		Hexadecimal	0000h	FFFFh
02	+0 V ~ +10 V	Engineering	0	+10000
		Hexadecimal	0000h	FFFFh

Analog Output Slew Rate

Set Value	V/s	mA/s	Set Value	V/s	mA/s
0	Immediate		8	8.0	16.0
1	0.0625	0.125	9	16.0	32.0
2	0.125	0.25	10	32.0	64.0
3	0.25	0.5	11	64.0	128.0
4	0.5	1.0	12	128.0	256.0
5	1.0	2.0	13	256.0	512.0
6	2.0	4.0	14	512.0	1024.0
7	4.0	8.0	15	1024.0	2048.0

XV386

I/O Specifications

Analog Input		
Channels	4	
Type	Ch0	±15 V, ±30 V
	Ch1 ~ Ch3	±1 V, ±2.5 V, ±5 V, ±10 V ±20 mA, 0~20 mA, 4~20 mA (Jumper Selectable)
Resolution	16-bit	
Sampling Rate	Normal Mode	10 Hz
	Fast Mode	200 Hz
Accuracy	Normal Mode	±0.1%
	Fast Mode	±0.5%
Input Impedance	20 MΩ	
Overvoltage Protection	+120 V _{DC}	
Individual Channel Configuration	Yes	
Open Wire Detection	Ch1 ~ Ch3	Yes
Digital Input/Counter		
Channels	4	
Type	Wet Contact	
Sink/Source (NPN/PNP)	Sink/Source	
On Voltage Level	+3.5 V _{DC} ~ +50 V _{DC}	
Off Voltage Level	+1 V _{DC} Max.	
Input Impedance	10 KΩ, 0.5W	
Counter	Channels	4
	Max. Count	4,294,967,285 (32-bit)
	Max. Input Frequency	50 Hz
	Min. Pulse Width	10 ms
Overvoltage Protection	+70 V _{DC}	
Relay Output		
Channels	4	
Type	Power Relay (Form A)	
Contact Material	Silver Cadmium Alloy	
Contact Rating	6 A @ 35 V _{DC} 6 A @ 240 V _{AC}	
Operate Time	5 ms (typical)	
Release Time	1 ms (typical)	
Mechanical Endurance	30 X 10 ⁶ ops.	
Electrical Endurance	1 X 10 ⁵ ops.	
Power-on Value	Yes, Programmable	

Pin Assignment



Internal I/O Structure

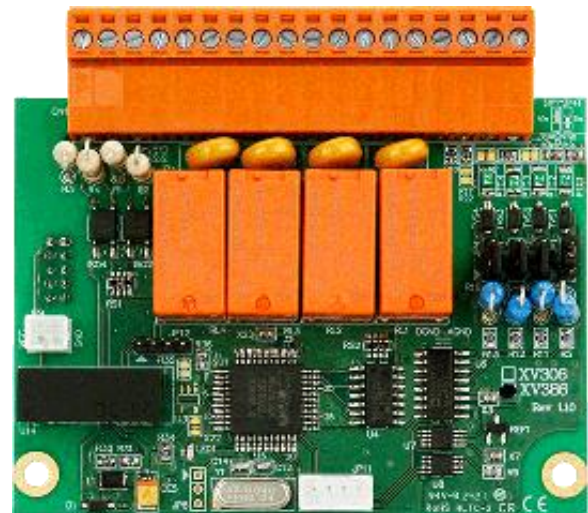
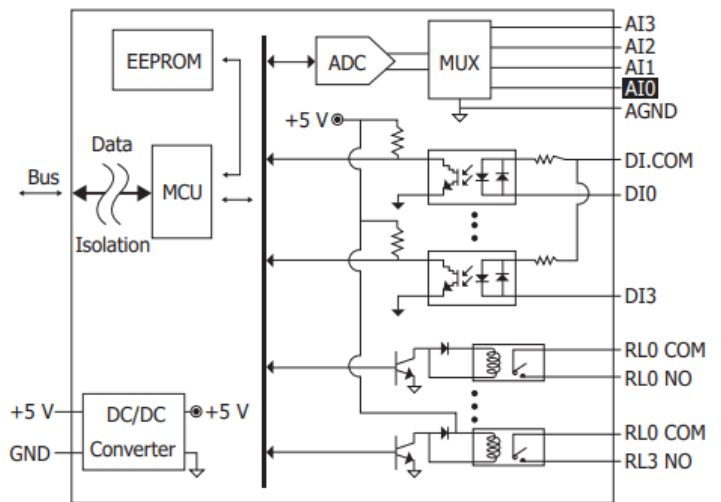

Wire Connections

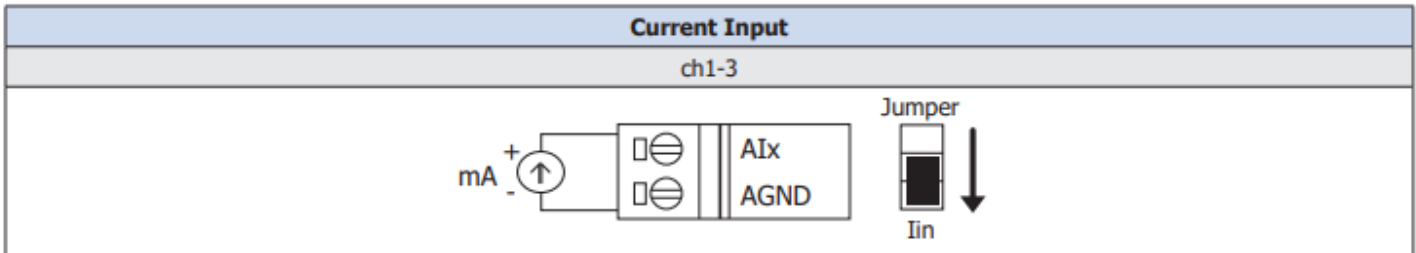
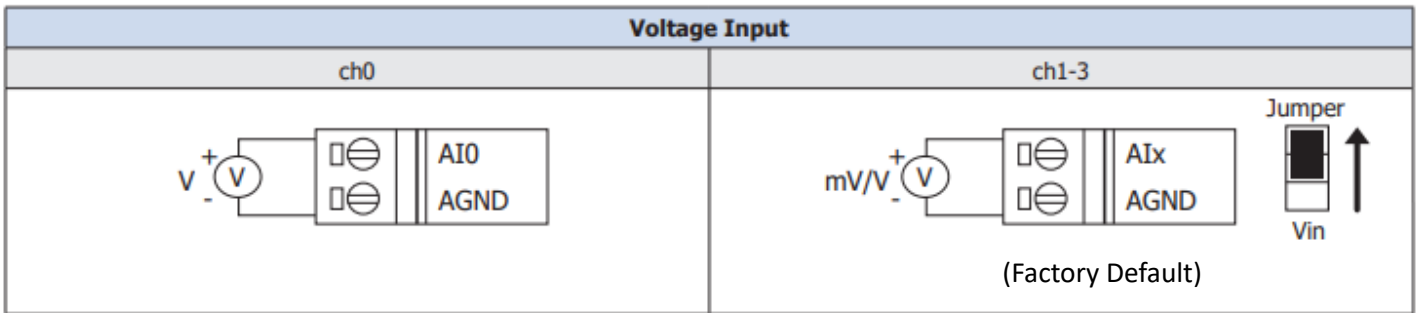

Digital Input/Counter	Readback as 1	Readback as 0
	+3.5 ~ +50 VDC	+1 VDC Max.
Wet Contact (Sink)		
	+3.5 ~ +50 VDC	+1 VDC Max.
Wet Contact (Source)		
	Readback as 1	Readback as 0
Power Relay		

Modbus Register Table

Coils (0xxxx)

Register		Points	Description	Data Format	Attribute	Factory Default
DEC	HEX					
00000 : 00003	0000 : 0003	4	DO value	0: Off 1: On	R/W	-
00160 : 00163	00A0 : 00A3	4	Set the Power-on value of DO	0: Off 1: On	R/W	0
00192 : 00195	00C0 : 00C3	4	Set the trigger mode of DI counter	0: Counted at falling edge 1: Counted at rising edge	R/W	0
00263	0107	1	Clear latched DIO status	1: Clear	W	-
00264	0108	1	Enable/Disable the inverse operation of DI signal	0: Disable 1: Enable	R/W	0
00265	0109	1	Enable/Disable the inverse operation of DO signal	0: Disable 1: Enable	R/W	0
00268	010C	1	Set the AI data format	0: Hexadecimal format 1: Engineering unit	R/W	0
00270	010E	1	Set the AI sampling rate	0: Normal mode (10 Hz) 1: Fast mode (200 Hz)	R/W	0
00512 : 00515	0200 : 0203	4	Clear the DI counter value	1: Clear	W	-

Discrete Inputs (1xxxx)

Register		Points	Description	Data Format	Attribute
DEC	HEX				
10032 : 10035	0020 : 0023	4	DI value	0: Off 1: On	R
10064 : 10067	0040 : 0043	4	Read "high latch" status of DI	0: Normal 1: Latched	R
10096 : 10099	0060 : 0063	4	Read "low latch" status of DI	0: Normal 1: Latched	R
10225 : 10227	00E1 : 00E3	3	Read the open or broken wire detection status of AI (Ch1 ~ Ch3) using 4 mA ~ 20 mA input type (*1)	0: Normal 1: Wire Opened	R

*1: Only the 4 ~ 20 mA of AI supports open or broken wire detection

Input Register (3xxxx)

Register		Points	No. Per Point	Description	Data Format	Attribute
DEC	HEX					
30000 : 30003	0000 : 0003	4	1	AI value	-32768 to 32767 (0x0000 to 0xFFFF)	R
30128 : 30135	0080 : 0087	4	2	DI counter value Each 32-bit counter is calculated by formula: register_high x 65536 + register_low Example: Register_low=0x5678 Register_high=0x1234 32-bit value = 0x1234 x 65536 + 0x5678 = 0x12345678	0 to 4294967295	R

Holding Register (4xxxx)

Register		Points	No. Per Point	Description	Data Format	Attribute	Factory Value
DEC	HEX						
40256	0100	1	1	Set the AI range	0x1E: ±30V 0x1F: ±15V	R/W	0x1E
40257 : 40259	0101 : 0103	3	1	* The jumper associated with an AI channel needs be set to voltage input or current input correctly to meet the AI range setting for the same channel.	0x05: ±2.5 V 0x06: ±20 mA 0x08: ±10 V 0x09: ±5 V 0x0A: ± 1 V 0x0D: ±20 mA 0x1A: 0~20 mA 0x1D: 4 ~ 20 mA	R/W	0x08
40480	01E0	1	1	Firmware version (low word)	0 to 255	R	-
40481	01E1	1	1	Firmware version (high word)	0 to 255	R	-
40482	01E2	1	1	Module name (low word), 0x8600	-	R	-
40483	01E3	1	1	Module name (high word), 0x5603	-	R	-
40489	01E9	1	1	Enable/Disable the AI channel * Each bit corresponds to one channel. * Disable an unused AI channel can increase the sampling rate of the using channels. Sampling rage per channel = $\frac{[\text{Total sampling rate}]}{[\text{Enabled channel count}]}$	0x00 ~ 0xFF Bit N=0: Disable the channel N Bit N=1: Enable the channel N	R/W	0x0F

Analog Input Range

Type Code	Range	Data Format	Minimum	Maximum	Open Wire (Broken Wire)
05	+/- 2.5 V	Engineering	-25000	+25000	-
		Hexadecimal	8000h	7FFFh	
06	+/- 20 mA	Engineering	-20000	+20000	-
		Hexadecimal	8000h	7FFFh	
08	+/- 10 V	Engineering	-10000	+10000	-
		Hexadecimal	8000h	7FFFh	
09	+/- 5 V	Engineering	-5000	+5000	-
		Hexadecimal	8000h	7FFFh	
0A	+/- 1 V	Engineering	-10000	+10000	-
		Hexadecimal	8000h	7FFFh	
0D	+/- 20 mA	Engineering	-20000	+20000	-
		Hexadecimal	8000h	7FFFh	
1A	0 ~ 20 mA	Engineering	0	+20000	-
		Hexadecimal	0000h	FFFFh	
1D	4 ~ 20 mA (*2)	Engineering	+4000	+20000	0
		Hexadecimal	1999h	7FFFh	0000
1E	+/- 30 V (*3)	Engineering	-30000	+30000	
		Hexadecimal	8000h	7FFFh	
1F	+/- 15 V (*3)	Engineering	-15000	+15000	
		Hexadecimal	8000h	7FFFh	

*2: Only the 4 ~ 20 mA of AI supports open or broken wire detection.

*3: Type codes "1E" and "1F" only apply to channel 0 of AI, other type codes do not apply to this channel.

XV484

I/O Specifications

Counter/Frequency/Encoder Input	
Channels	4-ch Up/Down Counter (CW/CCW) 4-ch Dir/Pulse Counter (Bi-direction) 4-ch A/B Phase Counter (Quadrant Counting) 8-ch Up Counter 8-ch Frequency
Contact	Wet
Sink/Source (NPN/PNP)	Sink
Types	Counter, Frequency or Encoder
Counter/Encoder-bits	32-bit (4,294,967,295)
ON Voltage Level	+3.5 VDC ~ +30 VDC
OFF Voltage Level	+1 VDC Max.
Programmable Digital Filter	1 ~ 32767 μ s
Individual Channel Configuration	Yes
Counter Mode	Up or Up/Down
Encoder Mode	CW/CCW, Dir/Pulse, AB Phase
Frequency Mode	Yes
Max. Speed	3.5 VDC ~ 10 VDC: 200 kHz 10 VDC ~ 30 VDC: 150 kHz
Frequency Accuracy	1 Hz~200 kHz = \pm 0.025% of Input Frequency (*1)
Virtual Battery Backup to Preserve Counter Values	Yes

*1: Frequency error related to input range:

Frequency Range	Frequency Error (typical)
1 Hz ~ 10 Hz	0.01 Hz
10 Hz ~ 10 KHz	0.5 Hz
10 KHz ~ 100 KHz	15 Hz
100 KHz ~ 200 KHz	30 Hz

Pin Assignment

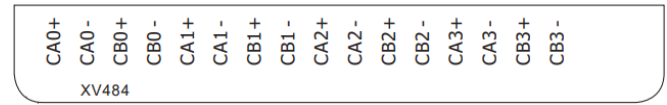

Internal I/O Structure

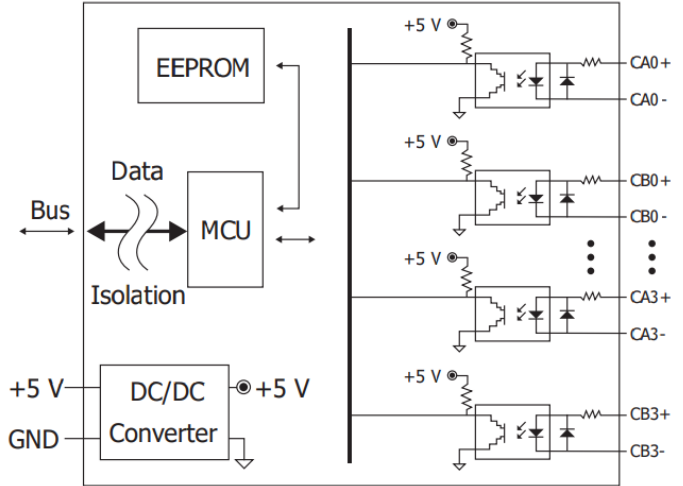

Wire Connections

Counter Type	
Up	<p>Up+ — CAx+ Up- — CAx-</p>
Up/Down	<p>Up+ — CAx+ Up- — CAx- Down+ — CBx+ Down- — CBx-</p>
Dir/Pulse	<p>Pulse+ — CAx+ Pulse- — CAx- Dir+ — CBx+ Dir- — CBx-</p>
A/B Phase	<p>A0+ — CAx+ A0- — CAx- B0+ — CBx+ B0- — CBx-</p>
Frequency Type	
Frequency	<p>Freq+ — CAx+ Freq- — CAx-</p>

Modbus Register Table

Coils (0xxxx)

Register		Points	Description	Data Format	Attribute	Factory Default
DEC	HEX					
00032 : 00039	0020 : 0027	8	Input status after XOR mask for channel 0 to 7.	0: Off 1: On	R	-
00040 : 00047	0028 : 002F	8	Input status after low-pass filter for channel 0 to 7.	0: Off 1: On	R	0
00064 : 00071	0040 : 0047	8	Counter overflow status for channel 0 to 7. Write 1 to clear overflow status.	0: Normal 1: Overflow occurs	R/W	0
00268	010C	1	Data format for frequency type.	0: Hex 1: Float	R/W	-
00512 : 00519	0200 : 0207	8	Write 1 to clear counter 0 ~ 7.	-	W	-
00768 : 00775	0300 : 0307	8	Enable battery backup for counter 0 to 7	0: Disable 1: Enable	R/W	-
00800 : 00807	0320 : 0327	8	Automatic switching between high/low frequency mode for frequency measurement of channel 0 to 7	0: Disable 1: Enable	R/W	-
00832 : 00839	0340 : 0347	8	High/low frequency mode for frequency measurement of channel 0 to 7 It is recommended to set to high frequency mode for frequency larger than 10 KHz.	0: Low 1: High	R/W	-
00864 : 00871	0360 : 0367	8	Stop counting on counter overflow for channel 0 to 7	0: Keep counting 1: Stop	R/W	-
00896 : 00903	0380 : 0387	8	Enable low pass filter for channel 0 to 7.	0: Disable 1: Enable	R/W	-
00928 : 00935	03A0 : 03A7	8	XOR mask for channel 0 to 7.	-	R/W	-

Input Register (3xxxx)

Register		Points	No. Per Point	Description	Data Format	Attribute
DEC	HEX					
30000 : 30015	0000 : 000F	8	2	Counter/frequency value of channel 0 to 7 Each 32-bit counter is calculated by formula: register_high x 65536 + register_low Example: Register_low=0x5678 Register_high=0x1234 32-bit value = 0x1234 x 65536 + 0x5678 = 0x12345678	0 to 4294967295	R

Holding Register (4xxxx)

Register		Points	No. Per Point	Description	Data Format	Attribute	Factory Value
DEC	HEX						
40064 : 40079	0040 : 004F	8	2	Maximum value for up counter 0 to 7, two registers for each channel	0 to 4294967295	R/W	-
40096 : 40111	0060 : 006F	8	2	Preset value of counter 0 to 7, two registers for each channel	0 to 4294967295	R/W	-
40160	00A0	1	1	Frequency measurement timeout in 100ms	1 to 255	R/W	-
40161	00A1	1	1	Low-pass filter time for channel 0 and 1 in μ s	1 to 32767	R/W	-
40162	00A2	1	1	Low-pass filter time for channel 2 and 3 in μ s	1 to 32767	R/W	-
40163	00A3	1	1	Low-pass filter time for channel 4 to 7 in μ s	1 to 32767	R/W	-
40256 : 40263	0100 : 0107	8	1	Type code of channel 0 to 7		R/W	-
40480	01E0	1	1	Firmware version (low word)	0 to 255	R	-
40481	01E1	1	1	Firmware version (high word)	0 to 255	R	-
40482	01E2	1	1	Module name (low word), 0x8400	-	R	-
40483	01E3	1	1	Module name (high word), 0x5604	-	R	-
40489	01E9	1	1	Start/stop counting, bit 0 for ch0, bit 1 for ch1, ...	Bit 0 to 7 0: Stop 1: Start	R/W	-

Counter Type and Data Format Table

Type Code	Counter Type	Data Format	Minimum	Maximum
50	Up	Hexadecimal	00000000h	FFFFFFFFh
54	Up/down	Hexadecimal	80000000h	7FFFFFFFh
55	Pulse/direction	Hexadecimal	80000000h	7FFFFFFFh
56	Quadrature	Hexadecimal	80000000h	7FFFFFFFh

Up/down Counting

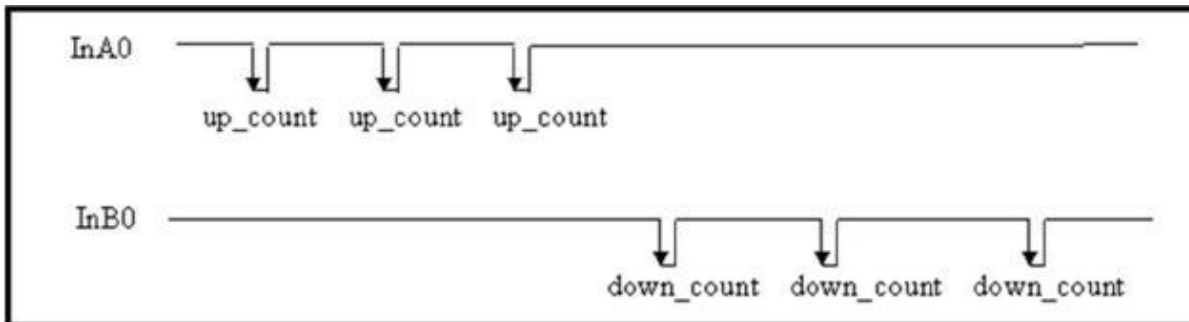

When InA0 is used as an up counting clock and InB0 is used as a down counting clock, the counter will be increased by one for every falling edge of InA0 and decreased by one for every falling edge of InB0.

Pulse/direction Counting

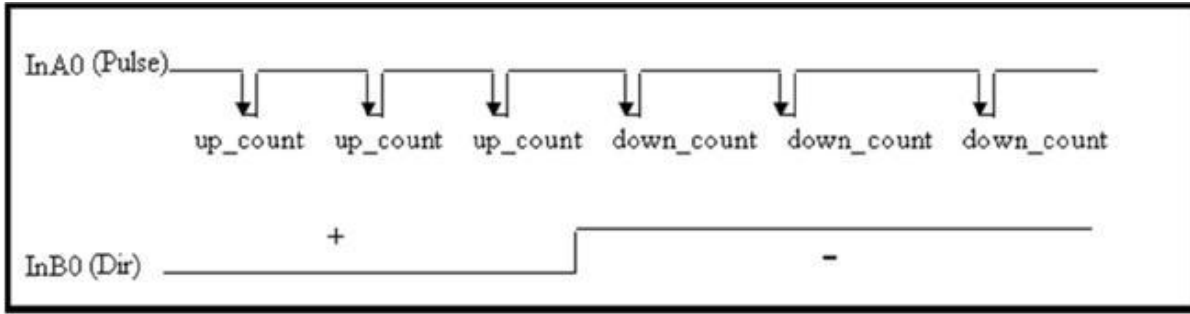

The InB0 is used for direction counting. When InB0 is low, the counter will be increased by one for every falling edge of InA0. When InB0 is high, the counter will be decreased by one for every falling edge of InA0.

Quadrature Counting

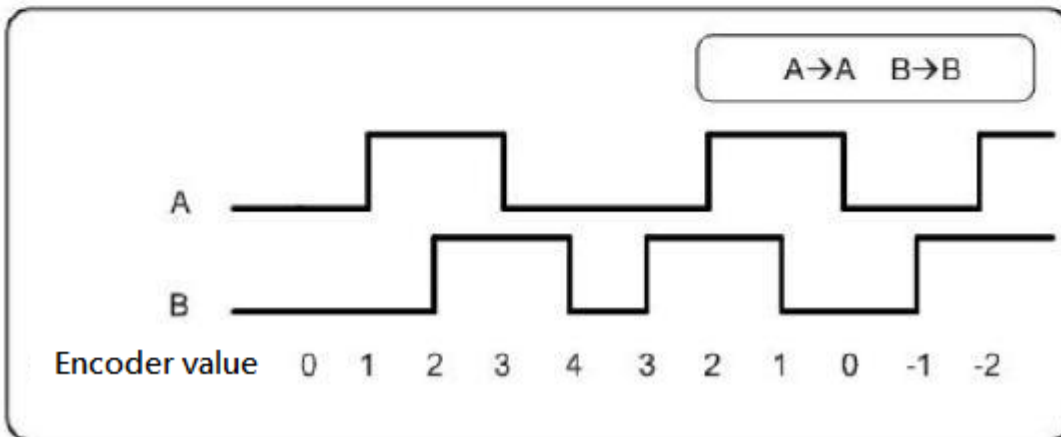
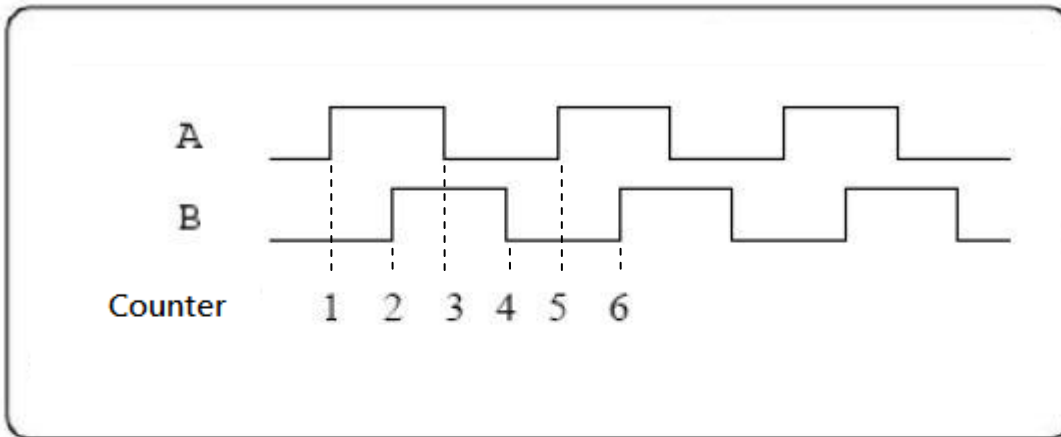

When InA0 is used as the A signal and InB0 is used as the B signal, the counter will be increased by one when the InA0 phase leads by 90 degrees to InB0 and the counter will be decreased by one when the InA0 phase lags by 90 degrees to InB0.

Revision History

Revision	Date	Description
1.0.6	2025/07	Added information for XV119.
1.0.5	2025/03	Added information for XV315 and XV386.
1.0.4	2019/10	Added XV484 information.
1.0.3	2018/08	Added XV303 information.
1.0.2	2016/05	Added DI counter specification and Modbus address information for XV-107/107A/110/116 with firmware version 1.00.
1.0.1	2015/05	Added Coil Register 00268 for XV306 and XV307.
1.0.0	2015/01	First released