

MDCL-705i

User Manual

June 2025, Version 1.0.1



Written by Liam Lin
Edited by Sunny Chiu

Warranty

All products manufactured by ICP DAS are warranted against defective materials for a period of one year from the date of delivery to the original purchaser.

Warning

ICP DAS assumes no liability for damages consequent to the use of this product.

ICP DAS reserves the right to change this manual at any time without notice. The information furnished by ICP DAS is believed to be accurate and reliable. However, no responsibility is assumed by ICP DAS for its use, nor for any infringements of patents or other rights of third parties resulting from its use.

Copyright

Copyright © 2021 by ICP DAS. All rights are reserved.

Contact Us

If you have any questions, please feel free to contact us via email at:

Service@icpdas.com

Contents

1. Introduction	4
2. Hardware Information	11
2.1. Specifications	11
2.2. Appearance	13
2.3. Pin Assignments	16
2.4. Wiring Connections	17
2.5. Dimensions	18
2.6. Mounting the Hardware	19
3. Getting Started.....	21
4. System Configuration.....	27
4.1. Network Configuration	27
4.2. Authentication and Access Control	29
4.3. Date and Time.....	31
4.4. FTP Server Configuration	33
4.5. Log File Manager	35
4.6. Firmware Update	37
5. Modbus Configuration	38
5.1. COM Port Configuration	38
6. MDC Configuration (config.csv)	41
6.1. Exporting/Importing the Config.csv File.....	41
6.2. Configuring polling definition	44
6.3. Verifying Polling Definitions.....	46
6.4. Application	47
7. Data Logger Configuration (record.csv)	58
7.1. Logging Interval Configuration	59
7.2. Exporting/Importing the Record.csv File	61
7.3. Logging Channels Configuration (Record.csv)	63
7.4. Viewing Log Channel Settings.....	71
7.5. Downloading Log Files	72
7.6. Application	76
8. Troubleshooting.....	84
9. FAQ.....	87
Revision History	96

1. Introduction

The MDCL-705i module is a Modbus Data Concentrator with data logger function. It offers 5 COM ports to collect data from multiple Modbus RTU slave devices, and makes the data accessible to Modbus TCP masters over an Ethernet/LAN connection.

With the MDCL module, a Modbus master can retrieve the same type of data from different RTU slave devices using just one Modbus command, significantly improving communication efficiency. In other words, it allows Modbus RTU devices to be accessed over Ethernet with enhanced read/write performance.

The module supports up to 250 Modbus RTU commands for collecting data from slave devices, and can simultaneously serve up to 8 Modbus TCP masters. It also features a data logger that can record up to 120 points for long-term monitoring. Users can download the log files in CSV format through the web interface or automatically upload them to an FTP server for advanced analysis.

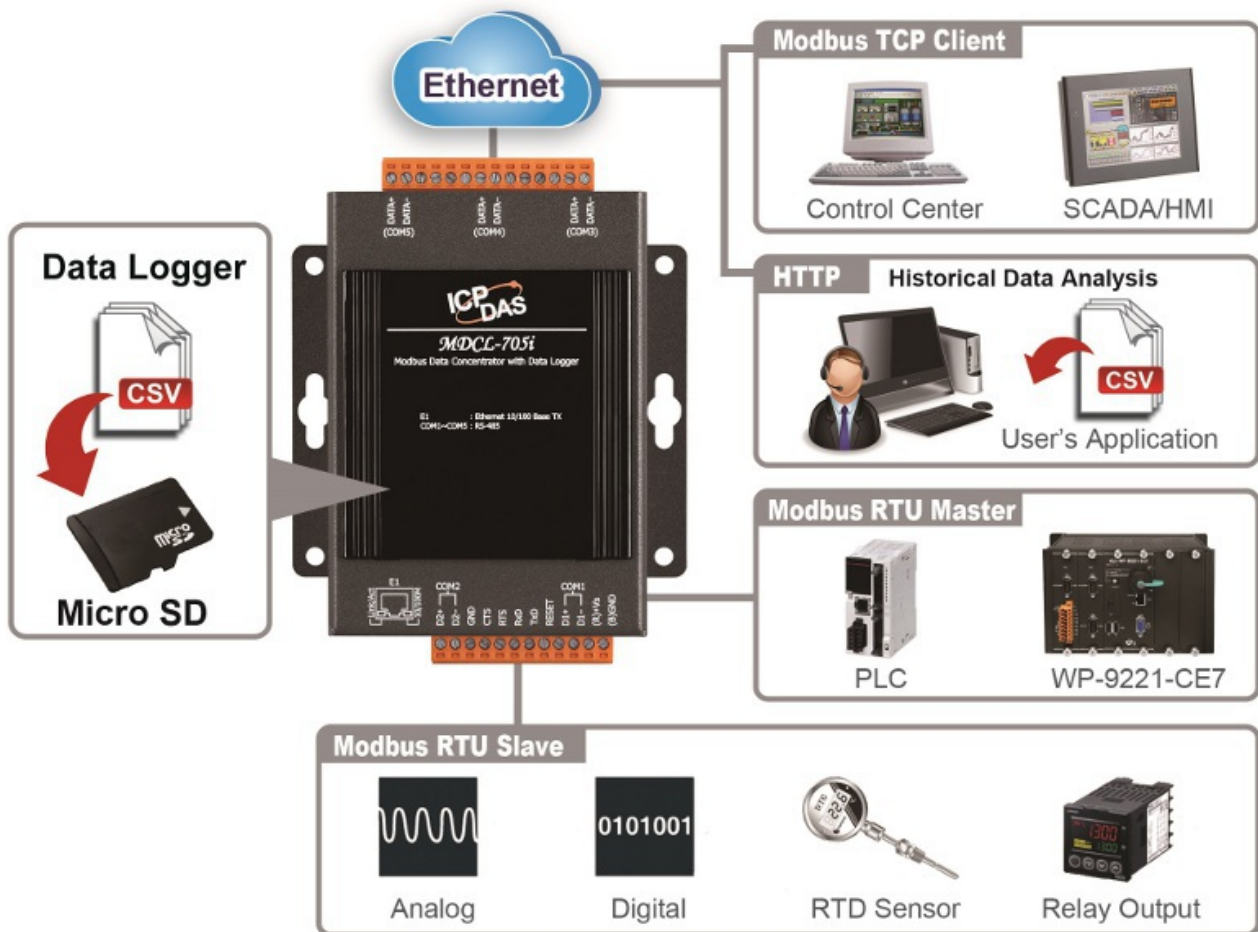

Features

HTML5 Web-based User Interface

HTML5 is the latest version of the HTML markup language. It is supported by most current browsers including Mozilla Firefox, Apple Safari, Microsoft Edge, Google Chrome and so on.

Thanks to this compatibility, the MDCL-705i's web-based user interface can be accessed from a wide range of devices, anytime and anywhere. Users can configure the module and monitor the connection status of each polling definition directly from their smartphones, tablets, or desktop computers—no coding required.

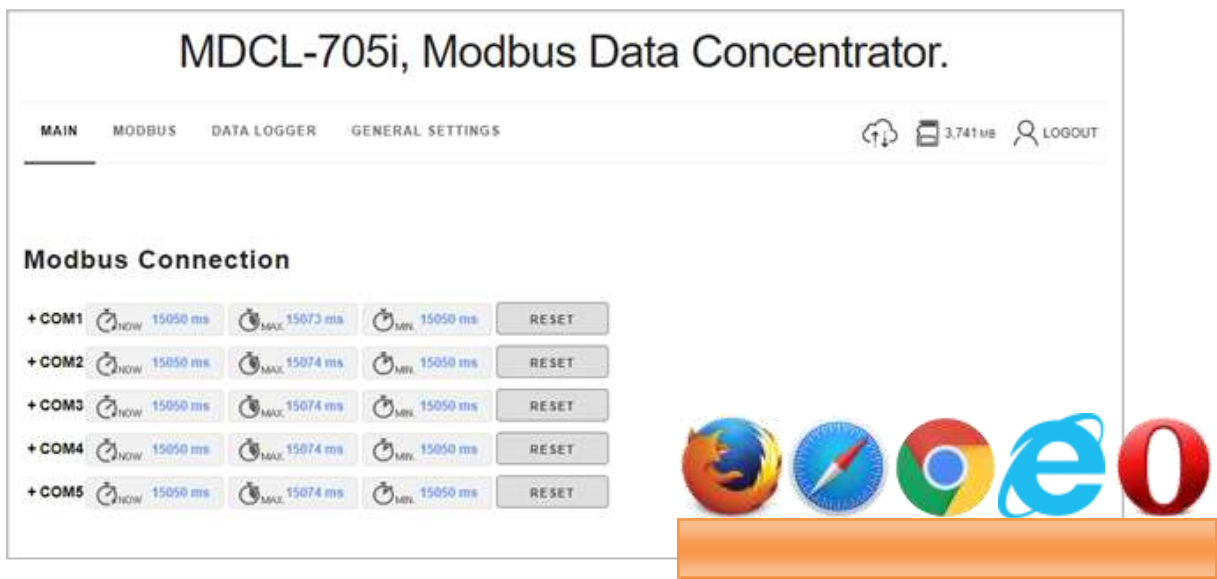

Great Capability of Shared Memory

The MDCL-705i module can store and process up to 250 polling definitions, offers 9,600 registers for each data type (AI, AO, DI, DO). It arranges data from different devices into continuous addresses, so a remote computer can read them all with one command. This simplifies programming and lowers network traffic.

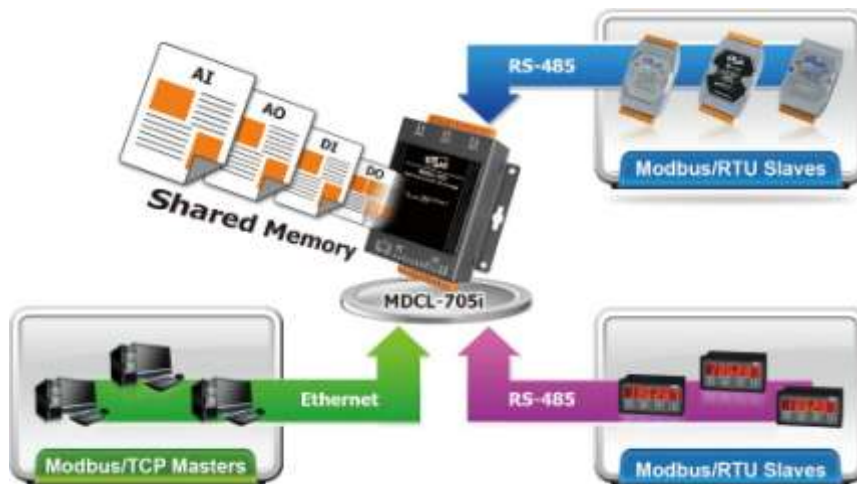

Editing CSV files to Ease Hard Work of Managing Definitions and Logs

Editing and checking a lot of polling definitions or log channel settings is hard work and is easy to make mistakes. Using CSV files to manage so many configurations with Excel makes it easy; the CSV files can be imported or exported from the module via a simple mouse-click action.

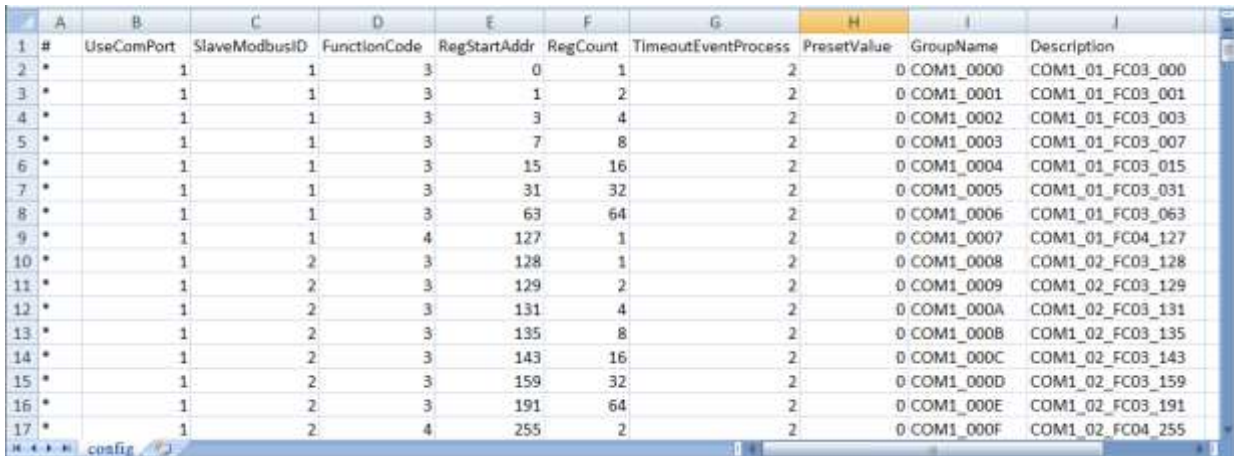

#	UseComPort	SlaveModbusID	FunctionCode	RegStartAddr	RegCount	TimeoutEventProcess	PresetValue	GroupName	Description
2	*	1	1	3	0	1	2	0 COM1_0000	COM1_01_FC03_000
3	*	1	1	3	1	2	2	0 COM1_0001	COM1_01_FC03_001
4	*	1	1	3	3	4	2	0 COM1_0002	COM1_01_FC03_003
5	*	1	1	3	7	8	2	0 COM1_0003	COM1_01_FC03_007
6	*	1	1	3	15	16	2	0 COM1_0004	COM1_01_FC03_015
7	*	1	1	3	31	32	2	0 COM1_0005	COM1_01_FC03_031
8	*	1	1	3	63	64	2	0 COM1_0006	COM1_01_FC03_063
9	*	1	1	4	127	1	2	0 COM1_0007	COM1_01_FC04_127
10	*	1	2	3	128	1	2	0 COM1_0008	COM1_02_FC03_128
11	*	1	2	3	129	2	2	0 COM1_0009	COM1_02_FC03_129
12	*	1	2	3	131	4	2	0 COM1_000A	COM1_02_FC03_131
13	*	1	2	3	135	8	2	0 COM1_000B	COM1_02_FC03_135
14	*	1	2	3	143	16	2	0 COM1_000C	COM1_02_FC03_143
15	*	1	2	3	159	32	2	0 COM1_000D	COM1_02_FC03_159
16	*	1	2	3	191	64	2	0 COM1_000E	COM1_02_FC03_191
17	*	1	2	4	255	2	2	0 COM1_000F	COM1_02_FC04_255

Built-in definition validation

One of the polling definitions may not be executed due to invalid parameters is given in the imported config.csv file. The MDCL module provides the function of validating and displaying invalid parameters with line information in config.csv file on its web interface.

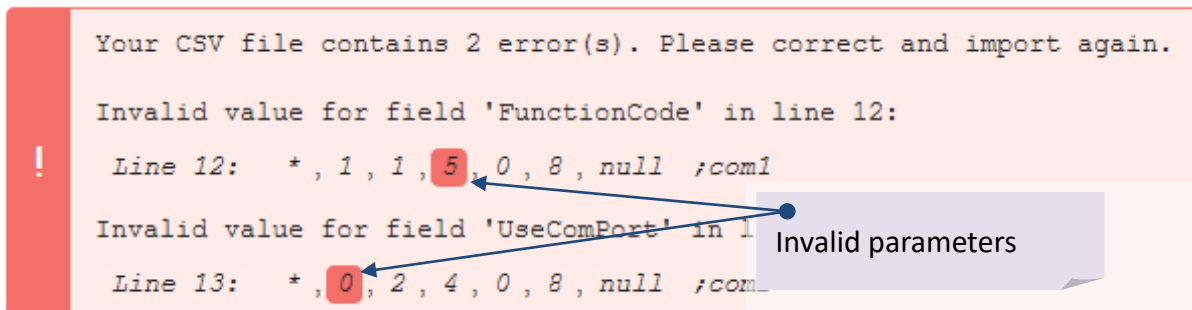

Support for Modbus TCP master and Modbus RTU master

In addition to allowing a Modbus TCP master to read data from slave devices over Ethernet, the MDCL-705i also supports switching the COM port mode to enable communication with Modbus RTU masters. This flexible design allows on-site hosts to obtain real-time data in the same efficient way.

Support Data Logging

- Up to 120 parameters per record with ratio and offset conversion functions.
- Selectable data logging time interval from 5 seconds to 6 hours.
- Built-in 32GB microSD card.
- Log file time period varies from 1 to 24 hours.
- Download the required data from the web interface, or upload it to the FTP server.

Automatic data transfer via FTP

If the **Automatic File Upload** function is enabled, the MDCL-705i will automatically upload the file to the specified FTP Server when the file is finished recording. The fully automated operation can seamlessly connect to subsequent data processing, greatly saving time and labor costs.

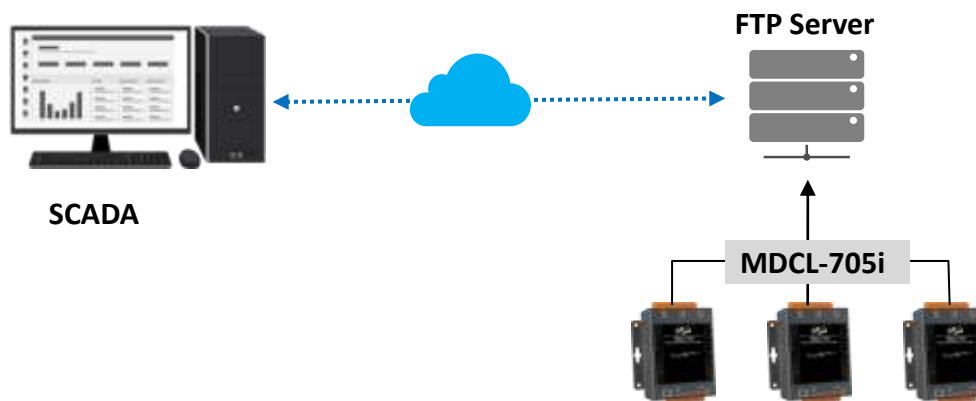

Authentication and Access Control

The authentication and access control features help prevent unauthorized users from accessing key information or modifying system settings. The Administrator can create a user account with restricted permissions— view device connection statuses and limited configuration details only. This design helps protect the MDCL-705i from unintended setting changes during operations.

Supports NTP client

NTP stands for Network Time Protocol and it is a networking protocol for clock synchronization between computer systems. It is used to synchronize computer clock times in a network.

In order to ensure the data logged with correct timestamps, an NTP server can be set by IP address or name on the MDCL-705i to synchronize the date and time information based on the specified schedule.

Timestamp alignment

Data from multiple sensors and devices must be time-aligned for accurate analysis. However, variations in sampling rates and recording times across different locations or devices often make aligning these data streams a complex and time-consuming task. MDCL offers an intelligent solution that delivers nearly time-synchronized data, allowing users to start analysis immediately without extra coding or manual synchronization.

1. Support NTP time synchronization.

MDCL has a built-in Real Time Clock, and records data with timestamps. To increase the accuracy of system time in the RTC, MDCL can be configured to execute automatic time correction from the NTP server on the network, or manually set to synchronize its clock with the time of your local PC or an NTP server.

2. Generate filename with creation date and time.

MDCL provides a consistent name format for log files that allows you to identify them. The file name begins with a "T_" prefix followed by the creation date and time in MMDDHH format.

3. Align log intervals to clock time

The MDCL supports log intervals ranging from 5 seconds to 6 hours. The data logging intervals are aligned to standard clock times - not based on when logging starts.

- If the interval is ≤ 1 minute, data is logged at the 0-second mark of each minute, and then at every fixed interval thereafter.
- If the interval is ≤ 1 hour, data is logged at the top of each hour (00 minutes 00 seconds), and then at every fixed interval thereafter.
- If the interval is > 1 hour, data is logged starting at 00:00:00 each day, followed by every fixed interval.

This design allows multiple MDCL modules to log data synchronously. For example, if three MDCL modules are all set to log data every 15 minutes, their logging times will be aligned at 00:00, 15:00, 30:00, and 45:00 of each hour (excluding the initial entry).

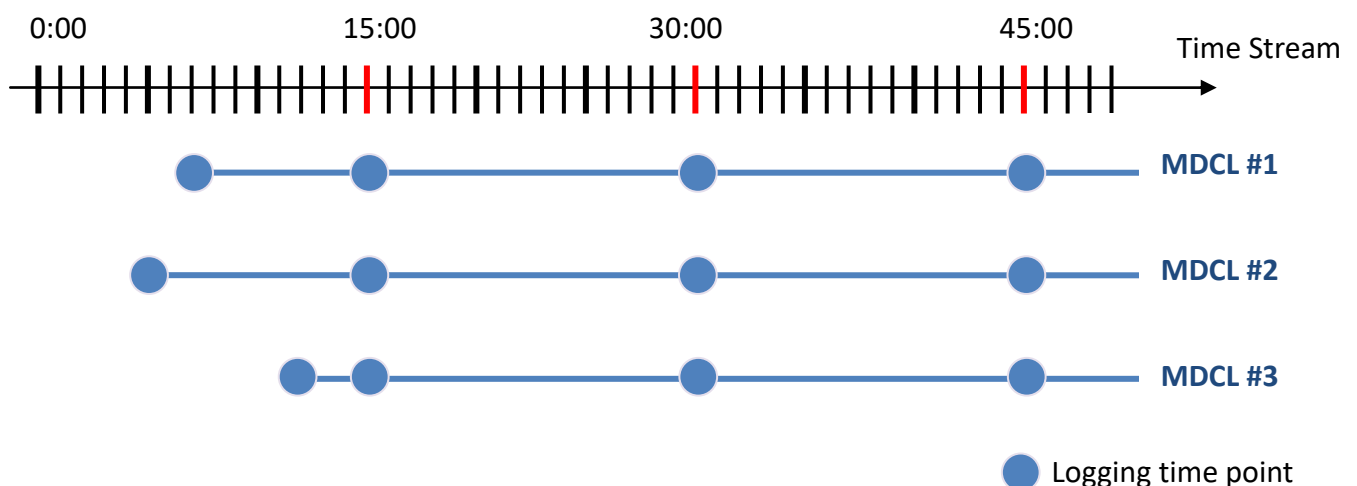

4. Create new log files at regular hour marks

Based on the configured Maximum Logging Period, the MDCL-705i closes the current log file and starts a new one at the beginning of each time interval, which is aligned to absolute clock times such as 00:00:00, 06:00:00, 12:00:00, and so on. This ensures consistent and time-synchronized log files across multiple devices.

For example, if the Maximum Logging Period is set to 6 hours, new log files will be created at 00:00:00, 06:00:00, 12:00:00, and 18:00:00, following a repeating schedule.

Even if three MDCL modules begin logging at different times, applying the same 6-hour Maximum Logging Period ensures that all subsequent log files are created at the same synchronized time points—except for the initial file.

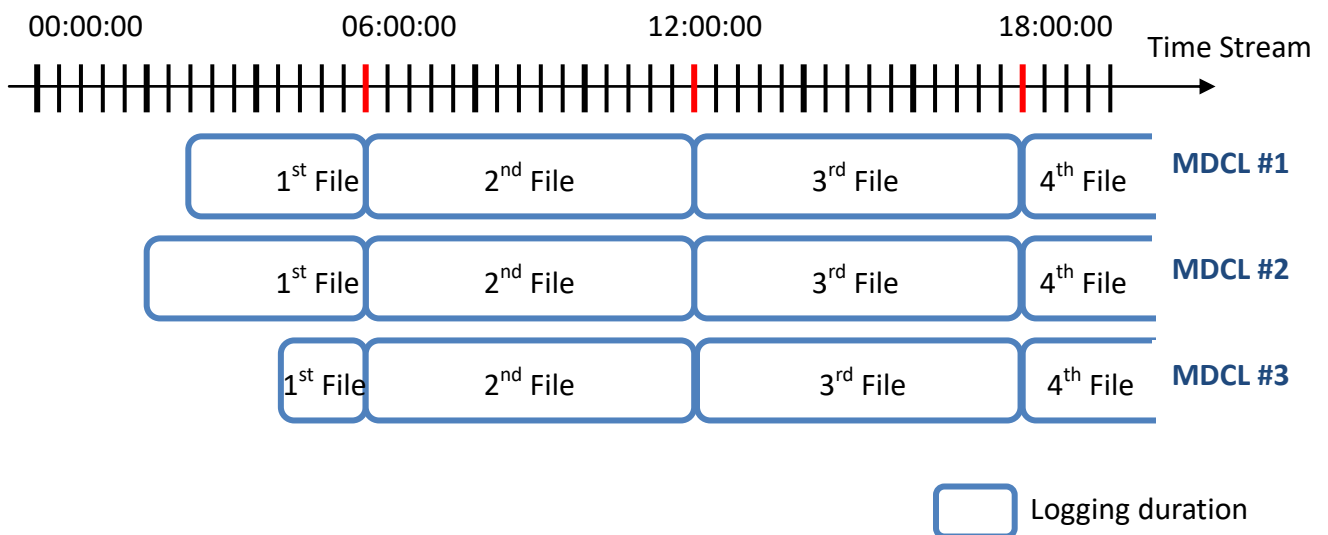

5. Synchronized data logging across multiple modules

When using multiple MDCL modules with the same Logging Rate and Maximum Logging Period settings, the generated data files will share a consistent time reference.

To align the data from different modules, users simply need to replace the “T_” prefix in each file name with the corresponding MDCL module ID or installation location. This mechanism greatly simplifies the data integration process and enhances the efficiency of subsequent data analysis.

Flowchart of based configuration procedure

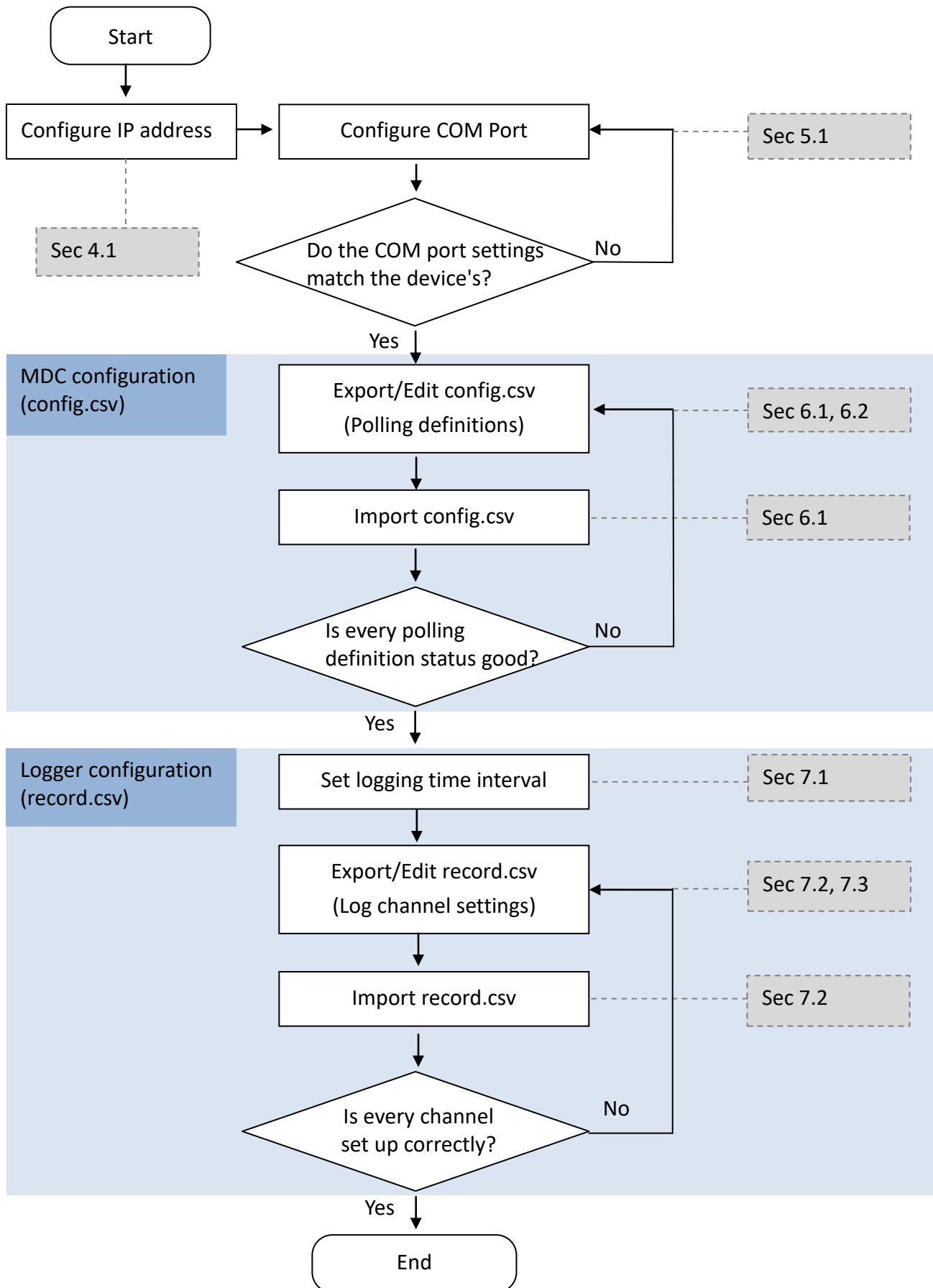

2. Hardware Information

2.1. Specifications

Model	MDCL-705i
Data Logger	
Data Type	Boolean, 16-bit Integer, 32-bit Integer and 32-bit Floating
Max. Recording Period per File	1 hr, 2 hr, 6 hr, 12 hr, 24 hr
File Manager Interface	Built-in web server
Storage Media	microSD Card (Up to 32 GB)
File Format	CSV
Time Interval	5 sec, 10 sec, 30 sec, 1 min, 5 min, 10 min, 15 min, 30 min, 1 hr, 6 hr
Max. Records	120 points per record
Display	
Type	5-Digit 7 Segment LED Display (display system information)
LED Indicators	
Status	1 x System, to (display heartbeat)
COM Port	
RS-232	1 (console port for connection with PC only)
RS-485	2 x 2-wire RS-485 (non-isolated) 3 x 2-wire RS-485 (2.5 kV isolation protection)
Baud Rate	1200, 2400, 4800, 9600, 19200, 38400, 57600, 115200 bps
Data Format	N81, E81, O81
Protocol	Modbus RTU master/Modbus RTU slave
Polling Definition	250 definitions for all RS-485 ports
Shared Memory	9600 registers for each of AI, AO, DI and DO data
Max. Connection	32 slaves for each RS-485 port

Ethernet	
Ports	1 x 10/100 Base-TX
Protocol	Modbus/TCP slave, HTTP
Socket Connections	Up to 8 simultaneous Modbus TCP connections
Power	
Input Range	+10 VDC ~ +48 VDC (non-regulated)
Consumption	2 W
Mechanical	
Casing	Metal
Dimension	97 mm x 120 mm x 42mm (W x L x H)
Installation	DIN-Rail or Wall Mounting
Environmental	
Operating Temperature	-25 ~ +75 °C
Storage Temperature	-30 ~ +80 °C
Humidity	10 ~ 90% RH, Non-condensing

2.2. Appearance

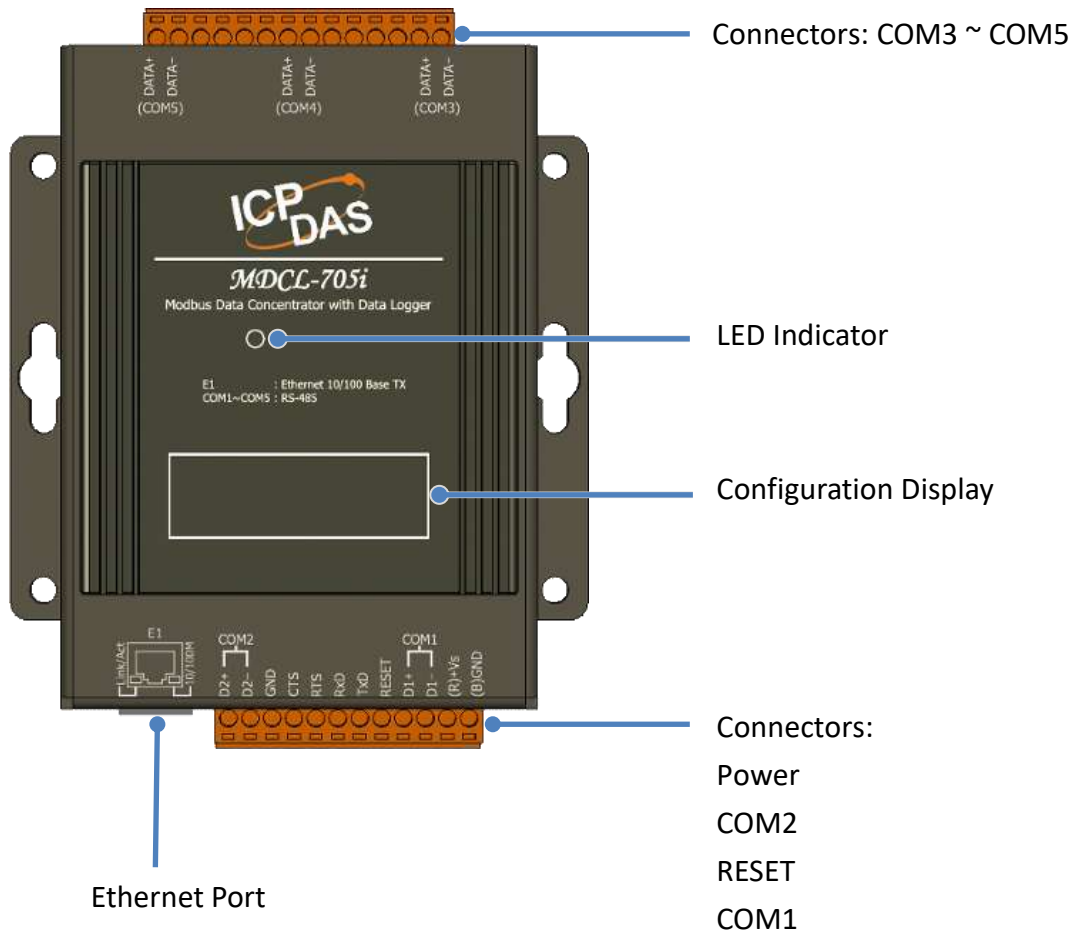

LED indicator

The LED is used as a heartbeat indicator and flashes approximately once per second.

Ethernet Port

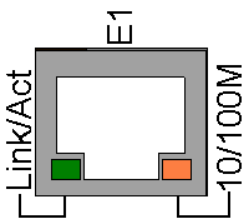

The MDCL-705i features an RJ-45 port supporting 10/100 Mbps Ethernet. When operating at 100BASE-TX, the 10/100M orange LED remains steadily lit. In 10BASE-T mode, the orange LED is off. The Link/Act LED green LED blinks when a network connection is detected and data packets are being received.

Power Connector

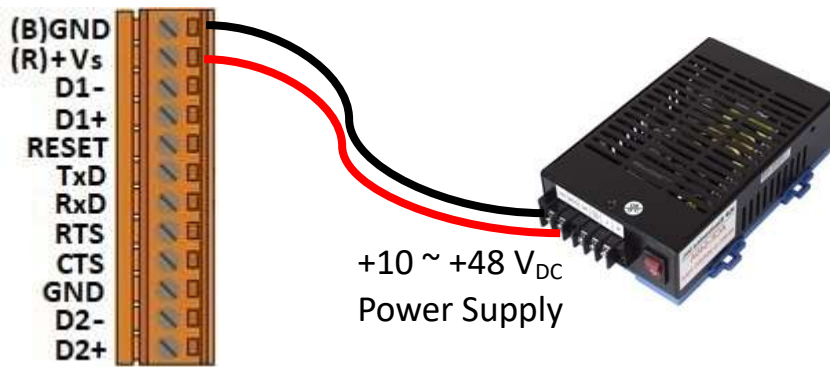

Configuration display

MDCL-705i includes a 5-digit 7-Segment LED display to indicate configuration in the module as below:

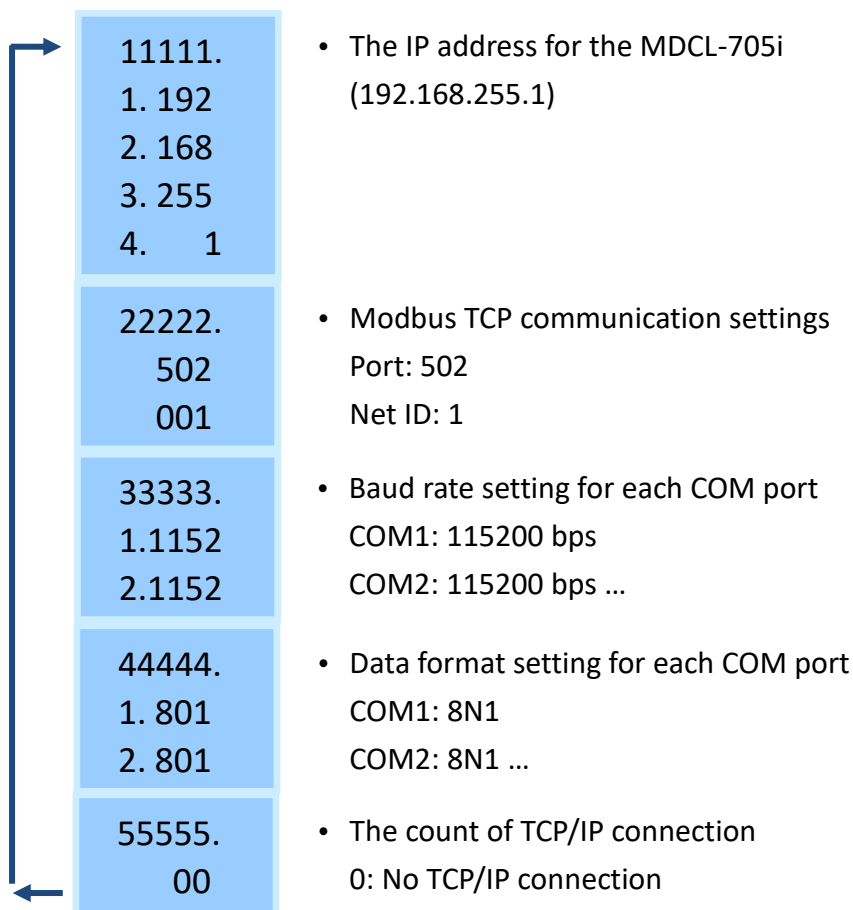

Reset

Shorting the RESET pin to GND pin over 3 seconds can reset the IP/Subnet Mask/Gateway addresses to the factory default settings.

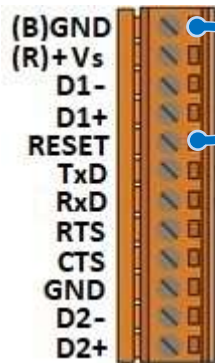

Over **3** seconds to restore factory default settings

2.3. Pin Assignments



Terminal No.	Pin Assignment	Terminal No.	Pin Assignment	
E1		COM5	26 DATA+	
			25 DATA-	
			24	
			23	
			22	
COM2	01 D2+		21	
	02 D2-	COM4	20 DATA+	
03 GND	19 DATA-			
	04 CTS		18	
	05 RTS		17	
	06 RxD		16	
	07 TxD		15	
COM1	08 RESET	COM3	14 DATA+	
	09 D1+		13 DATA-	
	10 D1-			
	11 (R)+Vs			
	12 (B)GND			

2.4. Wiring Connections

RS-232 wiring

3-wire Connection Wiring (Console port for connection with PC only)

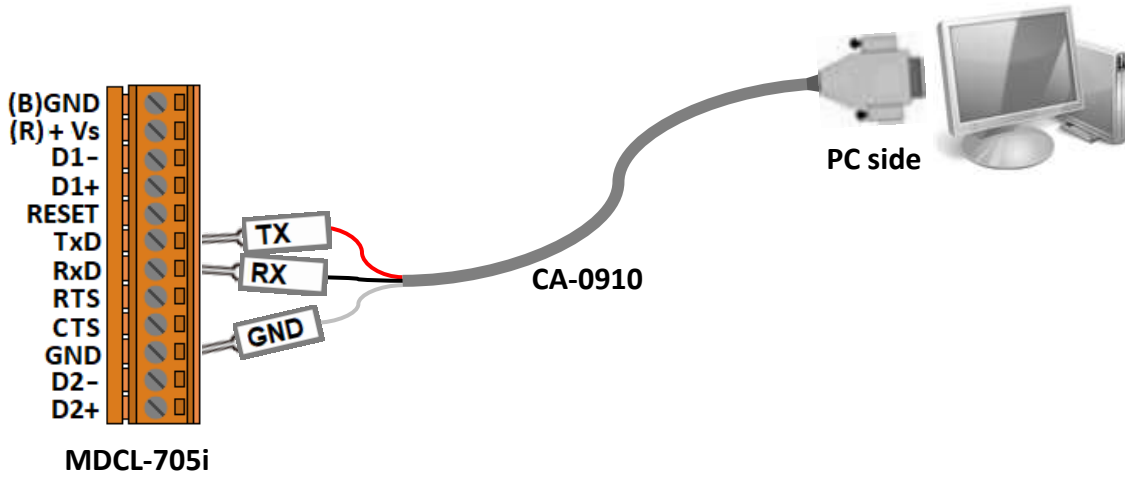

RS-485 wiring

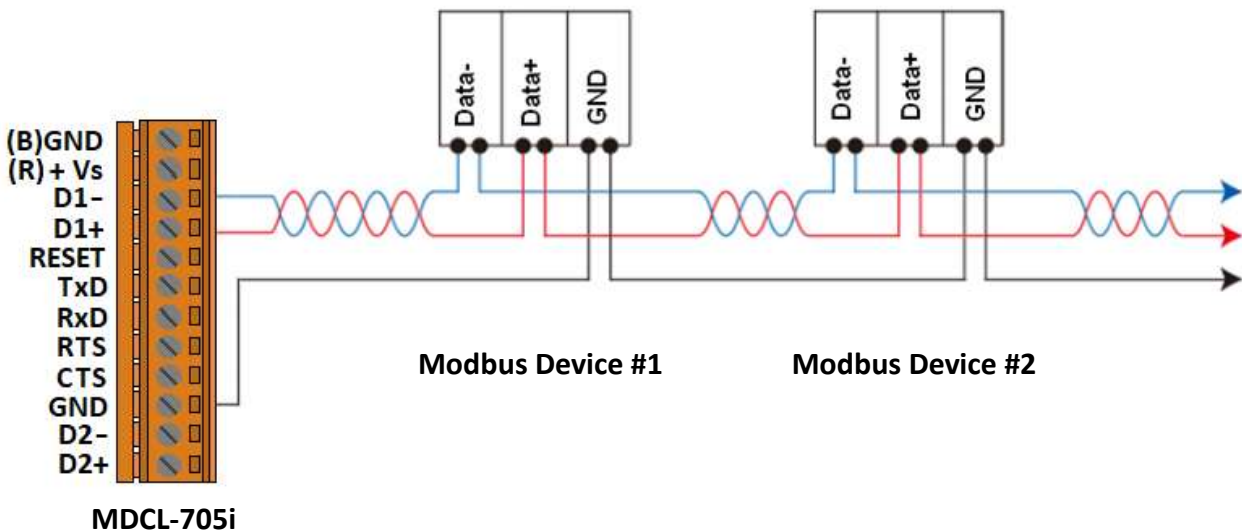

2.5. Dimensions

Unit: mm

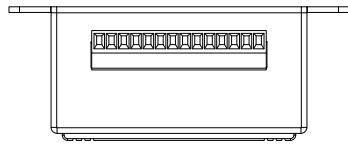

Top View

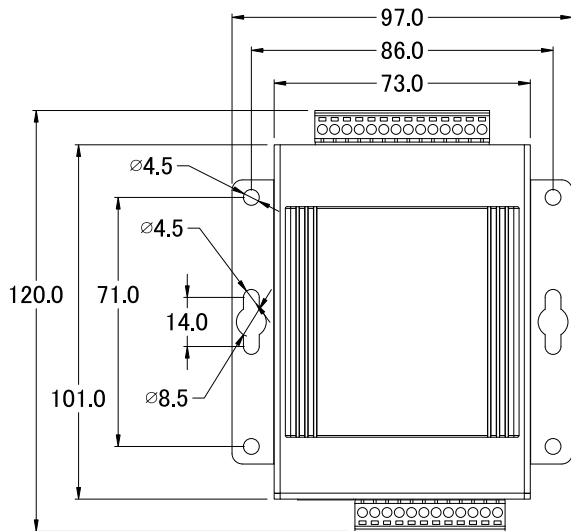

Front View

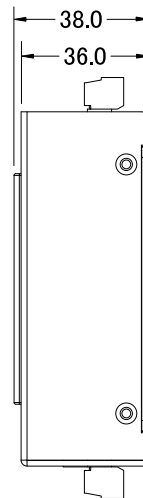

Right Side View

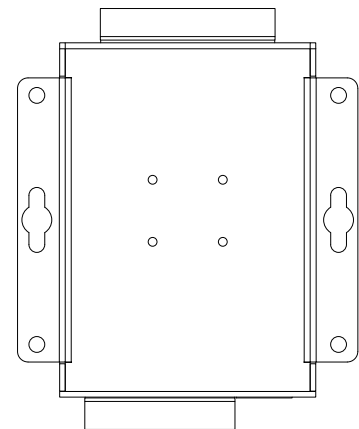

Rear View

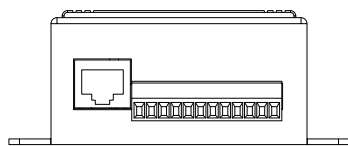

Bottom View

2.6. Mounting the Hardware

DIN Rail mounting

Step 1: Hook upper tab over upper flange of DIN rail.

Step 2: Tilt the module toward DIN rail until it snaps securely to DIN rail

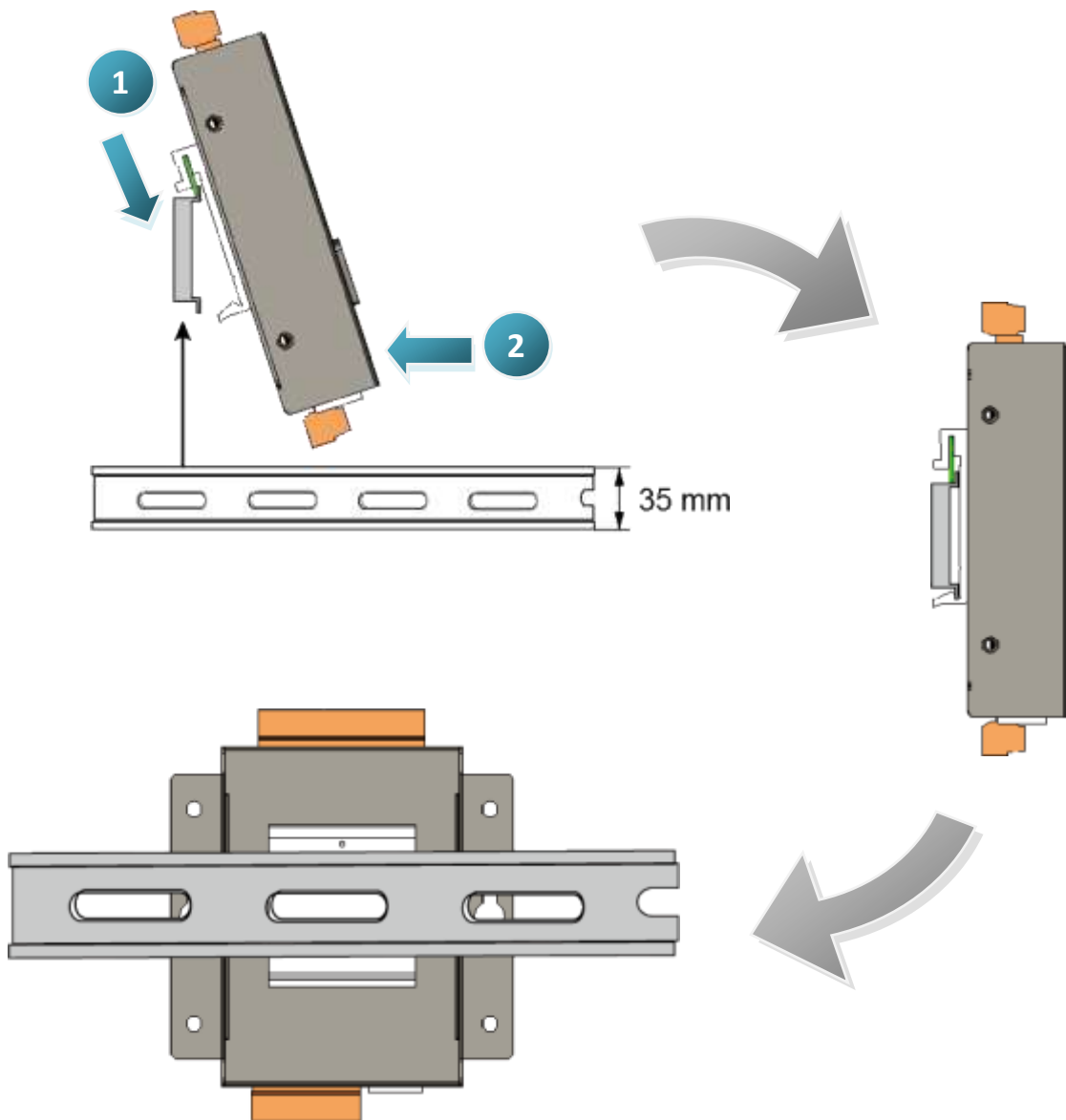

Wall/panel mounting

Step 1: Remove the DIN-Rail mounting accessories on the back of the module.

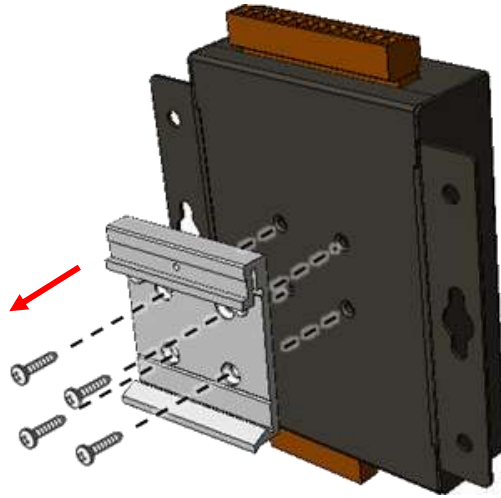

Step 2: Fasten the screws securely.

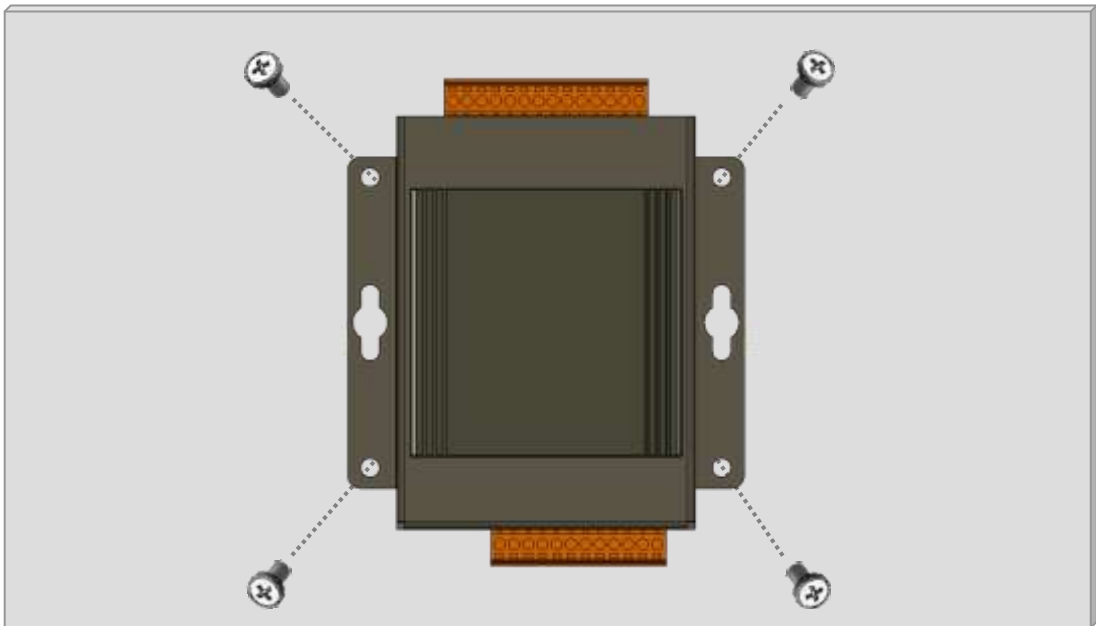

3. Getting Started

The MDCL-700 comes with a default IP address of 192.168.255.1; therefore, a valid IP address should be assigned for the module to join your network. Then you can configure the MDCL module from its web user interface.

The factory default settings

IP Address	Subnet Mask	Gateway
192.168.255.1	255.255.0.0	192.168.0.1

STEP 1: Connect the MDCL module to the same network as your computer and power on all the devices. You can also connect the module to PC directly with an Ethernet cable.

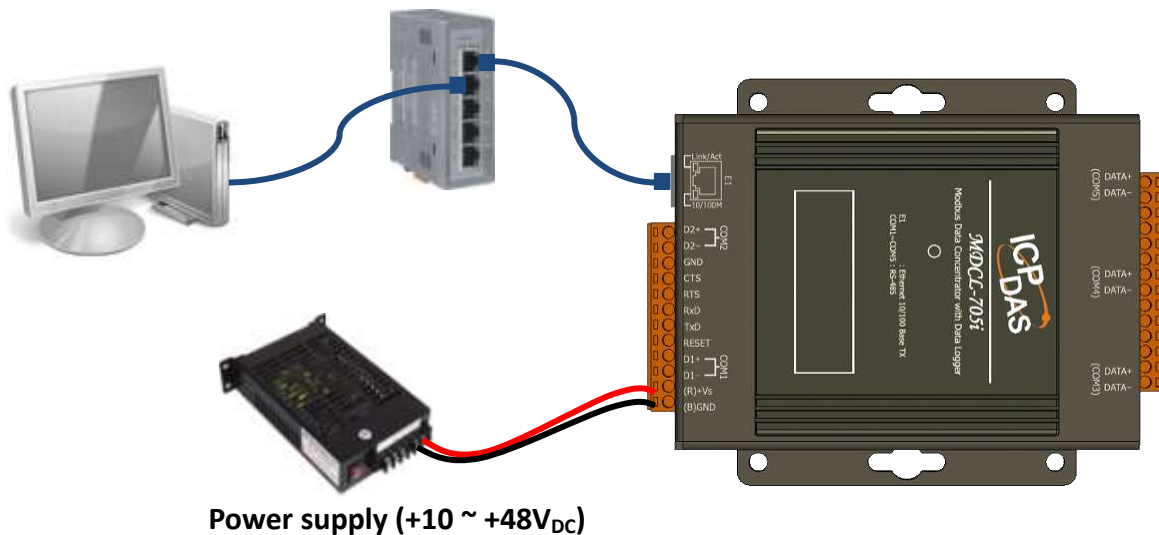

STEP 2: Set the IP configuration on your computer.

If the MDCL module is new with using the default IP address of 192.168.255.1, your pc should pick up an IP address in the range of 192.168.255.2 to 192.168.255.253 that is not in use.

NOTE: Details on how to change the IP address on your computer depend upon the type architecture and operating system you are using. Use the Help and Support functionality on your computer and search for "IP Addressing".

STEP 3: Enter the IP address of the module into the web browser. (For example, http://192.168.255.1)



STEP 4: Create your account (for the first time login)

When accessing the MDCL module's web interface for the first time, you will be prompted to create an administrator account and password. Both username and password must be at least four characters long and may include the following characters:

- Alphabet letters (A - Z, a - z; case-sensitive)
- Numbers (0 - 9)
- Special characters: dot (.), dash (-), underscore (_), and at sign (@)

A screenshot of a web form titled "Create Your Account". The form includes a sub-header: "To log in for the first time you will need to create an administrator account." Below this are three input fields labeled "USERNAME", "PASSWORD", and "CONFIRM PASSWORD". At the bottom of the form is a blue button labeled "CREATE ACCOUNT". To the right of the form, a grey box contains four numbered instructions with arrows pointing to the corresponding form elements: 1. Enter your user name (> 4 characters) points to the USERNAME field; 2. Enter your password points to the PASSWORD field; 3. Enter your password again points to the CONFIRM PASSWORD field; 4. Click CREATE ACCOUNT points to the CREATE ACCOUNT button. At the bottom of the form, the text "MDC-705i-DL Ver 1.00.001" is visible.

STEP 5: Enter your username and password to log in to the MDCL module.

Account Created

Use your username and password to access your administrator account.

USERNAME

PASSWORD

LOGIN

MDC-705i-DL Ver 1.00.001

1. Enter your user name
2. Enter your password
3. Click **LOGIN**

STEP 6: Confirm the connection status icon is open on the status bar.



Denotes the connection between the computer and the MDCL module is open.



Denotes the connection between the computer and the MDCL module is failed.

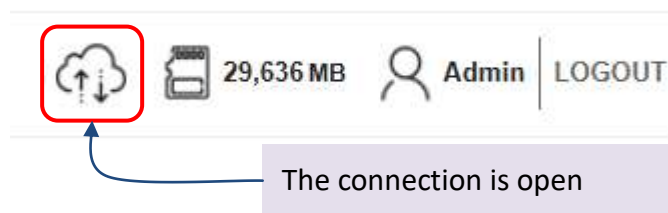

STEP 7: Go to **GENERAL SETTINGS** and select **NETWORK SETTINGS** tab, enter valid IP/Subnet mask and Gateway addresses on the network for your MDCL module. Make sure that the IP address you pick is not currently in use by another device on the network.

Field	Description	Default Setting	Type
IP Address	Enter a valid IP address for the MDCL-705i	192.168.255.1	Required
Subnet Mask	Enter the Subnet Mask address for the module	255.255.0.0	Required
Default Gateway	Enter the Gateway address for the module	192.168.0.1	Required
DNS Server 1	Enter the primary DNS server address (IPv4) If a domain name is set for the NTP server or the FTP server, at least one DNS server should be specified for host name lookups.	-	Optional
DNS Server 2	Enter the secondary DNS server address (IPv4)	-	Optional
HTTP Port	Enter the HTTP port number	80	Required
Modbus TCP Port	Enter the Modbus TCP port number	502	Required

Save new changes

Click **SAVE** to save new changes, a successful message will be displayed, and the MDCL module will automatically restart to apply the new settings.

✓ New settings are properly configured. Please reconnect to this MDCL-705i with the new IP address.

STEP 8: Log in to the MDCL web interface

Restore the IP address on your computer, enter the new IP address for the MDCL module in the web browser and press Enter to open the web interface.

The MDCL web interface is mainly divided into the following parts:

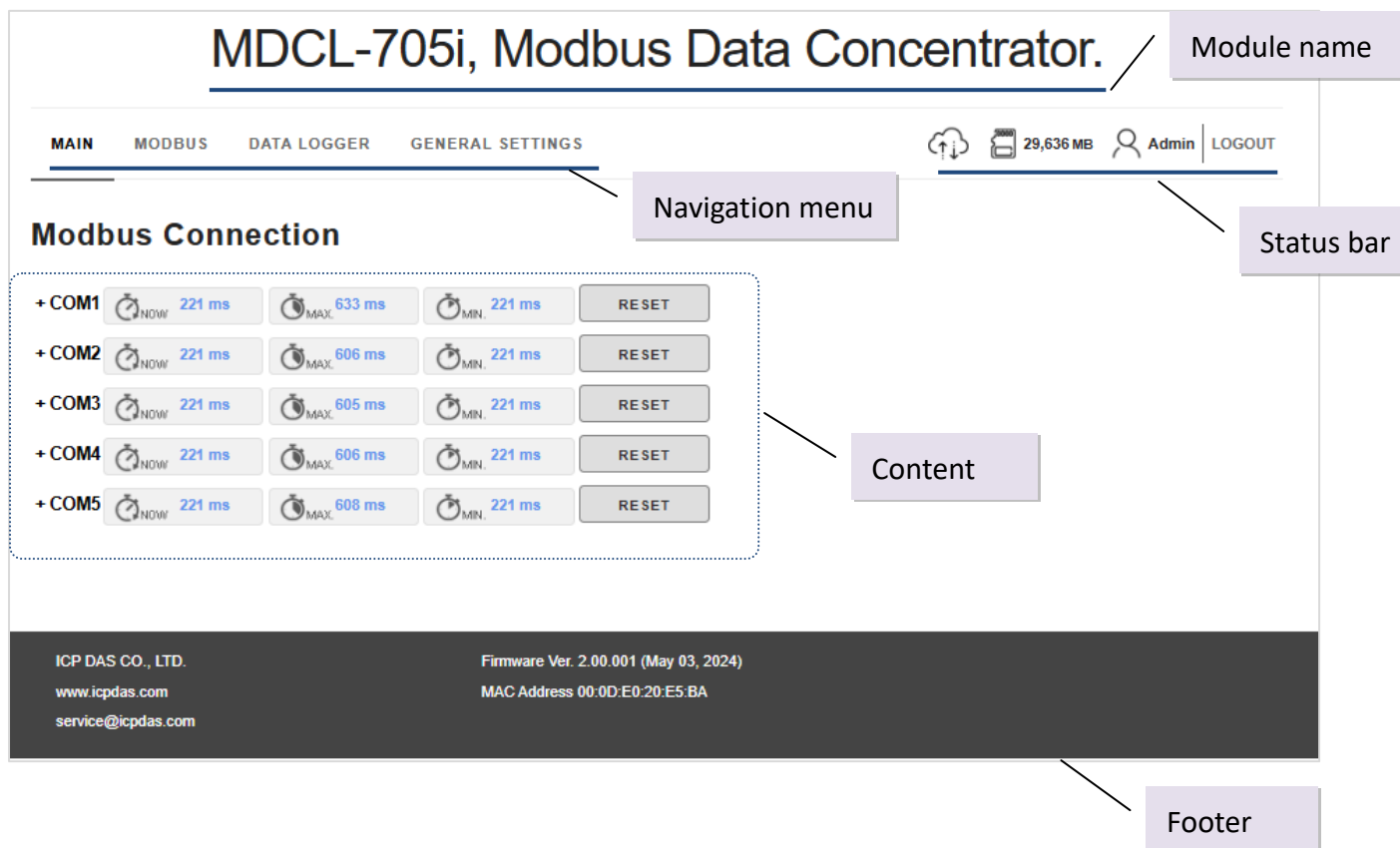

Item	Description
Module name	Displays the MDCL model number
Navigation menu	Houses text links to the section for configuring and managing the module's settings.
Status bar	Contains notification icons and logout icon.
Content	Displays the main operating page related to the functional tab on navigation menu.
Footer	Contains information of ICP DAS web site, firmware version and MAC address.

Reset network settings to factory defaults

The IP/Subnet mask/Gateway modified in a MDCL module can be reset to factory defaults by shorting the RESET pin to GND pin over 3 seconds. The LED display will show “RESET” as below and the IP address set previously will be cleared and returned to the factory default.

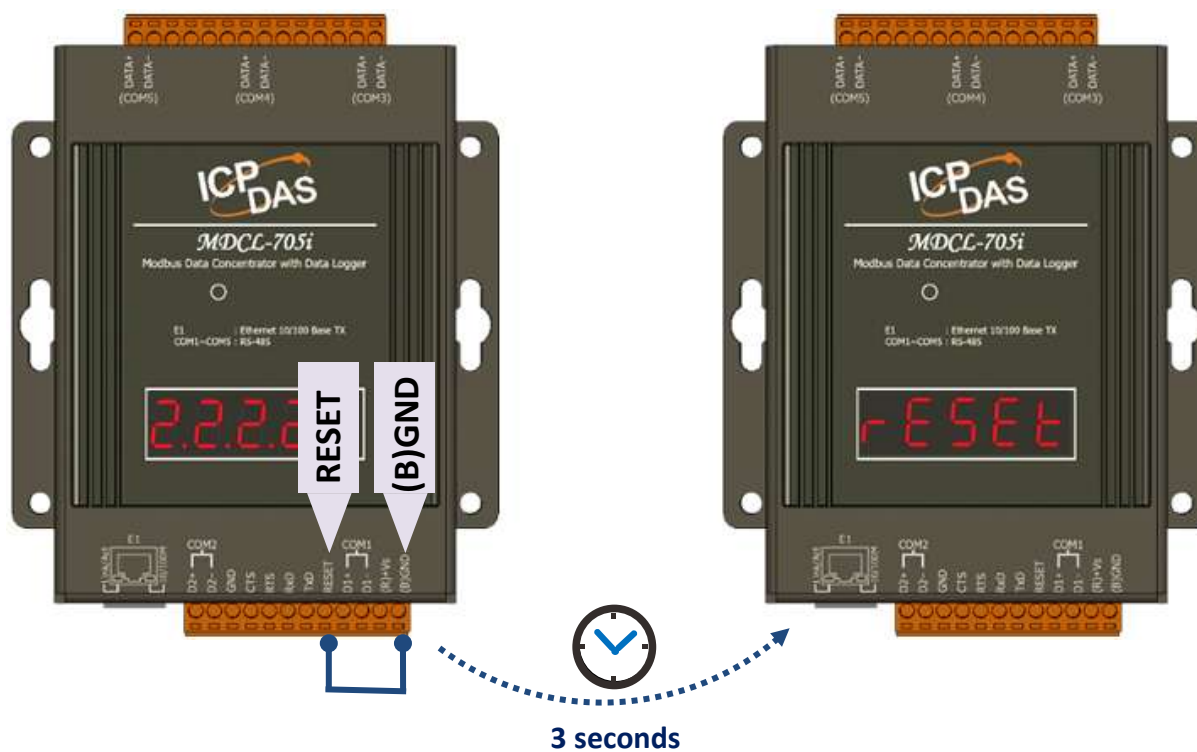

4. System Configuration

4.1. Network Configuration

STEP 1: Go to **GENERAL SETTINGS** page and select the **NETWORK SETTINGS** tab.

STEP 2: Enter valid IP/Subnet mask and Gateway addresses on the network.

STEP 3: Click **SAVE** to save new changes.

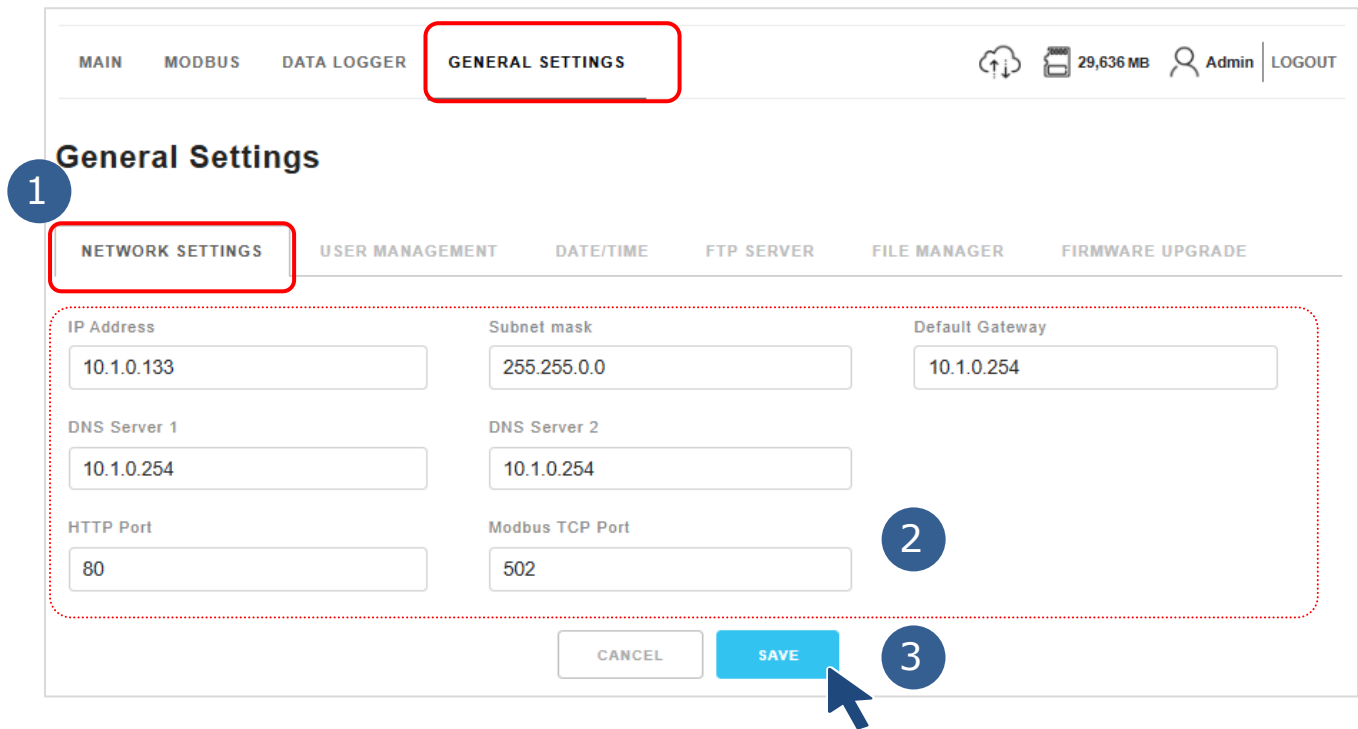

Field	Description	Default setting	Type
IP Address	Enter a valid IP address	192.168.255.1	Required
Subnet Mask	Enter the Subnet Mask address	255.255.0.0	Required
Default Gateway	Enter the Gateway address	192.168.0.1	Required
DNS Server 1	Enter the primary DNS server address (IPv4) If a domain name is set for the NTP server or the FTP server, at least one DNS server should be specified for host name lookups.	-	Optional
DNS Server 2	Enter the secondary DNS server address (IPv4)	-	Optional
HTTP Port	Enter the HTTP port number	80	Required
Modbus TCP Port	Enter the Modbus TCP port number	502	Required

Configuration complete

A green setting completion prompt appears below the field, indicating that the setting is completed.

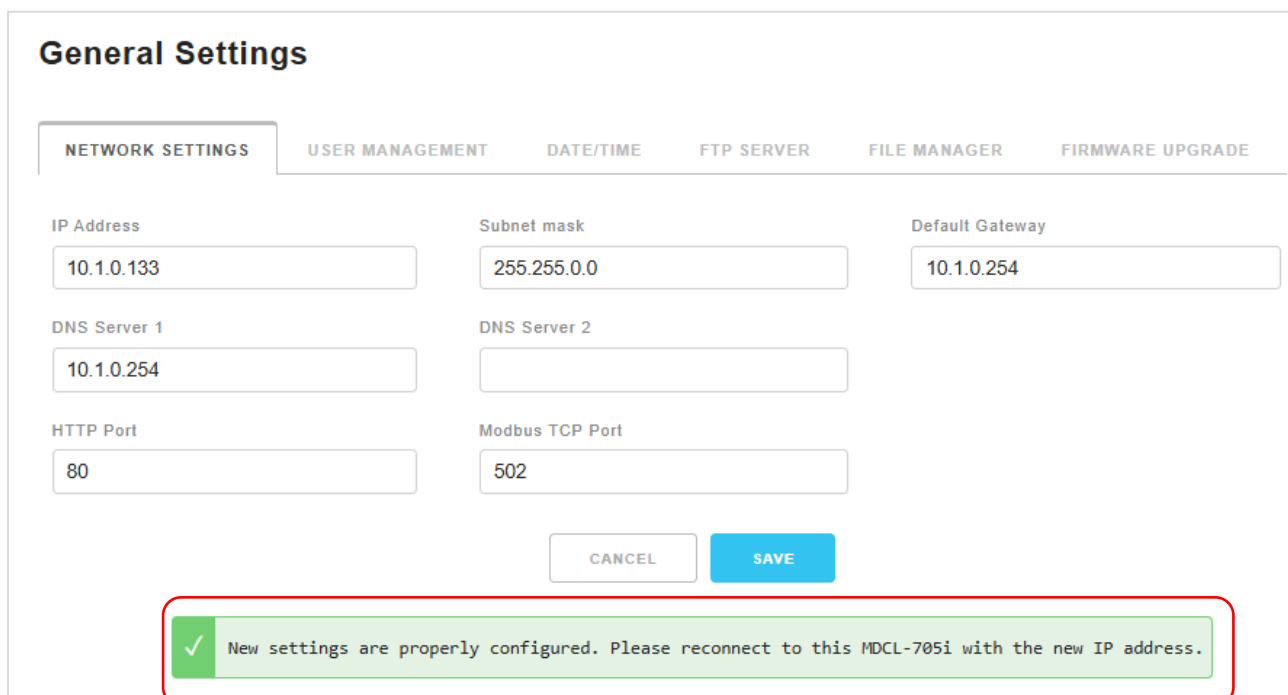

General Settings

NETWORK SETTINGS | USER MANAGEMENT | DATE/TIME | FTP SERVER | FILE MANAGER | FIRMWARE UPGRADE

IP Address: 10.1.0.133 | Subnet mask: 255.255.0.0 | Default Gateway: 10.1.0.254

DNS Server 1: 10.1.0.254 | DNS Server 2:

HTTP Port: 80 | Modbus TCP Port: 502

CANCEL | SAVE

✓ New settings are properly configured. Please reconnect to this MDCL-705i with the new IP address.

Error message

If a red error message appears, the corresponding field will be highlighted with a red border. Please review and correct the highlighted field, then click **SAVE** to complete the configuration.

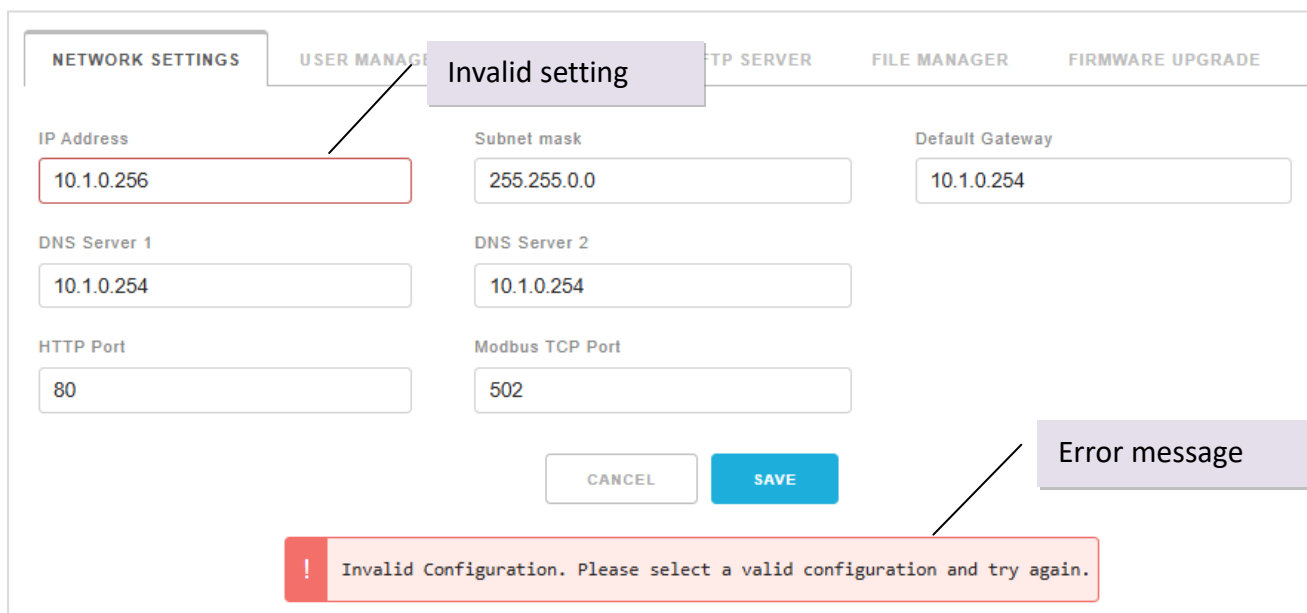

NETWORK SETTINGS | USER MANAGEMENT | DATE/TIME | FTP SERVER | FILE MANAGER | FIRMWARE UPGRADE

Invalid setting

IP Address: 10.1.0.256 | Subnet mask: 255.255.0.0 | Default Gateway: 10.1.0.254

DNS Server 1: 10.1.0.254 | DNS Server 2: 10.1.0.254

HTTP Port: 80 | Modbus TCP Port: 502

CANCEL | SAVE

! Invalid Configuration. Please select a valid configuration and try again.

Error message

4.2. Authentication and Access Control

The authentication and permission-based access control features help prevent unauthorized access or modifications, enhancing the system's security and reliability. The administrator can create a user account with limited read-only access, allowing operators to check device connection statuses without accidentally altering module configurations during operation.

Creating a user account

1. From the navigation bar, select **GENERAL SETTINGS**, then go to the **USER MANAGEMENT** tab.
2. Check the **Active** checkbox and enter your username and password.
3. Click **SAVE** to make the settings take effect. The MDCL will restart and apply the new settings.

The screenshot shows the 'General Settings' page with the 'GENERAL SETTINGS' tab selected in the navigation bar. The 'USER MANAGEMENT' tab is also selected. The 'Active' checkbox for the 'user' role is checked. The 'SAVE' button for the 'user' role is highlighted with a red arrow and a '3' in a blue circle.

Active	Role	Username	Password	
<input type="checkbox"/>	administrator	<input type="text" value="Admin"/>	<input type="text" value="Admin"/>	<input type="button" value="SAVE"/>
<input checked="" type="checkbox"/>	user	<input type="text" value="User"/>	<input type="text" value="User"/>	<input type="button" value="SAVE"/>

The screenshot shows the 'General Settings' page with the 'USER MANAGEMENT' tab selected. The 'Active' checkbox for the 'user' role is checked. A green message box at the bottom says 'New settings are properly configured.' A callout box labeled 'Successful message' points to the message box.

Active	Role	Username	Password	
<input type="checkbox"/>	administrator	<input type="text" value="Admin"/>	<input type="text" value="Admin"/>	<input type="button" value="SAVE"/>
<input checked="" type="checkbox"/>	user	<input type="text" value="User"/>	<input type="text" value="User"/>	<input type="button" value="SAVE"/>

✓ New settings are properly configured.

Successful message

General Settings

NETWORK SETTINGS **USER MANAGEMENT** DATE/TIME FTP SERVER FILE MANAGER FIRMWARE UPGRADE

Active	Role	Username	Password	
	administrator	<input type="text" value="Admin"/>	<input type="text" value="Admin"/>	<input type="button" value="SAVE"/>
<input checked="" type="checkbox"/>	user	<input type="text" value="User"/>	<input type="text"/>	<input type="button" value="SAVE"/>

! Invalid Configuration. Please select a valid configuration and try again.

Invalid setting: The password field cannot be left blank.

Logging in with the user account

When logged in with the user account, the username will be displayed in the status bar.

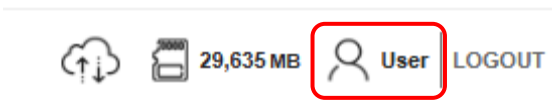

Module settings accessible to the user account

Page	Access Permissions
Main	View connection status of polling definitions and the scan time of each COM port.
Modbus	View configuration of each COM port and its polling definitions.
Data Logger	View recorder settings and data logging configurations.
General Settings	View MDCL settings including IP, DNS server, port number, system time, and FTP.

4.3. Date and Time

System Time, Time Zone and Network Time Server can be set on **GENERAL SETTINGS > DATE/TIME** page

The screenshot shows the 'DATE/TIME' configuration page. At the top, there are navigation tabs: NETWORK SETTINGS, USER MANAGEMENT, DATE/TIME (highlighted with a red box), FTP SERVER, FILE MANAGER, and FIRMWARE UPGRADE. The main content area includes: 'Current System Time' with a text box showing '6/10/2025, 5:14:39 PM' and a 'SYNC WITH PC'S CLOCK' button; 'Time Zone' with a dropdown menu set to '(UTC+08:00)'; 'Network Time Server 1' with a text box containing 'pool.ntp.org'; 'Network Time Server 2' with a text box containing 'time.windows.com' and a 'SYNC NOW' button; a checkbox labeled 'Force synchronize every' which is checked, followed by a dropdown menu set to '12 hours'; and at the bottom, 'CANCEL' and 'SAVE' buttons.

System time

- **Current System Time:** displays the current system time on your MDCL-705i. The date and time information is used for accurate timestamps in a log file.
- **SYNC WITH PC'S CLOCK:** click the button to synchronize the system time with the PC's clock.

Time zone

- Select the time zone from the Time Zone dropdown menu.

Clock synchronization over network

- **Network Time Server 1:** Enter the IP address or hostname of an NTP server (Optional)
If a domain name is used, you need to specify the DNS server in the NETWORK SETTINGS page.
- **Network Time Server 2:** Enter the IP address or hostname of a redundant NTP server if needed. (Optional)
- **SYNC Now:** Click **SYNC NOW** to synchronize the system clock with NTP servers immediately.
- **Auto time correction:** tick on the checkbox of **Force synchronize** and select the update interval for time synchronization scheduler on the drop down menu.

This close-up shows the 'Force synchronize every' checkbox checked. The dropdown menu is open, showing options: 24 hours (selected), 4 hours, 12 hours, and 24 hours. To the right are 'CANCEL' and 'SAVE' buttons.

Save new changes

Click **SAVE** to apply the new changes. A pop-up message will appear, prompting the user to choose whether to restart the module now or later.

- **Restart Now:** immediately restarts the modules to apply the changes.
- **Restart Later:** postpones the restart; the changes will take effect after the modules are restarted.

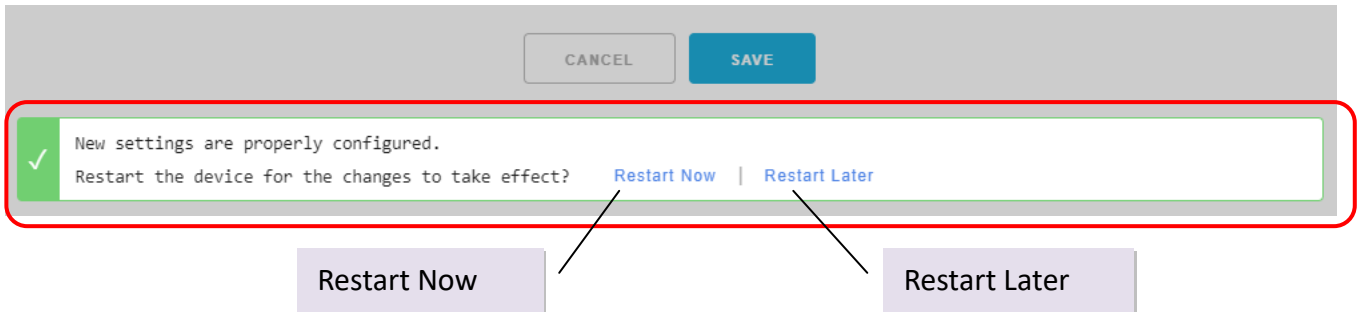

Restart Later

If you click Restart Later, a RESTART icon will appear in the status bar, allowing you to restart the module at a later time. You can restart the module once all your settings have been completed..

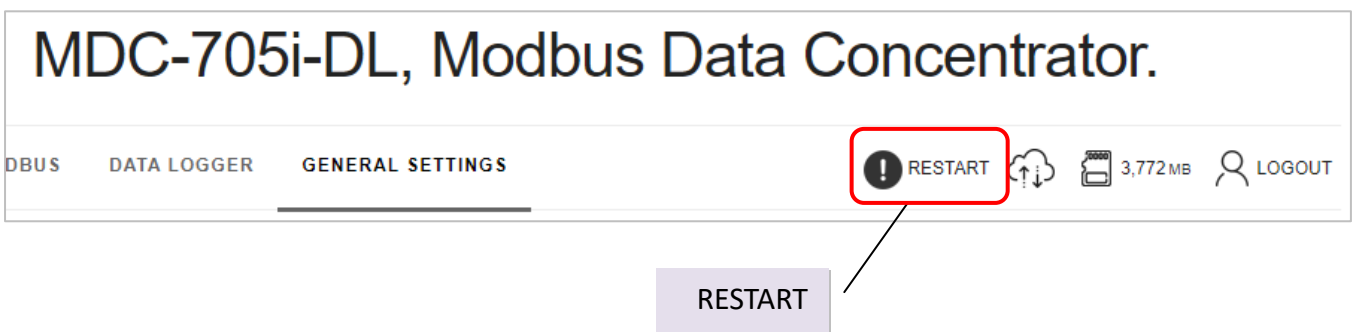

Time synchronization error

If an error message appears when clicking the **SYNC NOW** button, refer to the message content and correct the problematic settings.

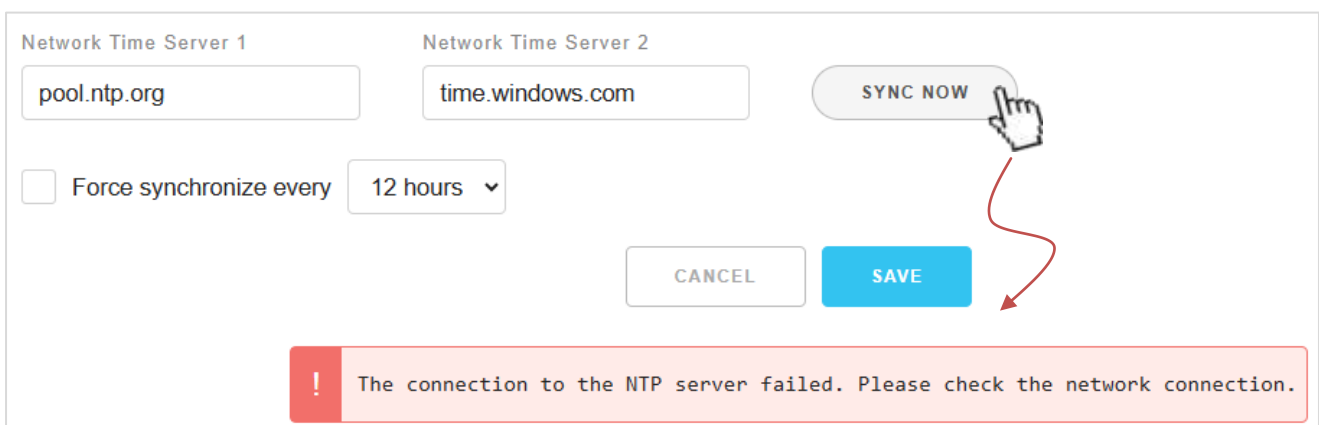

4.4. FTP Server Configuration

On the **GENERAL SETTINGS > FTP SERVER** page, you can configure a remote FTP server, including the directory where the log files will be updated after they are closed. This allows field data to be efficiently and accurately transferred to the analysis system without manual intervention.

The screenshot shows the 'FTP SERVER' configuration page. At the top, there are navigation tabs: MAIN, MODBUS, DATA LOGGER, GENERAL SETTINGS (selected), FILE MANAGER, and FIRMWARE UPGRADE. The 'FTP SERVER' tab is highlighted with a red box. Below the tabs, there are several input fields:

- FTP Server Name:** A text box containing 'FTP_SERVER'.
- FTP Server:** A text box containing '192.168.255.100'.
- FTP Control Port:** A text box containing '21'.
- Login User Name:** An empty text box.
- Password:** An empty text box with a note: '(Leave blank to disable password access)'.
- Directory Path:** A text box containing '/log'.

 At the bottom, there are two buttons: 'CANCEL' and 'SAVE'.

FTP server configuration

Field	Description	Default	Type
FTP Server Name	Enter the name of the FTP server.	FTP_Server	Required
FTP Server	Enter the FTP server's IP address or domain name. If a domain name is used, a DNS server must be specified in NETWORK SETTINGS.	192.168.255.100	Required
FTP Control Port	Enter the FTP control port number.	21	Required
Login User Name	Enter the FTP server login username. Leave blank if login is not required.	-	Optional
Password	Enter the FTP server login password. Leave blank if login is not required.	-	Optional
Directory Path	Enter the target directory path for uploading log files to the FTP server. An individual directory path may be set for each module to update its own log files.	/log	Required

Save new changes

Click **SAVE** to save new changes, the MDCL will prompt whether to restart the module.

- **Restart Now:** restart the modules immediately to take the changes in effect.
- **Restart Later:** restart the modules later to apply all changes after completing other settings.

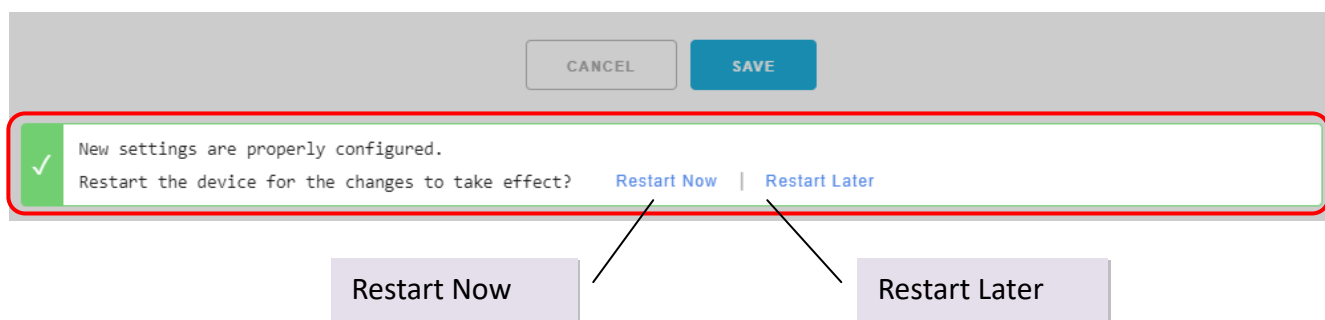

Restart Later

If you choose Restart Later, a RESTART icon will appear on the top-right status bar. Once all configurations are complete, click RESTART to apply the changes by restarting the module.

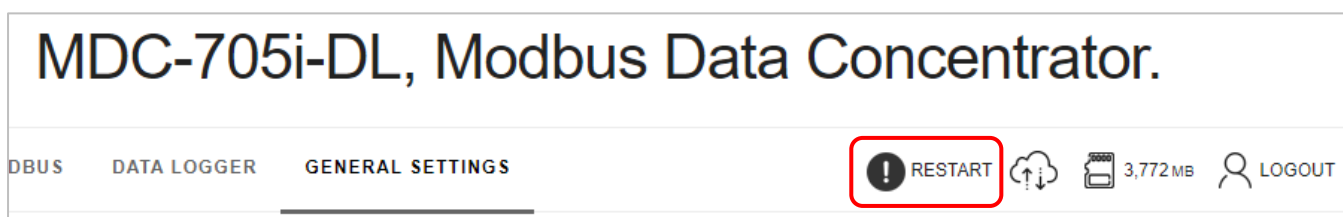

4.5. Log File Manager

From the **GENERAL SETTINGS > FILE MANAGER** page, you can search log files by date, and download or delete them by clicking on the corresponding icons in the log file list.

General Settings

NETWORK SETTINGS USER MANAGEMENT DATE/TIME FTP SERVER **FILE MANAGER** FIRMWARE UPGRADE

yyyy-mm-dd SEARCH 

Date Created	Name	Size
--------------	------	------

Specify a record created date for the search

- Enter Date in the format yyyy-mm-dd, or

SEARCH 

- Click the calendar icon to select the date of the log files that you would like to search. Take 2025/06/10 as an example:

SEARCH 

Select a month

Su	Mo	Tu	We	Th	Fr	Sa
1	2	3	4	5	6	7
8	9	10	11	12	13	14
15	16	17	18	19	20	21
22	23	24	25	26	27	28
29	30	1	2	3	4	5

Select a date

Search log files

- Confirm the date for search and then click **SEARCH**, the search result will be displayed on the page (as the chart below shows).

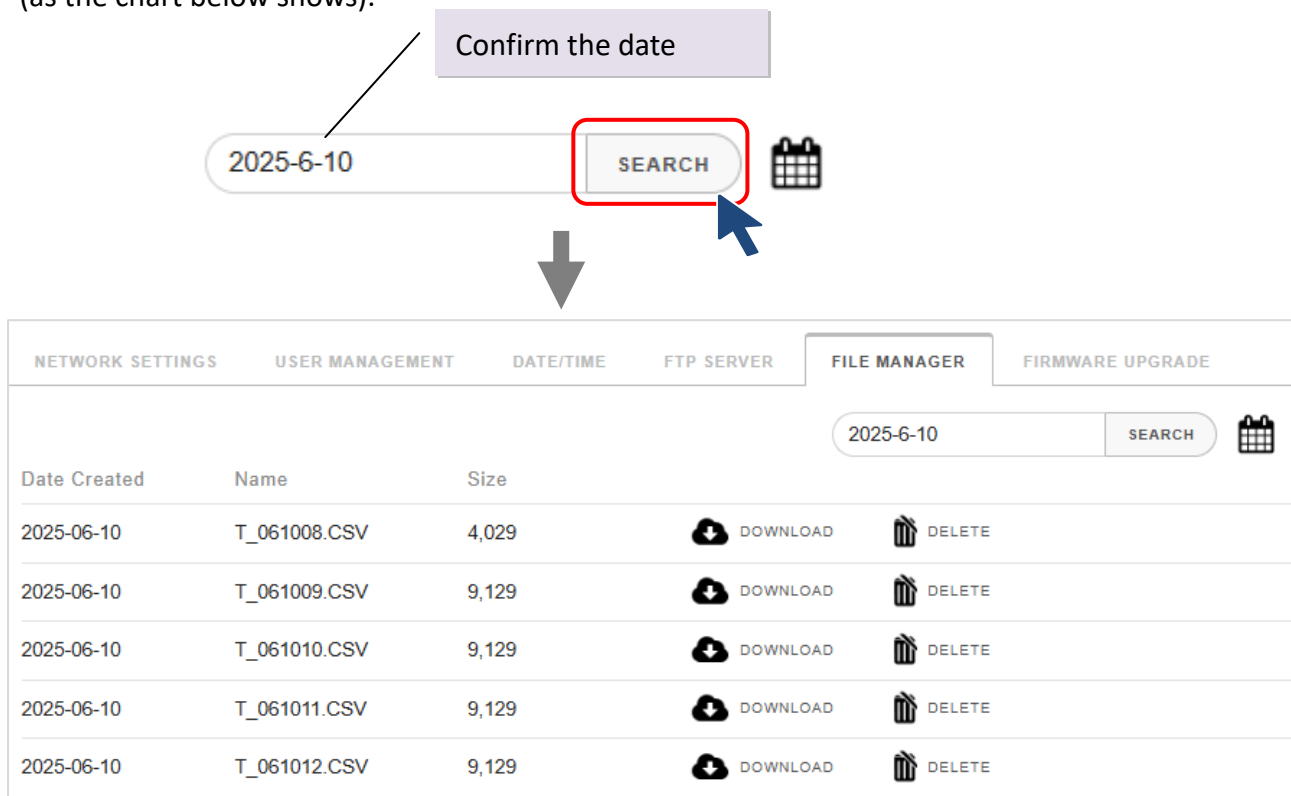

Confirm the date

2025-6-10 SEARCH

NETWORK SETTINGS	USER MANAGEMENT	DATE/TIME	FTP SERVER	FILE MANAGER	FIRMWARE UPGRADE
2025-6-10 SEARCH					
Date Created	Name	Size			
2025-06-10	T_061008.CSV	4,029	DOWNLOAD	DELETE	
2025-06-10	T_061009.CSV	9,129	DOWNLOAD	DELETE	
2025-06-10	T_061010.CSV	9,129	DOWNLOAD	DELETE	
2025-06-10	T_061011.CSV	9,129	DOWNLOAD	DELETE	
2025-06-10	T_061012.CSV	9,129	DOWNLOAD	DELETE	

Download file

- Click the **DOWNLOAD** icon for a file to download it to the default download directory of web browser. Downloading the data does not delete it from the MDCL.

Date Created	Name	Size		
2025-06-10	T_061008.CSV	4,029	DOWNLOAD	DELETE

Delete file

- Click the **DELETE** icon for a file, and then click the **DELETE** button in the confirmation message.

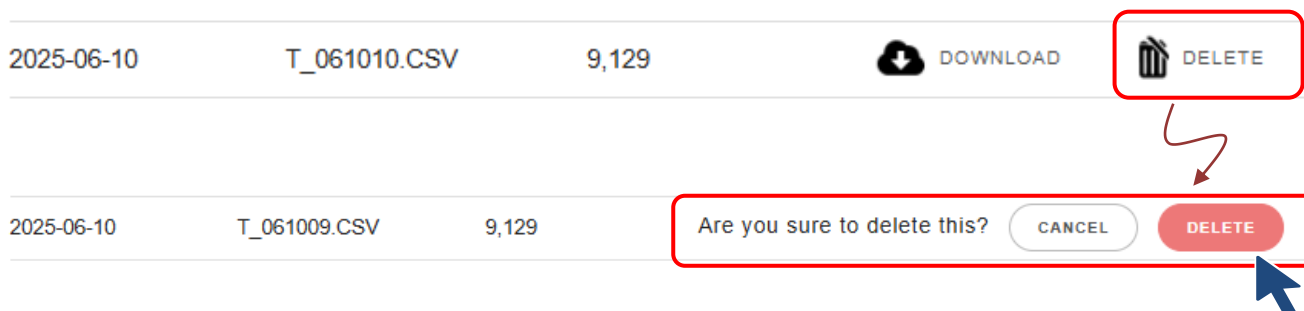

2025-06-10	T_061010.CSV	9,129	DOWNLOAD	DELETE
------------	--------------	-------	----------	--------

Are you sure to delete this? CANCEL DELETE

4.6. Firmware Update

Starting from firmware version 2.00.001, you can update the firmware through the MDCL module's web interface. Go to the FIRMWARE UPGRADE page under GENERAL SETTINGS to check the current firmware version and perform the update.

Firmware Update Procedure

- Click **BROWSE** to select the firmware file you want to upload.
- Click the **UPLOAD** button to complete the firmware update.

General Settings

NETWORK SETTINGS USER MANAGEMENT DATE/TIME FTP SERVER FILE MANAGER **FIRMWARE UPGRADE**

Module Name MDCL-705i V2

Current Firmware Version 2.00.001

Date May 03, 2024

 BROWSE **2** **UPLOAD**

1

5. Modbus Configuration

5.1. COM Port Configuration

The COM port configuration is used to configure the parameters for Modbus communication connection between MDCL and Modbus RTU slave devices. The configuration interface is provided on **MODBUS** page.

STEP 1: Select **MODBUS** from the navigation menu, and scroll down to the COM port section.

STEP 2: Click on the COM port tab.

STEP 3: Configure the communication parameters for each port.

STEP 4: Click **SAVE** to save the new changes.

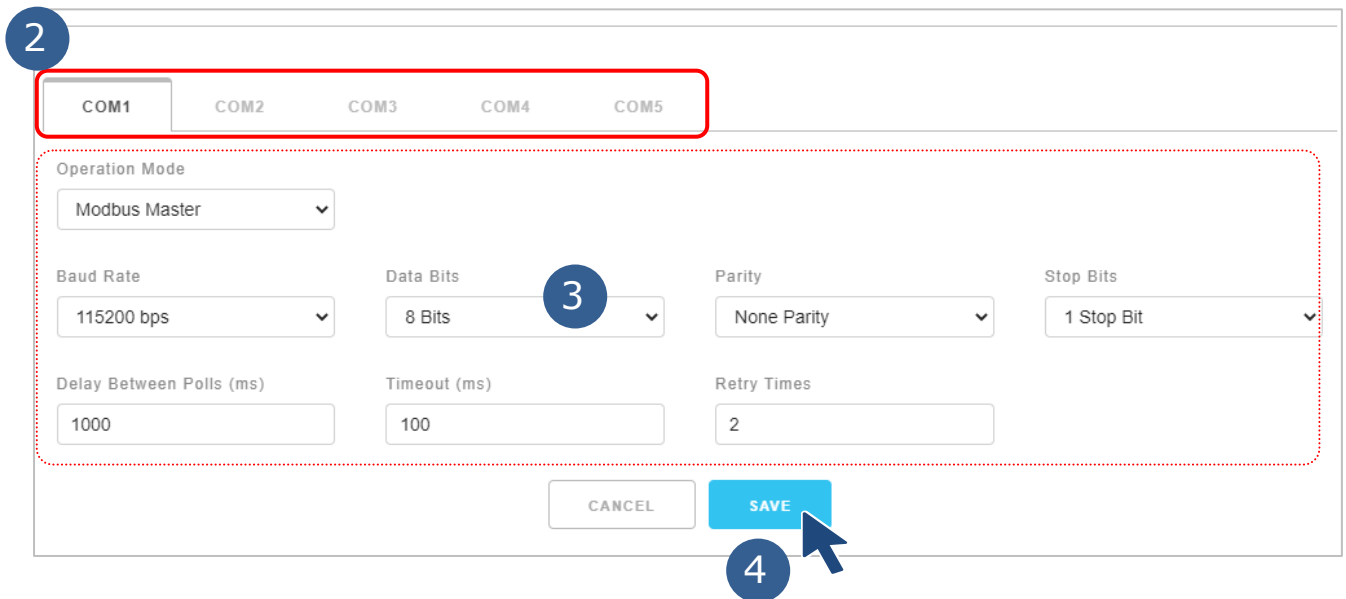
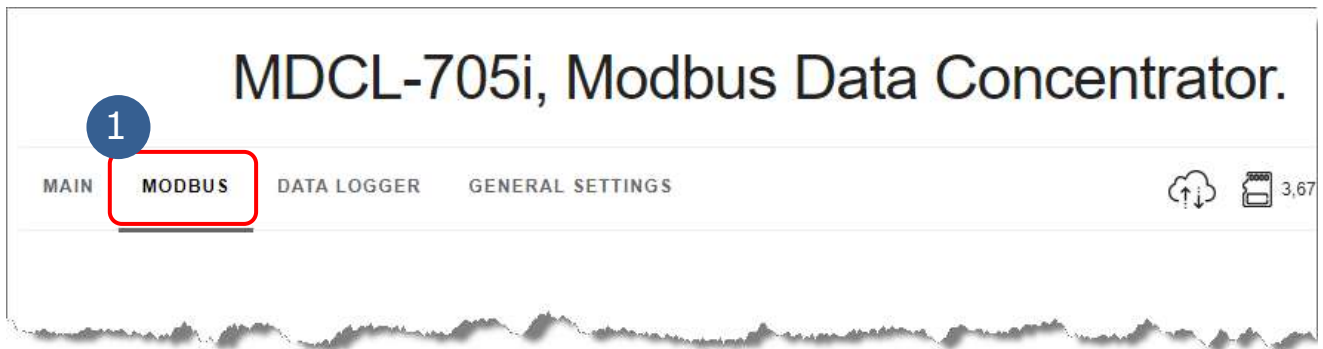

Items	Description	Type
Operation Mode	<ul style="list-style-type: none"> Modbus Master: this mode is used to connect Modbus RTU slave devices. MDCL is acting as a master to send requests to slaves Modbus Slave: this mode is used to connect Modbus RTU master; it allows the master to read/write data from/to the MDCL. 	Required
Baud Rate	Defines the transmission speed between the MDCL and the RTU devices. The BaudRate can be set to 1200/ 2400/ 4800/ 9600/ 19200/ 34800/ 57600/ 115200 (bps) depending on the RTU device(s) being used.	Required
Data Bits	Defines the number of data bits in each character. It is fixed to 8 and the RTU devices need be set to 8-bit data, too.	Required
Parity	Defines the Parity bit. The parity bit can be set to None Parity, Even Parity or Odd Parity.	Required
Stop Bits	Defines the Stop bits. Only 1 Stop Bit can be used.	Required
Delay Between Polls(ms)	Defines the Poll Delay between each scan for Modbus RTU communication. Default value: 100 ms. Available range: 20 to 6000 (ms).	Required
Timeout(ms)	Defines the period of time that the MDCL module will wait for a response from a RTU slave device. A timeout is occurred if the MDCL module does not receive the response within the specified time period, and then the MDCL will resend the same command continuously until the number of timeout errors equals to the value set in parameter Retry Times . Default value: 120 ms. Available range: 50 to 6000 ms.	Required
Retry Times	Defines the number of consecutive timeout errors are allowed for a command. If the count of timeout errors equals to the value set in Retry Times , the device will be determined to be disconnected. During the disconnection period, the MDCL will try to establish communication with the device every 10 seconds instead of executing this command in polling process, until it receives a correct response from the device. Default value: 2. Available range: 1 to 20.	Required

Save new changes

Click **SAVE** to save new changes, the MDCL will prompt whether to restart the module.

- **Restart Now:** restart the modules immediately to take the changes in effect
- **Restart Later:** restart the modules later to apply all changes after completing other settings.



Restart later

If you choose Restart Later, a **RESTART** icon will appear on the top-right status bar. Once all configurations are complete, click this icon to apply the changes by restarting the module.

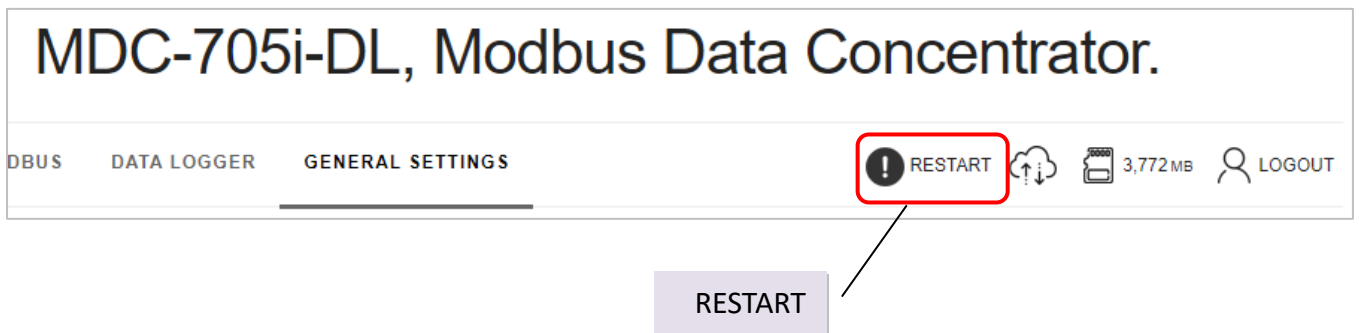

6. MDC Configuration (config.csv)

6.1. Exporting/Importing the Config.csv File

The MDC function in the MDCL-705i module can concentrate data from several Modbus RTU slave devices through standard RS-485 interfaces, and allows Modbus TCP masters to read/write data via Ethernet/LAN. The Modbus master can use one Modbus command to get all data with the same type from various Modbus RTU slave devices, and change the status of a channel by writing command to the register assigned for the channel in the MDCL module.

Modbus RTU polling definition in config.csv is used to define Modbus RTU commands for reading data from the slave devices. The Comma Separated Values (CSV) files can be viewed and edited in spreadsheet applications like Microsoft Excel, or in any text editor, in which the comma character (,) typically separates each field of text.

	A	B	C	D	E	F	G	H	I	J
1	#	UseComPort	SlaveModbusID	FunctionCode	RegStartAddr	RegCount	TimeoutEventProcess	PresetValue	GroupName	Description
2	*	1	5	1	0	8	2	10000	M_7018_1	temperature_1
3	*	1	5	1	0	8	2	10000	M_7018_2	temperature_2
4	*	2	4	2	0	4	2	10001	M_7017_1	Motor_1
5	*	2	4	2	0	4	2	10001	M_7017_2	Motor_2
6	*	3	3	3	2	3	0	10002	Device_3	Device_3__
7	*	3	3	3	2	3	0	10002	Device_4	Device_4__
8	*	4	2	4	2	3	0	10002	Device_5	Device_5__
9	*	4	2	4	2	3	0	10002	Device_6	Device_6__
10	*	5	1	1	2	3	0	10002	Device_7	Device_7__
11	*	5	1	1	2	3	0	10002	Device_8	Device_8__

The file name **config.csv** cannot be changed, and the name and order of parameters in each line for a polling definition cannot be changed, too. To avoid errors caused by manual editing, you can export the config.csv file from **Modbus** page and modify it to meet your requirements.

Export the config.csv

STEP 1: Click **EXPORT** on Modbus page.

STEP 2: Obtain the file from the download directory configured in the web browser.

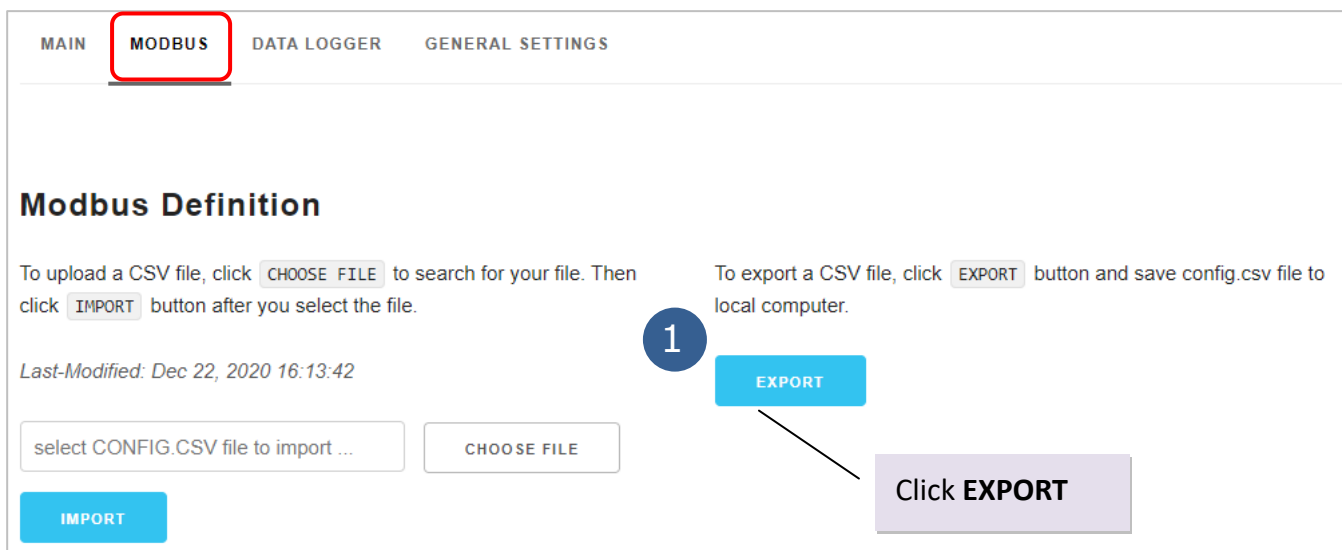

The screenshot shows the 'Modbus Definition' page with a navigation bar containing 'MAIN', 'MODBUS', 'DATA LOGGER', and 'GENERAL SETTINGS'. The 'MODBUS' tab is highlighted with a red box. Below the navigation bar, the page title 'Modbus Definition' is followed by instructions: 'To upload a CSV file, click CHOOSE FILE to search for your file. Then click IMPORT button after you select the file.' and 'To export a CSV file, click EXPORT button and save config.csv file to local computer.' A 'Last-Modified: Dec 22, 2020 16:13:42' timestamp is present. The interface includes a text input 'select CONFIG.CSV file to import ...', a 'CHOOSE FILE' button, and an 'IMPORT' button. A blue 'EXPORT' button is highlighted with a red circle containing the number '1'. A callout box with the text 'Click EXPORT' and an arrow points to the 'EXPORT' button.

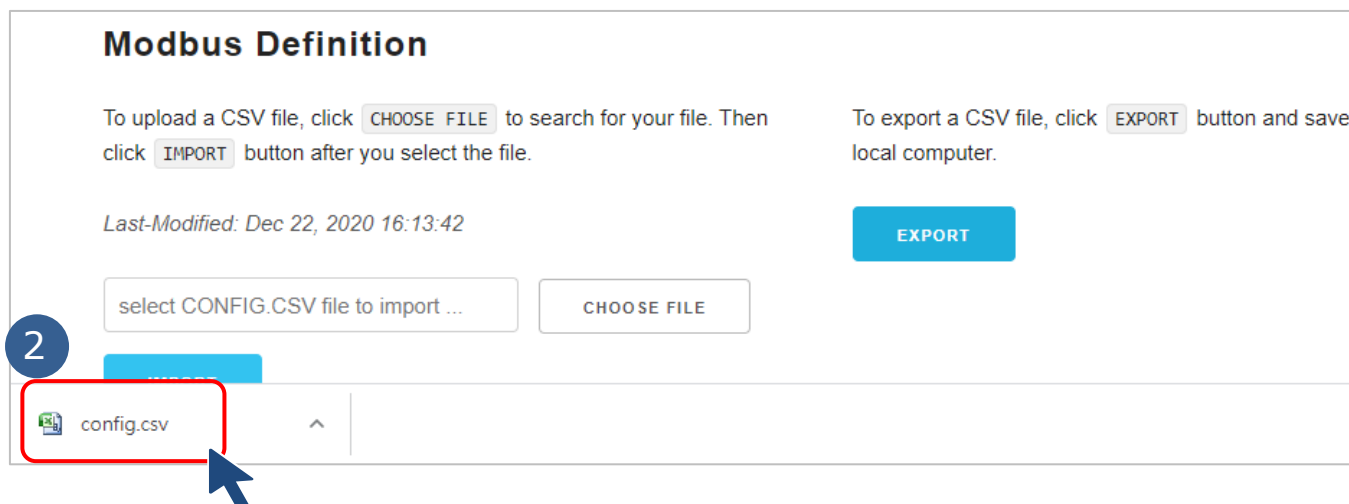

The screenshot shows the 'Modbus Definition' page with the same instructions as the previous screenshot. The 'EXPORT' button is highlighted with a red circle containing the number '2'. Below the page content, the browser's download bar is visible, showing a file named 'config.csv' with a red box around it and a mouse cursor pointing to it.

Import the config.csv

STEP 1: Click **CHOOSE FILE** on MODBUS page and then select your config.csv file.

STEP 2: Click **IMPORT**.

The screenshot shows the 'MODBUS' tab in a web interface. The 'Modbus Definition' section contains instructions: 'To upload a CSV file, click **CHOOSE FILE** to search for your file. Then click **IMPORT** button after you select the file.' and 'To export a CSV file, click **EXPORT** button and save config.csv file to local computer.' Below the text, there is a text input field with the placeholder 'select CONFIG.CSV file to import ...', a 'CHOOSE FILE' button, and an 'IMPORT' button. A blue arrow points to the 'IMPORT' button, labeled with a '2'. A callout box labeled '1' points to the 'CHOOSE FILE' button with the text 'Click **CHOOSE FILE**'. An 'EXPORT' button is also visible. The top navigation bar includes 'MAIN', 'MODBUS', 'DATA LOGGER', and 'GENERAL SETTINGS', with 'MODBUS' highlighted in a red box. The 'Last-Modified' timestamp is 'Dec 22, 2020 16:13:42'.

MDCL will validate the imported file and present the result as success or error message with line and position information of invalid parameters as shown below. A definition with invalid parameters will not be executed in polling process.

Success message

A green-bordered box with a checkmark icon on the left. The text inside reads: 'File upload successful.' followed by 'File validation completed successfully.'

Error message

A red-bordered box with an exclamation mark icon on the left. The text inside reads: 'File upload successful.' followed by 'Your CSV file contains 2 error(s). Please correct and import again.' Below this, two error messages are listed: 'Invalid value for field 'UseComPort' in line 2:' followed by 'Line 2: * , 0 , 4 , 0 , 5 , 1 , 0 , 103_01 , ReadR Data L' and 'Invalid value for field 'FunctionCode' in line 3:' followed by 'Line 3: * , 1 , 1 , 5 , 452 , 1 , 2 , 0 , 103_02 , ReadR Offset L'. Two callout boxes point to the errors: one points to the '0' in line 2 with the text 'Invalid value: COM port starts from 1' and another points to the '5' in line 3 with the text 'Invalid value: Function code 5 is not supported'.

6.2. Configuring polling definition

Before start to configure the parameters for the Polling Definition, be sure to check the COM port number that the target device is connected to, the Modbus ID for every Modbus RTU device, function code, start address, and the quantity for reading data. Up to 250 Modbus RTU commands can be performed in a MDCL-700 module, and up to 9600 registers for each of AI, AO, DI, and DO type data can be used.

	A	B	C	D	E	F	G	H	I	J
1	#	UseComPort	SlaveModbusID	FunctionCode	RegStartAddr	RegCount	TimeoutEventProcess	PresetValue	GroupName	Description
2	*	1	5	1	0	8	2	10000	M_7018_1	temperature_1
3	*	1	5	1	0	8	2	10000	M_7018_2	temperature_2
4	*	2	4	2	0	4	2	10001	M_7017_1	Motor_1
5	*	2	4	2	0	4	2	10001	M_7017_2	Motor_2
6	*	3	3	3	2	3	0	10002	Device_3	Device_3__
7	*	3	3	3	2	3	0	10002	Device_4	Device_4__
8	*	4	2	4	2	3	0	10002	Device_5	Device_5__
9	*	4	2	4	2	3	0	10002	Device_6	Device_6__
10	*	5	1	1	2	3	0	10002	Device_7	Device_7__
11	*	5	1	1	2	3	0	10002	Device_8	Device_8__

Each Polling Definition consists of 10 parameters listed as below:

Item	Description
#	Specifies the type for a polling definition: “*” (Asterisk): indicates an active polling definition. The MDCL will assign local registers for the defined data, actively poll and store the data in those registers. “-” (Minus): indicates a disabled polling definition. The MDCL will assign local registers for the defined data but will not poll it. This is useful when certain devices are inactive in specific scenarios. Retaining the assigned register addresses helps with the management and maintenance of similar projects that use different devices. “ ” (Blank): indicates a null polling definition. The MDCL will neither assign local registers nor poll data. This option is suitable for keeping a record of previously used definitions.
UseComPort	Specifies the COM port number to which the slave device is connected. The port number ranges from 1 up to the total number of COM ports available on the MDCL.
SlaveModbusID	Specifies the slave device ID. The valid range is from 1 to 255.
FunctionCode	Specifies the Modbus function code. Depending on the I/O features of the slave device, valid codes include: 1 (Read DO), 2 (Read DI), 3 (Read AO) or 4 (Read AI).
RegStartAddr	Specifies the starting address of the first register to be read. The valid range is 0 to 65535.
RegCount	Specifies the number of registers to be read. The valid range is 1 to 125.

Timeout EventProcess	Specifies the action to take when a timeout error occurs during polling: 0: return the exception code (Mode 1) 1: return the most recent data received before the timeout (Mode 2) 2: return a preset value (Mode 3)
PresetValue	Specifies the preset value to be used when TimeoutEventProcess is set to 2. The valid range is from 0 to 65535.
GroupName (*4)	Each polling definition must have a unique GroupName, which is required for data logging configuration. If two or more polling definitions share the same GroupName, the MDCL will be unable to log the data associated with them. 1 to 12 ASCII characters are available.
Description (*4)	A comment or description for the polling definition. This information will be displayed in the web interface to help users better understand the definition. 1 to 16 ASCII characters are available.

NOTE:

- *1. The maximum number of all the polling definitions is 250.
- *2. The MDCL provides 9600 internal Modbus registers for each table (DI/DO/AI/AO) to hold data collected from the RTU slave devices.
- *3. In order to retain register space mapped for specific devices; or to release those spaces mapped but reserve the definition for changed or stopped devices with a minimum level of modification, users just need to set different types for a polling definition in different applications.
- *4. The characters "-", "*", "~" and "#" are reserved and cannot be used in text field including the **GroupName** and **Description** fields

6.3. Verifying Polling Definitions

Once the config.csv file is imported, the polling definitions for each COM port will be listed below the configuration section. You can select each COM port tab to review the imported polling parameters in the MDCL module.

STEP 1: On the MODBUS page, click the relevant tab to select the COM port.

STEP 2: Review the polling parameters to ensure they were configured correctly.

The screenshot displays the MODBUS configuration page. At the top, there are navigation tabs: MAIN, MODBUS (highlighted with a red box), DATA LOGGER, and GENERAL SETTINGS. On the right, there are icons for refresh, storage (3,772 MB), and a user profile with a LOGOUT button. Below the navigation, there are tabs for COM1 (highlighted with a red box), COM2, COM3, COM4, and COM5. The main configuration area includes several dropdown menus and input fields: Operation Mode (Modbus Master), Baud Rate (115200 bps), Data Bits (8 Bits), Parity (None Parity), Stop Bits (1 Stop Bit), Delay Between Polls (ms) (80), Timeout (ms) (200), and Retry Times (20). Below these settings, there are buttons for 'RELOAD' and 'CANCEL'. A callout box points to the 'RELOAD' button with the text 'Reload list'. Another callout box points to the '10' items per page dropdown with the text 'Select how many items per page'. Below the buttons is a table of Modbus RTU polling definitions. A callout box points to the table with the text 'Modbus RTU polling definition list'.

#	Active	COM Port	Modbus Slave ID	Function Code	Modbus Address	Quantity	Timeout Exception	Preset Value	Group Name	Description
1	Enable	COM1	1	FC03	0	1	Mode3	0	COM1.0000	COM1.01.FC03.000
2	Enable	COM1	1	FC03	1	2	Mode3	0	COM1.0001	COM1.01.FC03.001
3	Enable	COM1	1	FC03	3	4	Mode3	0	COM1.0002	COM1.01.FC03.003
4	Enable	COM1	1	FC03	7	8	Mode3	0	COM1.0003	COM1.01.FC03.007
5	Enable	COM1	1	FC03	15	16	Mode3	0	COM1.0004	COM1.01.FC03.015
6	Enable	COM1	1	FC03	31	32	Mode3	0	COM1.0005	COM1.01.FC03.031

6.4. Application

Environmental monitoring in a community library

To monitor indoor air quality - including temperature, humidity, CO, CO₂, and PM2.5 levels - in a community library with multiple areas (lobby, journal room, reading room, multimedia center, and stack room), one MDCL-705i and five CL-213 modules are used and deployed as shown below.

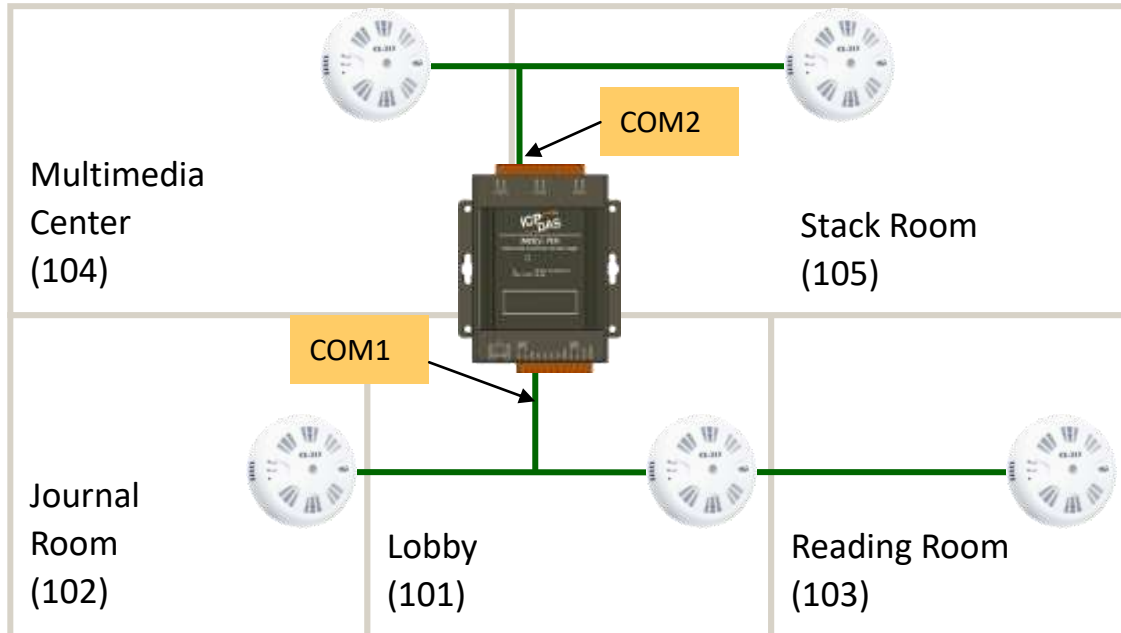

The following table shows the Modbus addresses for reading data from the CL-213 devices. This section describes how to set the MDCL-705i to collect environmental data and high alarm statuses for temperature, humidity, CO, CO₂, and PM2.5 from the CL-213 modules.

Function Code	Register	Data	Unit
0x04 (Read AI)	300000	CO	1ppm
	300001	CO ₂	1ppm
	300002	PM2.5	1ug/m ³
	300003	Humidity	0.01%
	300004	Temperature	0.01°C
0x03 (Read AO)	400452	Temperature offset	0.01°C
0x01 (Read DO), (Write 1 to clear alarm status)	000304	High alarm status of CO	
	000305	High alarm status of CO ₂	
	000306	High alarm status of PM2.5	
	000307	High alarm status of Humidity	
	000308	High alarm status of Temperature	

1. Configuring the MDCL-705i

STEP 1: Obtain the necessary information for reading data from these CL-213 devices as below:

Room	CL-213 Number	MDCL COM#	Modbus ID	Function Code	Start Address	Quantity
Lobby (101)	1	1	1	4	0	5
		1	1	3	452	1
		1	1	1	304	5
Journal Room (102)	2	1	2	4	0	5
		1	2	3	452	1
		1	2	1	304	5
Reading Room (103)	3	1	3	4	0	5
		1	3	3	452	1
		1	3	1	304	5
Multimedia Center (104)	4	2	4	4	0	5
		2	4	3	452	1
		2	4	1	304	5
Stack Room (105)	5	2	5	4	0	5
		2	5	3	452	1
		2	5	1	304	5

STEP 2: Edit the config.csv as below:

	A	B	C	D	E	F	G	H	I	J
1	#	UseComPort	SlaveModbusID	FunctionCode	RegStartAddr	RegCount	TimeoutEventProcess	PresetValue	GroupName	Description
2	*	1	1	4	0	5	2	65535	101_1	Lobby Data
3	*	1	1	3	452	1	2	65535	101_2	Lobby Offset
4	*	1	1	1	304	5	0	0	101_3	Lobby Alarm
5	*	1	2	4	0	5	2	65535	102_1	JournalR Data
6	*	1	2	3	452	1	2	65535	102_2	JournalR Offset
7	*	1	2	1	304	5	0	0	102_3	JournalR Alarm
8	*	1	3	4	0	5	2	65535	103_1	ReadR Data
9	*	1	3	3	452	1	2	65535	103_2	ReadR Offset
10	*	1	3	1	304	5	0	0	103_3	ReadR Alarm
11	*	2	4	4	0	5	2	65535	104_1	MC Data
12	*	2	4	3	452	1	2	65535	104_2	MC Offset
13	*	2	4	1	304	5	0	0	104_3	MC Alarm
14	*	2	5	4	0	5	2	65535	105_1	StackR Data
		2	5	3	452	1	2	65535	105_2	StackR Offset
		2	5	1	304	5	0	0	105_3	StackR Alarm

config.csv

A unique GroupName for each polling definition

STEP 3: Import the config.csv

STEP 4: Click the tab for a COM port on MODBUS page, and verify the parameters in polling definitions.

Polling definitions for reading data from lobby, journal room, and reading room (on COM1 tab)

#	Active	COM Port	Modbus Slave ID	Function Code	Modbus Address	Quantity	Timeout Exception	Preset Value	Group Name	Description
1	Enable	COM1	1	FC04	0	5	Mode3	65535	101_1	Lobby Data
2	Enable	COM1	1	FC03	452	1	Mode3	65535	101_2	Lobby Offset
3	Enable	COM1	1	FC01	304	5	Mode1	0	101_3	Lobby Alarm
4	Enable	COM1	2	FC04	0	5	Mode3	65535	102_1	JournalR Data
5	Enable	COM1	2	FC03	452	1	Mode3	65535	102_2	JournalR Offset
6	Enable	COM1	2	FC01	304	5	Mode1	0	102_3	JournalR Alarm
7	Enable	COM1	3	FC04	0	5	Mode3	65535	103_1	ReadR Data
8	Enable	COM1	3	FC03	452	1	Mode3	65535	103_2	ReadR Offset
9	Enable	COM1	3	FC01	304	5	Mode1	0	103_3	ReadR Alarm

Polling definitions for reading data from multimedia center and stack room (on COM2 tab)

#	Active	COM Port	Modbus Slave ID	Function Code	Modbus Address	Quantity	Timeout Exception	Preset Value	Group Name	Description
1	Enable	COM2	4	FC04	0	5	Mode3	65535	104_1	MC Data
2	Enable	COM2	4	FC03	452	1	Mode3	65535	104_2	MC Offset
3	Enable	COM2	4	FC01	304	5	Mode1	0	104_3	MC Alarm
4	Enable	COM2	5	FC04	0	5	Mode3	65535	105_1	StackR Data
5	Enable	COM2	5	FC03	452	1	Mode3	65535	105_2	StackR Offset
6	Enable	COM2	5	FC01	304	5	Mode1	0	105_3	StackR Alarm

STEP 5: Select **MAIN** from the navigation menu, click COM1 and COM2 text to open the list of definitions polled by each COM port. You can get the connection status of each definition,

GOOD indicates that the connection is normal

The screenshot displays the 'Modbus Connection' interface. At the top, there is a navigation menu with 'MAIN' highlighted. Below the menu, the interface is divided into two sections for '- COM1' and '- COM2'. Each section shows a 'RESET' button and three scan time indicators: 'NOW', 'MAX.', and 'MIN.'. Below these indicators, a list of definitions is shown, each with a 'GOOD' status and a 'Description' button. Callouts provide additional information: 'MAX., MIN. and current scan time' points to the scan time indicators; 'ID and register address of an RTU device' points to the 'Register' field; 'Mapped register address in the MDCL module' points to the 'Local Register' field; and 'Description' points to the 'Description' button.

COM Port	Definition	RTU Device Address	MDCL Module Address	Status	Description
- COM1	Def. #001	ID [01] Register [300000:300004]	Local Register [300000:300004]	GOOD	Lobby Data
	Def. #002	ID [01] Register [400452:400452]	Local Register [400000:400000]	GOOD	Lobby Offset
	Def. #003	ID [01] Register [000000:000000]	Local Register [000000:000000]	GOOD	Lobby Alarm
	Def. #004	ID [02] Register [000000:000000]	Local Register [000000:000000]	GOOD	JournalR Data
	Def. #005	ID [02] Register [400452:400452]	Local Register [400001:400001]	GOOD	JournalR Offset
	Def. #006	ID [02] Register [000304:000308]	Local Register [000005:000009]	GOOD	JournalR Alarm
	Def. #007	ID [03] Register [300000:300004]	Local Register [300010:300014]	GOOD	ReadR Data
	Def. #008	ID [03] Register [400452:400452]	Local Register [400002:400002]	GOOD	ReadR Offset
	Def. #009	ID [03] Register [000304:000308]	Local Register [000010:000014]	GOOD	ReadR Alarm
- COM2	Def. #010	ID [04] Register [300000:300004]	Local Register [300015:300019]	GOOD	MC Data
	Def. #011	ID [04] Register [400452:400452]	Local Register [400003:400003]	GOOD	MC Offset
	Def. #012	ID [04] Register [000304:000308]	Local Register [000015:000019]	GOOD	MC Alarm
	Def. #013	ID [05] Register [300000:300004]	Local Register [300020:300024]	GOOD	StackR Data
	Def. #014	ID [05] Register [400452:400452]	Local Register [400004:400004]	GOOD	StackR Offset
	Def. #015	ID [05] Register [000304:000308]	Local Register [000020:000024]	GOOD	StackR Alarm

Description
Description can be used to indicate the device or location associated with each definition. This helps users better understand the link between commands and devices, and assists with troubleshooting.

2. Reading data from multiple CL-213 devices with one Modbus TCP read command

The screenshot displays two Modbus TCP connections, COM1 and COM2. Each connection shows a list of data definitions (Def. #) with their corresponding Modbus registers and local registers. The local register addresses for five devices are highlighted with red boxes:

- COM1 Def. #001: Local Register [300000:300004]
- COM1 Def. #004: Local Register [300005:300009]
- COM1 Def. #007: Local Register [300010:300014]
- COM2 Def. #010: Local Register [300015:300019]
- COM2 Def. #013: Local Register [300020:300024]

The addresses marked with a red frame in the picture are the internal register addresses on MDCL for data collected from the five CL-213 devices. The data of temperature, humidity, CO, CO2 and PM2.5 concentration from different CL-213 devices have been arranged in consecutive addresses. Using function code 0x04 to read the data addresses from 30000 to 30024, the remote Modbus master can read data from multiple CL-213 devices with one Modbus TCP read command.

Data Location	Data Address on MDCL	Data Contents
Lobby	300000 ~ 300004	CO, CO2, PM2.5, Temperature, Humidity
Journal Room	300005 ~ 300009	CO, CO2, PM2.5, Temperature, Humidity
Reading Room	300010 ~ 300014	CO, CO2, PM2.5, Temperature, Humidity
Multimedia Center	300015 ~ 300019	CO, CO2, PM2.5, Temperature, Humidity
Stack Room	300020 ~ 300024	CO, CO2, PM2.5, Temperature, Humidity

3. Writing data to MDCL to set the holding register in the CL-213 device with Modbus TCP command

The data of temperature offset written to mapped address 400000 in MDCL with function code 0x06 will be written to the CL-213 in the lobby to change the temperature offset setting in it.

- COM1 NOW 419 ms MAX. 554 ms MIN. 407 ms RESET

Def. #001 - ID [01] Register [300000:300004] → Local Register [300000:300004]	GOOD	Lobby Data
Def. #002 - ID [01] Register [400452:400452] → Local Register [400000:400000]	GOOD	Lobby Offset
Def. #003 - ID [01] Register [000304:000308] → Local Register [000000:000004]	GOOD	Lobby Alarm

4. Writing data to MDCL to force multiple coils in the CL-213 device with Modbus TCP command

Writing the number 1 to the mapped addresses 000000 to 000004 in MDCL with function code 0x0F is equal to writing 1 to the CL-213 in the lobby to clear high alarm status of temperature, humidity, CO, CO2 and PM2.5 concentration.

- COM1 NOW 419 ms MAX. 554 ms MIN. 407 ms RESET

Def. #001 - ID [01] Register [300000:300004] → Local Register [300000:300004]	GOOD	Lobby Data
Def. #002 - ID [01] Register [400452:400452] → Local Register [400000:400000]	GOOD	Lobby Offset
Def. #003 - ID [01] Register [000304:000308] → Local Register [000000:000004]	GOOD	Lobby Alarm

5. Reserving register space for devices added in the future

Consider a scenario where iSN-201-E modules for monitoring indoor illumination need be added after this application has been running for a while. We added polling definitions for collecting the illumination values in each room in the config.csv file and imported it.



iSN-201-E

Room	Model Number	MDCL COM#	Modbus ID	Function Code	Start Address	Quantity
Lobby (101)	CL-213	1	1	4	0	5
		1	1	3	452	1
		1	1	1	304	5
	iSN-201-E	1	6	4	5	1
Journal Room (102)	CL-213	1	2	4	0	5
		1	2	3	452	1
		1	2	1	304	5
	iSN-201-E	1	7	4	5	1
Reading Room (103)	CL-213	1	3	4	0	5
		1	3	3	452	1
		1	3	1	304	5
	iSN-201-E	1	8	4	5	1
Multimedia Center (104)	CL-213	2	4	4	0	5
		2	4	3	452	1
		2	4	1	304	5
	iSN-201-E	2	9	4	5	1
Stack Room (105)	CL-213	2	5	4	0	5
		2	5	3	452	1
		2	5	1	304	5
	iSN-201-E	2	10	4	5	1

	A	B	C	D	E	F	G	H	I	J
1	#	UseComPort	SlaveModbusID	FunctionCode	RegStartAddr	RegCount	TimeoutEventProcess	PresetValue	GroupName	Description
2	*	1	1	4	0	5	2	65535	101_1	Lobby Data
3	*	1	1	3	452	1	2	65535	101_2	Lobby Offset
4	*	1	1	1	304	5	0	0	101_3	Lobby Alarm
5	*	1	2	4	0	5	2	65535	102_1	JournalR Data
6	*	1	2	3	452	1	2	65535	102_2	JournalR Offset
7	*	1	2	1	304	5	0	0	102_3	JournalR Alarm
8	*	1	3	4	0	5	2	65535	103_1	ReadR Data
9	*	1	3	3	452	1	2	65535	103_2	ReadR Offset
10	*	1	3	1	304	5	0	0	103_3	ReadR Alarm
11	*	2	4	4	0	5	2	65535	104_1	MC Data
12	*	2	4	3	452	1	2	65535	104_2	MC Offset
13	*	2	4	1	304	5	0	0	104_3	MC Alarm
14	*	2	5	4	0	5	2	65535	105_1	StackR Data
15	*	2	5	3	452	1	2	65535	105_2	StackR Offset
16	*	2	5	1	304	5	0	0	105_3	StackR Alarm
17	*	1	6	4	5	1	2	65535	101_4	Lobby Illum
18	*	1	7	4	5	1	2	65535	102_4	JournalR Illum
19	*	1	8	4	5	1	2	65535	103_4	ReadR Illum
20	*	2	9	4	5	1	2	65535	104_4	MC Illum
21	*	2	10	4	5	1	2	65535	105_4	StackR Illum

Polling definitions for reading indoor illumination

Function Code	Register	Data	Unit
0x04 (Read AI)	300005	Ambient light	1lux

The registers mapped for reading CO, CO2, PM2.5, temperature and humidity in multimedia center and stack room are changed from 300015 ~ 300024 to 300018 ~ 300027, because the register address mapped to read illumination of iSN-201-E connected to COM1 will be ranked before the registers mapped for devices connected to COM2.

Data Location	Data Address on MDCL	Data Contents
Lobby	300000 ~ 300004	CO, CO2, PM2.5, Temperature, Humidity
Journal Room	300005 ~ 300009	CO, CO2, PM2.5, Temperature, Humidity
Reading Room	300010 ~ 300014	CO, CO2, PM2.5, Temperature, Humidity
Lobby	300315	Illumination
Journal Room	300316	Illumination
Reading Room	300317	Illumination
Multimedia Center	300018 ~ 300022	CO, CO2, PM2.5, Temperature, Humidity
Stack Room	300023 ~ 300027	CO, CO2, PM2.5, Temperature, Humidity
Multimedia Center	300328	Illumination
Stack Room	300329	Illumination

Usually, we don't want to modify Modbus master programs with regard to accessing registers allocated for deployed devices every time we add a new device, so we can reserve register spaces for devices used in the future.

Previous local registers allocation

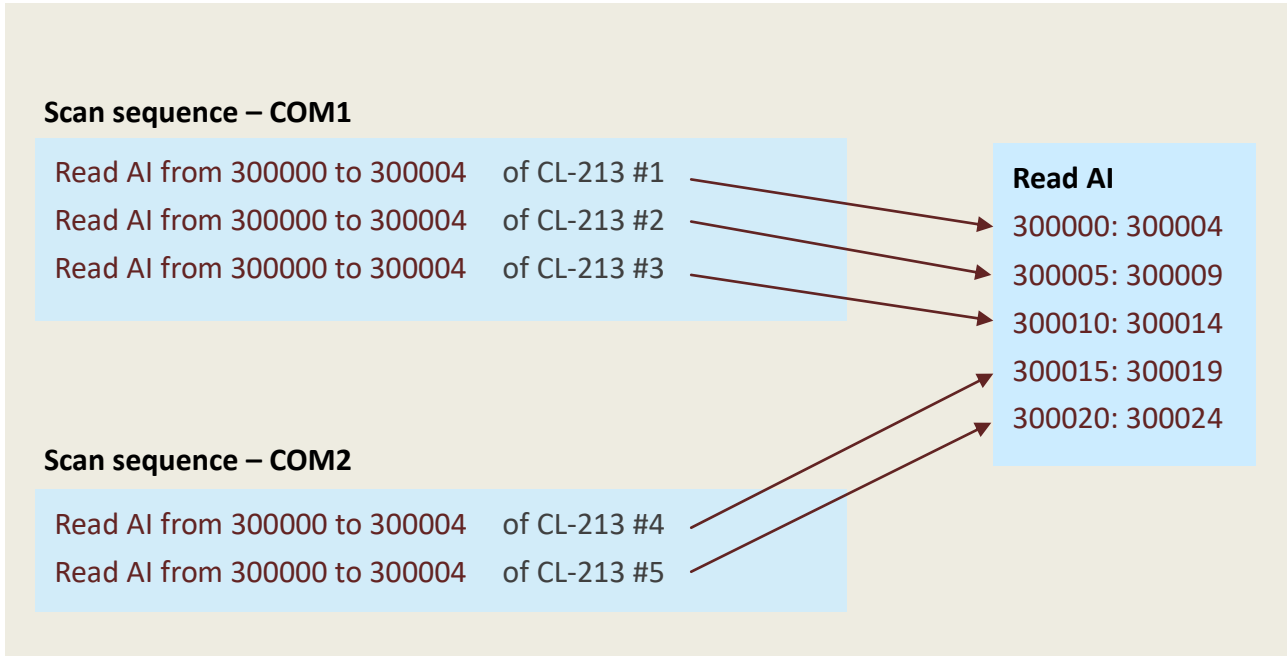

New local registers allocation of adding an iSN-201-E device in every room

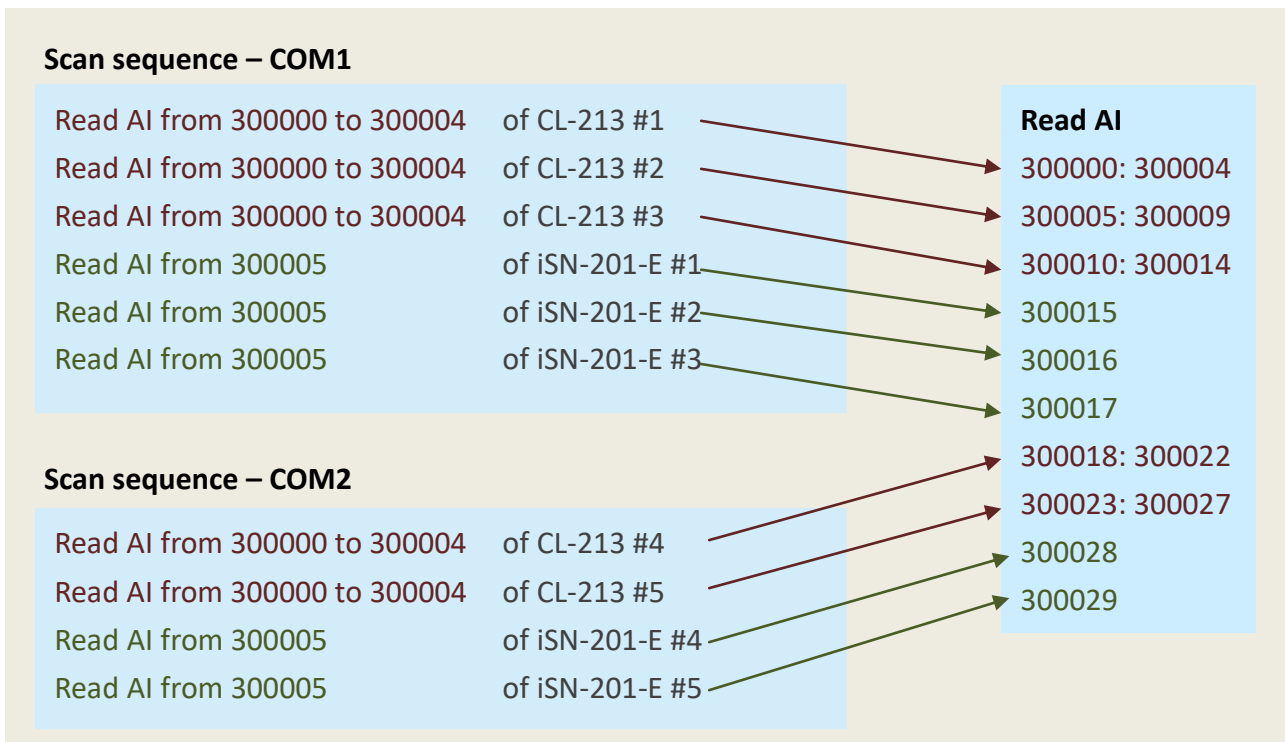

For example, we can add definition to reserve the first 100 local registers (300000 to 300099) for COM1, the second 100 registers (300100 to 300199) for COM2 and so on.

Previous local registers allocation with reserved registers

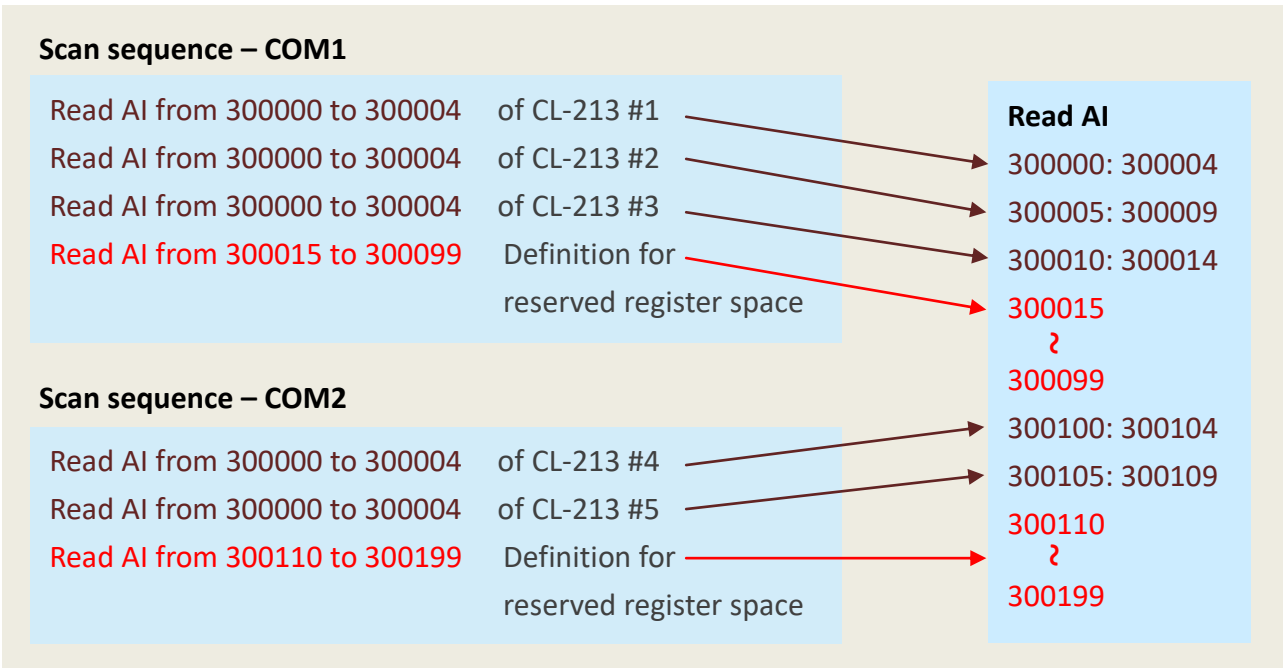

New local registers allocation of adding iSN-201-E devices with reserved registers

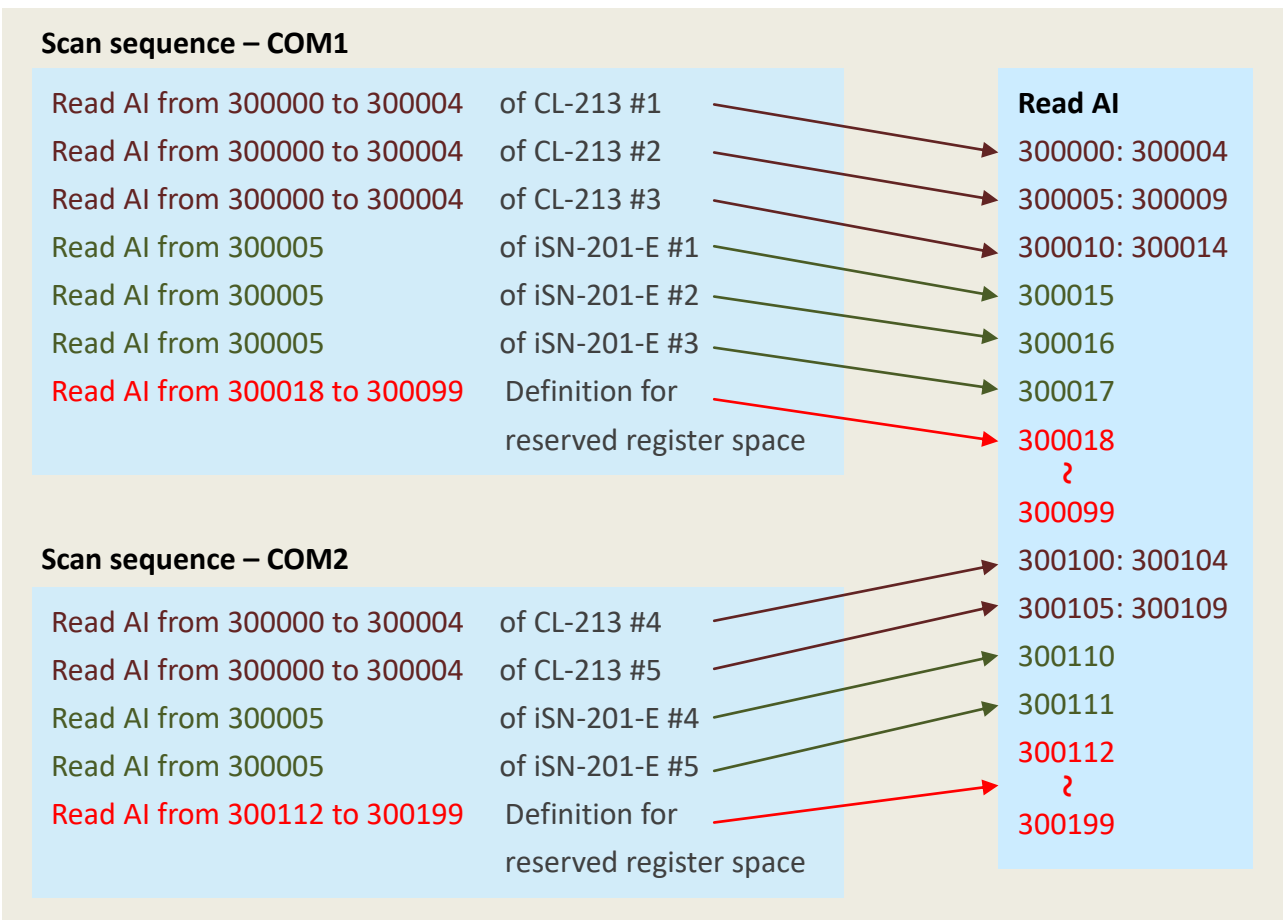

For the reason that the maximum numbers of registers that one definition can access is 125, use multiple definitions to reserve a larger register space if needed.

Reserve enough register space in the first stage

Add reserve definitions with minus sign in the first field, COM port and the amount of reserved registers, the MDCL will assign local registers for data defined in the definition but not poll data. (Refer to sec. 6.2)

7	*	1	2	1	304	5	0	0	102_3	JournalR Alarm
8	*	1	3	4	0	5	2	65535	103_1	ReadR Data
9	*	1	3	3	452	1	2	65535	103_2	ReadR Offset
10	*	1	3	1	304	5	0	0	103_3	ReadR Alarm
11	*	2	4	4	0	5	2	65535	104_1	MC Data
12	*	2	4	3	452	1	2	65535	104_2	MC Offset
13	*	2	4	1	304	5	0	0	104_3	MC Alarm
14	*	2	4	1	0	5	2	65535	105_1	StackR Data
15	*	2	4	1	0	5	2	65535	105_2	StackR Offset
16	*	2	5	1	304	5	0	0	105_3	StackR Alarm
17	*	3	1	4	0	5	2	65535	106_1	test
18	-	1	1	4	15	85	0	0	Reserve COM1	Reserve COM1
19	-	2	1	4	110	90	0	0	Reserve COM2	Reserve COM2

Specifies COM port for which the space is reserved.

Minus sign

Specifies the amount of reserved registers

Use the reserved registers in subsequent applications

Edit new polling definitions for reading data from newly added devices, and subtract the total number of registers used in these definitions from the number of previous reserved registers.

9	*	1	3	3	452	1	2	65535	103_2	ReadR Offset
10	*	1	3	1	304	5	0	0	103_3	ReadR Alarm
11	*	2	4	4	0	5	2	65535	104_1	MC Data
12	*	2	4	3	452	1	2	65535	104_2	MC Offset
13	*	2	4	1	304	5	0	0	104_3	MC Alarm
14	*	2	4	1	0	5	2	65535	105_1	StackR Data
15	*	2	5	3	452	1	2	65535	105_2	StackR Offset
16	*	2	5	1	304	5	0	0	105_3	StackR Alarm
17	*	1	6	4	5	1	2	65535	101_4	Lobby Illum
18	*	1	7	4	5	1	2	65535	102_4	JournalR Illum
19	*	1	8	4	5	1	2	65535	103_4	ReadR Illum
20	*	2	9	4	5	1	2	65535	104_4	MC Illum
21	*	2	10	4	5	1	2	65535	105_4	StackR Illum
22	-	1	1	4	18	82	0	0	Reserve COM1	Reserve COM1
23	-	2	1	4	112	88	0	0	Reserve COM2	Reserve COM2

Adds polling definitions for reading data from newly added iSN-201-E

Adjusts the value for keeping a fixed number of registers of a COM port

7. Data Logger Configuration (record.csv)

The data logger function on the MDCL-705i can record data from up to 120 channels simultaneously, it supports various types of data, including integer, float and Boolean. Users can choose to store raw data collected from Modbus slave devices, or store physical quantities converted with user-defined scaling parameters. The data log files are stored in microSD card with .csv format. The csv log files can be quickly imported into Excel or other analysis tools for further analysis.

The data logger configuration is divided into two parts: logging time settings and logging channel settings. Logging time settings are configured from the web interface, and the logging channel settings are stored in the record.csv file. The record.csv can be viewed and edited in spreadsheet applications like Microsoft Excel, or in any text editor, in which the comma character (,) typically separates each field of text.

	A	B	C	D	E	F	G	H	I
1	#	GroupName	IndexAddr	Data Type	Scale	Offset	Unit	Prefix	Alias
2	*	103_01	0	2	1	0	ppm	ReadR_L	CO
3	*	103_01	1	2	1	0	ppm	ReadR_L	CO2
4	*	103_01	2	2	1	0	ug/m3	ReadR_L	PM2.5
5	*	103_01	3	2	0.01	0	%	ReadR_L	R.H.
6	*	103_01	4	1	0.01	0	°C	ReadR_L	Temp
7	*	103_03	0	0	1	0		ReadR_L	HA_CO
8	*	103_03	1	0	1	0		ReadR_L	HA_CO2
9	*	103_03	2	0	1	0		ReadR_L	HA_PM2.5
10	*	103_03	3	0	1	0		ReadR_L	HA_R.H.

The file name record.csv cannot be changed, and the name and order of parameters in each line for a logging channel cannot be changed, too. To avoid errors caused by manual editing, you can export the record.csv file from DATA LOGGER page and modify it to meet your requirements.

7.1. Logging Interval Configuration

To meet diverse application requirements, the MDCL offers flexible data logging intervals from 5 seconds up to 6 hours, and configurable log file durations between 1 and 24 hours. Based on the value set in the **Maximum Logging Period** parameter, the MDCL-705i will automatically close the current log file and start a new one at fixed intervals aligned with the hour, beginning at midnight.

For example, if the Maximum Logging Period is set to 6 hours, new log files will be generated at 00:00:00, 06:00:00, 12:00:00, and 18:00:00. Besides the first log file, all the subsequent files will record a full six-hour period - unless logging is stopped manually or the memory is full. This design can help users more easily compare and analyze data from multiple modules.

Logging Interval Configuration

STEP 1: Scroll down the DATA LOGGER page to the Configuration section.

STEP 2: Fill the fields as required

STEP 3: Click **SAVE**.

The screenshot displays the web interface for the MDCL-705i Modbus Data Concentrator. At the top, the title 'MDCL-705i, Modbus Data Concentrator.' is visible. Below the title, a navigation bar contains 'MAIN', 'MODBUS', 'DATA LOGGER', and 'GENERAL SETTINGS'. The 'DATA LOGGER' tab is highlighted with a red box and a blue circle containing the number '1'. To the right of the navigation bar, there are icons for a cloud, a memory indicator showing '3,400 MB', and a user profile icon. A large grey arrow points downwards from the 'DATA LOGGER' tab to the configuration section below. The configuration section is enclosed in a red dotted border and contains several settings: 'Logging Active' is set to 'Enable' (indicated by a blue circle '2'); 'Logging Rate' is set to '5 Seconds'; 'Maximum Logging Period' is set to '2 Hours' (indicated by a blue circle '2'); 'Data Log Overwrite' is set to 'Stop logging when memory is full'; and 'Automatic File Upload' is set to 'Do Not Upload File'. A blue link 'Set up the configuration for FTP server' is also present. At the bottom of the configuration section, there are two buttons: 'CANCEL' and 'SAVE'. A blue circle '3' with an arrow points to the 'SAVE' button.

Items	Description	Type
Logging Active	<ul style="list-style-type: none"> • Enable: Enables data logging function. • Disable: Disables data logging function. 	Required
Logging Rate	Defines recording interval time. Data is recorded periodically at the specified interval. Available setting: 5s, 10s, 30s, 1m, 5m, 10m, 15m, 30m, 1h, 6h	Required
Maximum Logging Period	Defines the maximum logging period of log files. Log files will be created at every interval on the hour, beginning at midnight. Available setting: 1h, 2h, 6h, 12h, 24h	Required
Data Log Overwrite	Defines the action when log space becomes full. Only available with “Stop logging when memory is full”.	Required
Automatic File Update	Enable/Disable the schedule for uploading log files to the FTP server at regular intervals. Refer to Sec.4.4 FTP Server Configuration for setting the FTP server.	Required

Save new changes

Click **SAVE** to save new changes, the MDCL will prompt whether to restart the module.

- **Restart Now:** restart the modules immediately to take the changes in effect
- **Restart Later:** restart the modules later to apply all changes after completing other settings.



Restart later

If you choose Restart Later, a RESTART icon will appear on the top-right status bar. Once all configurations are complete, click this icon to apply the changes by restarting the module.

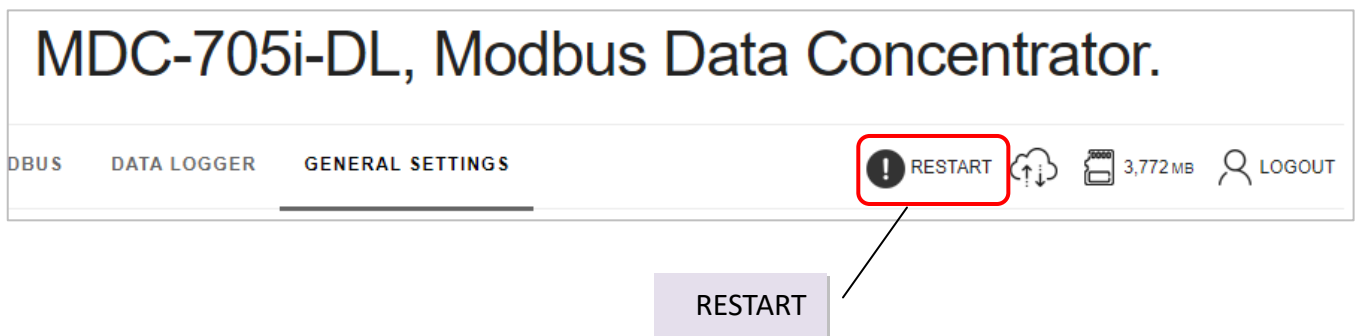

7.2. Exporting/Importing the Record.csv File

The data logging function of the MDCL-705i can record up to 120 channels of data simultaneously. It supports various types of data, including integer, float and Boolean. Users can choose to log raw data directly from devices or allow the MDCL-705i to convert raw values into readable physical units before saving. Log files are saved in CSV format, making them compatible with Excel or other data analysis tools.

All log files are stored on a microSD card. Users can access these files by copying them to a local computer, downloading them through the web interface, or configuring the system to upload them to a remote FTP server.

The log configuration file, named record.csv, has a fixed file name that cannot be changed. Additionally, the parameter names and their order for each log channel must remain unchanged. To reduce the risk of formatting errors, it is recommended to export the record.csv file from the DATA LOGGER page and edit it as needed to suit your application.

Export record.csv

STEP 1: Click **EXPORT** on the DATA LOGGER page.

STEP 2: Obtain the file from the download directory configured in the web browser.

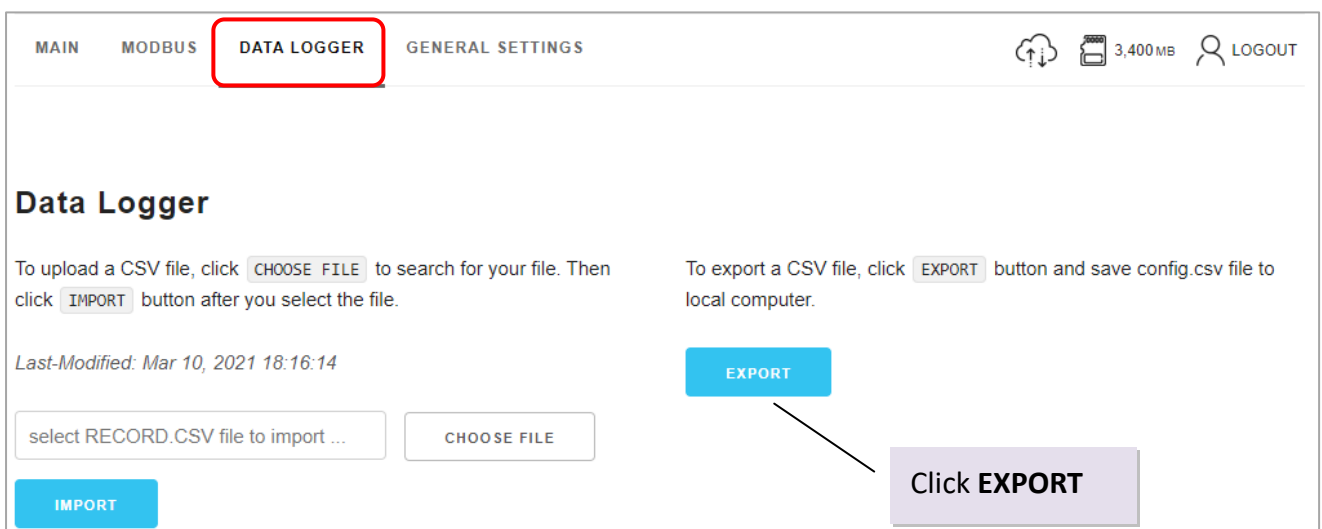

The screenshot displays the 'Data Logger' page of a web interface. At the top, there are navigation tabs: 'MAIN', 'MODBUS', 'DATA LOGGER' (highlighted with a red box), and 'GENERAL SETTINGS'. On the right side of the header, there are icons for a cloud upload, a storage icon labeled '3,400 MB', and a 'LOGOUT' button. The main content area is titled 'Data Logger' and contains two columns of instructions. The left column says: 'To upload a CSV file, click **CHOOSE FILE** to search for your file. Then click **IMPORT** button after you select the file.' Below this, it shows a text input field with the placeholder 'select RECORD.CSV file to import ...', a 'CHOOSE FILE' button, and an 'IMPORT' button. The right column says: 'To export a CSV file, click **EXPORT** button and save config.csv file to local computer.' Below this, there is a blue 'EXPORT' button. A callout box with an arrow points to the 'EXPORT' button, containing the text 'Click **EXPORT**'. At the bottom left, the text 'Last-Modified: Mar 10, 2021 18:16:14' is visible.

Import record.csv

STEP 1: Click **CHOOSE FILE** on the DATA LOGGER page and then select your record.csv file.

STEP 2: Click **IMPORT**.

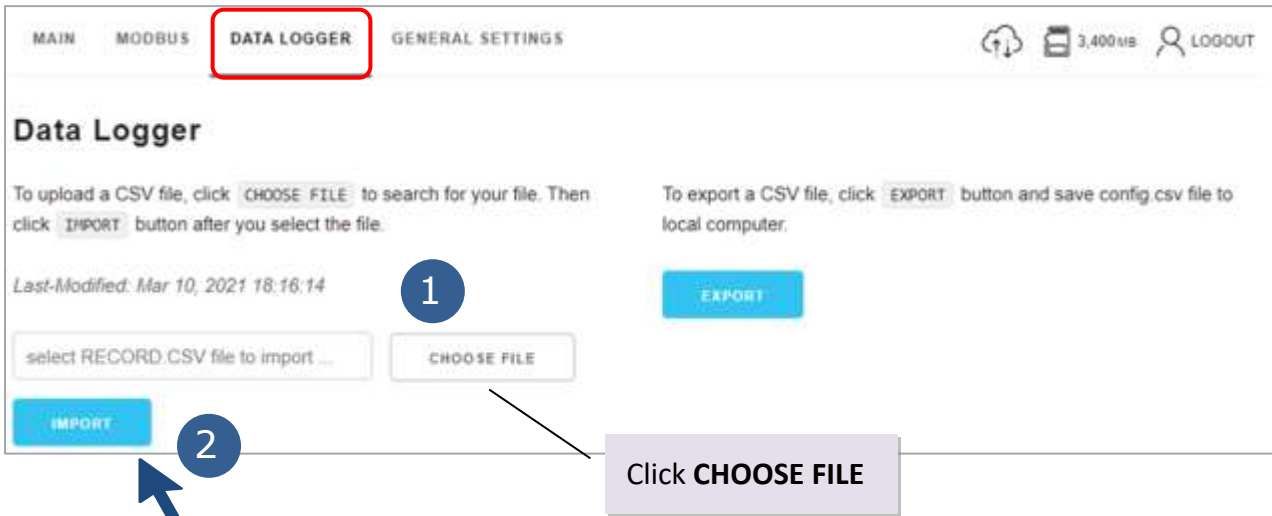

MDCL can help users to validate the imported file and present the result as success or error message with line and position information of invalid settings as shown below. A channel will not be recorded if any of its setting is invalid.

Success message

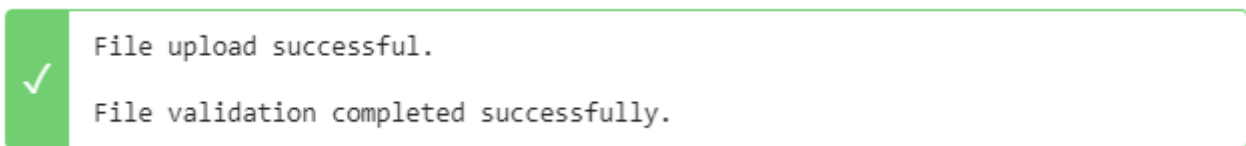

Error message (A channel with invalid setting will not be recorded.)

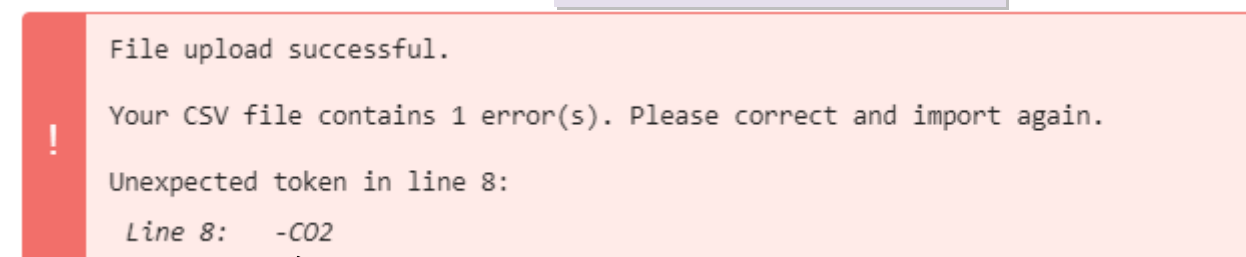
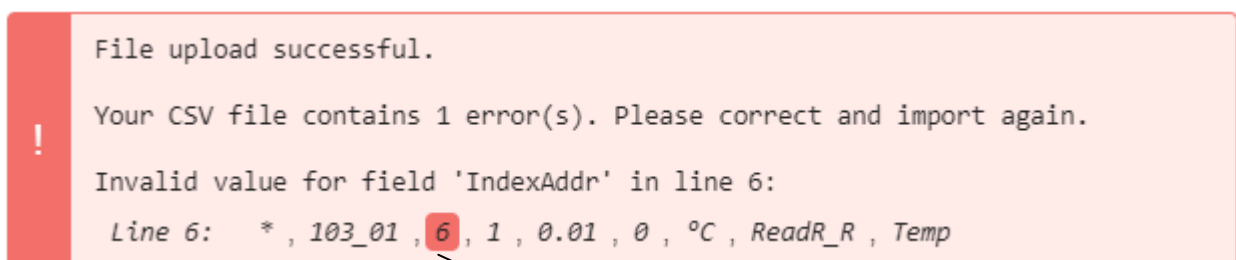

7.3. Logging Channels Configuration (Record.csv)

Up to 120 channels of data can be logged by the MDCL with timestamp and user-defined scaling. The configuration parameters for log channels are saved in the record.csv file.

Before start to configure parameters for log channels, be sure to confirm the data type, the GroupName set in the config.csv file of a channel and the index address (starting from 0) in its group.

	A	B	C	D	E	F	G	H	I
1	#	GroupName	IndexAddr	DataType	Scale	Offset	Unit	Prefix	Alias
2	*	103_01	0	2	1	0	ppm	ReadR_L	CO
3	*	103_01	1	2	1	0	ppm	ReadR_L	CO2
4	*	103_01	2	2	1	0	ug/m3	ReadR_L	PM2.5
5	*	103_01	3	2	0.01	0	%	ReadR_L	R.H.
6	*	103_01	4	1	0.01	0	°C	ReadR_L	Temp
7	*	103_03	0	0	1	0		ReadR_L	HA_CO
8	*	103_03	1	0	1	0		ReadR_L	HA_CO2
9	*	103_03	2	0	1	0		ReadR_L	HA_PM2.5
10	*	103_03	3	0	1	0		ReadR_L	HA_R.H.

The file name **record.csv** cannot be changed, and the name and order of parameters cannot be changed, too. Each line defines a set of log parameters for one log channel, and up to 120 channels can be configured in the record.csv file.

NOTE:

- The characters "-", "*", "~" and "#" are reserved and cannot be used in text field including the **GroupName**, **Unit**, **Prefix** and **Alias** fields

Description of parameters for a log channel:

Items	Description	Type																																	
#	<p>Defines the active type for a log channel:</p> <ul style="list-style-type: none"> • “*”: The asterisk symbol denotes that the data logging function of the specified channel is enabled. • “~”: The swung dash symbol denotes that the data logging function of the specified channel is disabled. • “ ”: A blank field denotes that the log channel is unused. <p>When this field is left blank, the specified channel is not included in the limit of 120 channels and will not be saved in the MDCL module; it can be used store configuration of a temporarily unused channel.</p>	Required																																	
Group Name (*1)	The Group Name entered here must be in line with the Group Name used in config.csv for the specified channel. If not, the setting becomes invalid and the data on this channel will not be recorded.	Required																																	
Index Addr	The index address in its group starting from 0.	Required																																	
Data Type	<p>The MDCL supports a variety of data types as follows. The data type must be exactly the same as the definition of the channel on the slave device. 16-bit data and 32-bit data use a different number of registers. When setting the Index Addr parameter, pay attention to the interval of each type of data.</p> <table border="1"> <thead> <tr> <th>No.</th> <th>Data Type</th> <th>Register</th> </tr> </thead> <tbody> <tr> <td>0</td> <td>Boolean</td> <td>1</td> </tr> <tr> <td>1</td> <td>16-bit Signed Integer</td> <td>1</td> </tr> <tr> <td>2</td> <td>16-bit Unsigned Integer</td> <td>1</td> </tr> <tr> <td>3</td> <td>16-bit Integer in Hex</td> <td>1</td> </tr> <tr> <td>4</td> <td>32-bit Signed Integer</td> <td>2</td> </tr> <tr> <td>20</td> <td>32-bit Signed Integer Swapped</td> <td>2</td> </tr> <tr> <td>5</td> <td>32-bit Unsigned Integer</td> <td>2</td> </tr> <tr> <td>21</td> <td>32-bit Unsigned Integer Swapped</td> <td>2</td> </tr> <tr> <td>7</td> <td>32-bit Floating</td> <td>2</td> </tr> <tr> <td>23</td> <td>32-bit Floating Swapped</td> <td>2</td> </tr> </tbody> </table>	No.	Data Type	Register	0	Boolean	1	1	16-bit Signed Integer	1	2	16-bit Unsigned Integer	1	3	16-bit Integer in Hex	1	4	32-bit Signed Integer	2	20	32-bit Signed Integer Swapped	2	5	32-bit Unsigned Integer	2	21	32-bit Unsigned Integer Swapped	2	7	32-bit Floating	2	23	32-bit Floating Swapped	2	Required
No.	Data Type	Register																																	
0	Boolean	1																																	
1	16-bit Signed Integer	1																																	
2	16-bit Unsigned Integer	1																																	
3	16-bit Integer in Hex	1																																	
4	32-bit Signed Integer	2																																	
20	32-bit Signed Integer Swapped	2																																	
5	32-bit Unsigned Integer	2																																	
21	32-bit Unsigned Integer Swapped	2																																	
7	32-bit Floating	2																																	
23	32-bit Floating Swapped	2																																	

Scale	Defines the slope of the formula for converting raw data into physical quantities. This should be set as a positive value. Default value: 1 Up to 10 digits including decimal point are available.	Optional
Offset	Defines the offset of the formula for converting raw data into physical quantities. Default value: 0 Up to 10 digits including decimal point and negative sign are available.	Optional
Unit (*1)	Defines the unit of the channel data Up to 8 ASCII characters are available.	Optional
Prefix (*1)	Defines the prefix of the channel name in the log file. The name of a channel in log files consists of the text in the Prefix and Alias fields. Prefix can be used to note the location or device name where the measurement is taken. Up to 16 ASCII characters are available.	Required
Alias (*1)	Defines the alias of the channel name in the log file. The name of a channel in log files consists of the text in the Prefix and Alias fields. Alias can be used to note the measurement target. Up to 16 ASCII characters are available.	Required

NOTE:

- *1. The characters "-", "*", "~" and "#" are reserved and cannot be used in text field including the **GroupName**, **Unit**, **Prefix** and **Alias** fields

GroupName

The GroupName for a channel must contain the exact text (case-sensitive) you enter for the polling definition that the channel included in the config.csv file.

config.csv

	A	B	C	D	E	F	G	H	I	J	
1	#	UseComPort	SlaveModbusID	FunctionCode	RegStartAddr	RegCount	TimeoutEventProcess	PresetValue	GroupName	Description	
2	*	1	1	3	0	1		0	COM1_0000	COM1_01_FC03_000	
3	*	1	1	3	1	2		0	COM1_0001	COM1_01_FC03_001	
4	*	1	1	3	3	4		0	COM1_0002	COM1_01_FC03_003	
5	*	1	1	3	7	8		0	COM1_0003	COM1_01_FC03_007	
6	*	1	1	3	15	16		2	0	COM1_0004	COM1_01_FC03_015
7	*	1	1	3	31	32		2	0	COM1_0005	COM1_01_FC03_031
8	*	1	1	3	63	64		2	0	COM1_0006	COM1_01_FC03_063

record.csv

	A	B	C	D	E	F	G	H	I
1	#	GroupName	IndexAddr	Data Type	Scale	Offset	Unit	Prefix	Alias
2	*	COM1_0000	0	3	10	4	ppm	COM1_0000	FC03_000_01
3	*	COM1_0001	0	1	1	0	ppm	COM1_0001	FC03_001_01
4	*	COM1_0001	1	2	0.001	1	ug/m3	COM1_0001	FC03_001_02
5	*	COM1_0002	0	4	1	5	%	COM1_0002	FC03_003_01
6	*	COM1_0002	2	20	1	0		COM1_0002	FC03_003_02

Data Type

32-bit integer and floating-point data uses two registers, as well we 16-bit integer data uses one register. When setting the ModbusAddr, the corresponding address interval must be reserved according to the number of registers used by the data type of the specified channel.

Setting Number	Data Type	Register Count	Available Range
0	Boolean	1	0,1
1	16-bit Signed Integer	1	-32,768 to 32,767
2	16-bit Unsigned Integer	1	0 to 65,535
3	16-bit Integer in Hex	1	0000 to FFFF
4	32-bit Signed Integer	2	-2,147,483,648 to 2,147,483,647
20	32-bit Signed Integer, Swapped	2	-2,147,483,648 to 2,147,483,647
5	32-bit Unsigned Integer	2	0 to 4,294,967,295
21	32-bit Unsigned Integer, Swapped	2	0 to 4,294,967,295
7	32-bit Floating	2	-3.402E+38 to +3.402E+38
23	32-bit Floating, Swapped	2	-3.402E+38 to +3.402E+38

Scale and Offset (User-Defined Scaling)

User-Defined Scaling in the MDCL is provided for converting Modbus readings to physical values such as temperature, pressure, flow, acceleration, and position. It is useful for users to recode, analyze and present data with engineering units. Scaling can be accomplished by applying scale factor (slope) and offset (y intercept) for one channel in record.csv.

The following formula is used to calculate scaling:

$$\text{Actual value} = \text{Modbus Reading} * \text{Scale} + \text{Offset}$$

The scale (slope) is the rise over the run; that is, how much the line rises vertically compared with how much it runs horizontally. Here we use two given points to calculate the slope and offset.

Example 1: Converting reading of K type thermocouple from the M-7018 into degrees Celsius

Input type: K type thermocouple (0F)

Data Format

	Modbus Reading	Actual Temperature
High	13720	1372°C
Low	-2700	-270°C

$$\begin{aligned} \text{Scale} &= \frac{\Delta y}{\Delta x} = \frac{(y_2 - y_1)}{(x_2 - x_1)} = \frac{(\text{Actual}_{\text{High}} - \text{Actual}_{\text{Low}})}{(\text{Reading}_{\text{High}} - \text{Reading}_{\text{Low}})} \\ &= \frac{1372 - (-270)}{13720 - (-2700)} \\ &= 0.1 \end{aligned}$$

$$\text{Offset} = \text{Actual value} - \text{Modbus Reading} * \text{Scale}$$

$$= 1372 - (13720 * 0.1)$$

$$= 0$$

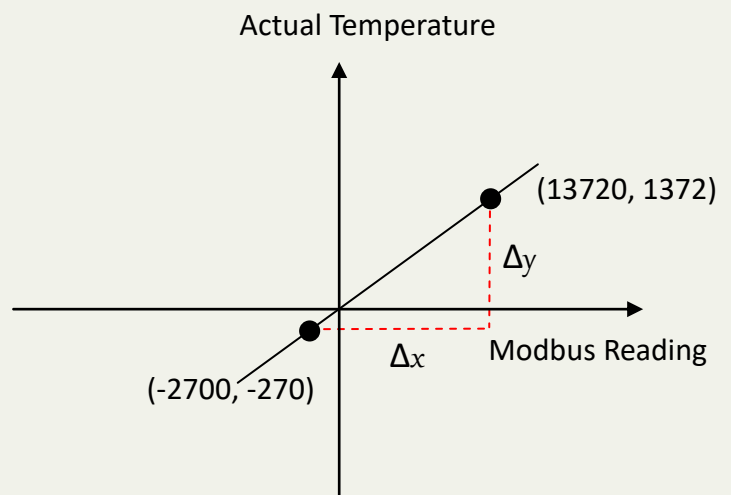

Example 2: Converting reading of K type thermocouple from the M-7018 into degrees Fahrenheit

Input type: K type thermocouple (0F)

Data Format

	Modbus Reading	Actual Temperature	Actual Temperature
High	13600	2480°F	1360°C
Low	-2700	-454°F	-260°C

$$\begin{aligned} \text{Scale} &= \frac{\Delta y}{\Delta x} = \frac{(y_2 - y_1)}{(x_2 - x_1)} = \frac{(\text{Actual}_{\text{High}} - \text{Actual}_{\text{Low}})}{(\text{Reading}_{\text{High}} - \text{Reading}_{\text{Low}})} \\ &= \frac{2480 - (-454)}{13600 - (-2700)} \\ &= 0.18 \end{aligned}$$

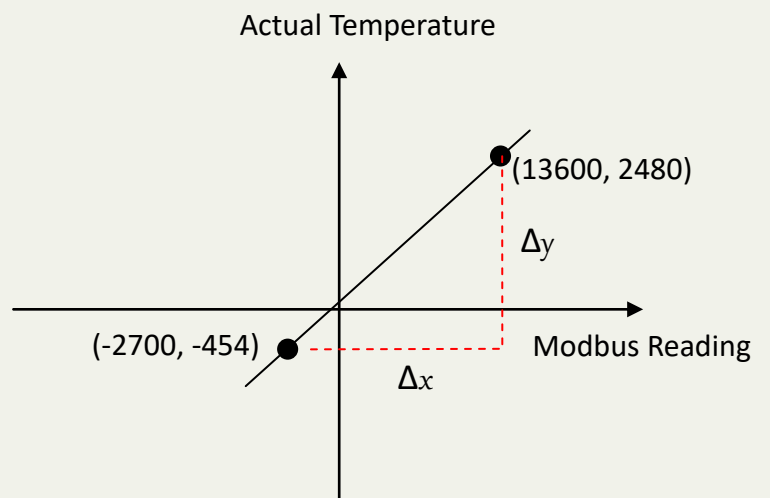

$$\text{Offset} = \text{Actual value} - \text{Modbus Reading} * \text{Scale}$$

$$\begin{aligned} &= 2480 - (13600 * 0.18) \\ &= 32 \end{aligned}$$

Example 3: Converting reading of 4-20mA pressure transmitters from the M-7018

Input type: +4 mA ~ +20 mA (07)

Data Format

	Modbus Reading	Corresponding current	Actual Pressure
High	20000	+20 mA	1000 bar
Low	4000	+4 mA	0 bar

$$\text{Scale} = \frac{\Delta y}{\Delta x} = \frac{(y_2 - y_1)}{(x_2 - x_1)} = \frac{(\text{Actual}_{\text{High}} - \text{Actual}_{\text{Low}})}{(\text{Reading}_{\text{High}} - \text{Reading}_{\text{Low}})}$$

$$= \frac{1000 - 0}{20000 - 4000}$$

$$= 0.0625$$

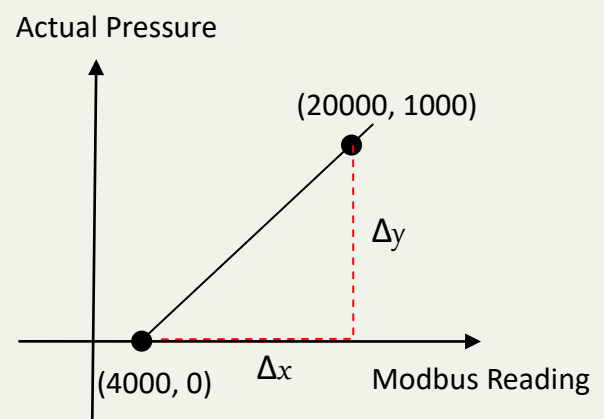

$$\text{Offset} = \text{Actual value} - \text{Modbus Reading} * \text{Scale}$$

$$= 1000 - (20000 * 0.0625)$$

$$= -250$$

Prefix and Alias

The text set for Prefix and Alias may be up to 16 ASCII characters including numeric(0-9) and alphabetic(case-sensitive) or a combination of these, except the reserved characters "-", "*", "~" and "#". The name of a channel in log files consists of Prefix and Alias. Prefix can be used to note the location or device name where the measurement is taken, and Alias can be used to note the measurement target.

record.csv									
	A	B	C	D	E	F	G	H	I
1	#	GroupName	IndexAddr	DataType	Scale	Offset	Unit	Prefix	Alias
2	*	COM1_0000	0	3	10	4	ppm	COM1_0000	FC03_000_01
3	*	COM1_0001	0	1	1	0	ppm	COM1_0001	FC03_001_01
4	*	COM1_0001	1	2	0.001	1	ug/m3	COM1_0001	FC03_001_02
5	*	COM1_0002	0	4	1	5	%	COM1_0002	FC03_003_01
6	*	COM1_0002	2	20	1	0	%	COM1_0002	FC03_003_02

COM1_0000.FC03_000_01

Log file				
	A	B	C	D
1	ver1.0	10.1.112.10	00:0D:E0:75:86:00	MDCL-705i
2		UINT16[3]	UINT16[1]	UINT16[2]
3		ppm	ppm	ug/m3
4	DATETIME	COM1_0000.FC03_000_01	COM1_0000.FC03_001_01	COM1_0000.FC03_001_02
5	2021/3/16 14:00:00	0	65535	1
6	2021/3/16 14:00:05	0	65534	1
7	2021/3/16 14:00:10	0	65535	1
8	2021/3/16 14:00:15	0	65535	1
9	2021/3/16 14:00:20	0	65535	1
10	2021/3/16 14:00:25	0	65535	1

7.4. Viewing Log Channel Settings

After the record.csv file is imported, the valid log channel settings will be listed below the log properties configuration section.

STEP 1: Scroll down the **DATA LOGGER** page to see the log channel list.

STEP 2: Check that all channels are correctly set up.

The screenshot displays the 'Data Logger' configuration interface. At the top, there are several configuration sections: 'Logging Active' (set to 'Enable'), 'Logging Rate' (set to '10 Seconds'), 'Maximum Logging Period' (set to '6 Hours'), and 'Data Log Overwrite' (set to 'Stop logging when memory is full'). Below these is the 'Automatic File Upload' section (set to 'Do Not Upload File') with a link to 'Set up the configuration for FTP server'. A 'RELOAD' button is visible. A table lists the log channel settings, with a '10 items per page' dropdown menu. Callout boxes highlight the 'RELOAD' button as 'Reload list', the '10 items per page' dropdown as 'Select how many items per page', and the table as 'Log channel settings list'.

#	Active	Group Name	Index Address	Data Type	Scale	Offset	Unit	Prefix	Alias
1	Enable	COM1_0000	0	16-bit Integer in Hex	10	4	ppm	COM1_0000	FC03_000_01
2	Enable	COM1_0001	0	16-bit Signed Integer	1	0	ppm	COM1_0001	FC03_001_01
3	Enable	COM1_0001	1	16-bit Unsigned Integer	0.001	1	ug/m3	COM1_0001	FC03_001_02
4	Enable	COM1_0002	0	32-bit Signed Integer	1	5	%	COM1_0002	FC03_003_01
5	Enable	COM1_0002	2	32-bit Signed Integer Swap	1	0		COM1_0002	FC03_003_02

7.5. Downloading Log Files

Log files in MDCL are saved in comma separated values (CSV) format, which can be imported into Excel for further analysis. The log file name consists of prefix "T_" and creation date and time in mmddhh format.

If **Maximum Logging Period** is set to 6 hours, the MDCL will close the current file and create a new file every 6 hours on the hour starting at midnight (0:00:00, 6:00:00, 12:00:00, 18:00:00). The time for the first file to record data may be less than 6 hours. This design can help users compare and analyze data from multiple modules more quickly.

MDCL will automatically restart itself and adopt new settings for log channels while a new record.csv is imported successfully. And new data will be appended to the logging file without modifying the previous header content. At this time, you have to modify the header content and remove data recorded before the point in time when the record.csv file is imported in the first log file.

Download log file

STEP 1: Click **FILE MANAGER** on GENERAL SETTINGS page and click on the calendar icon.

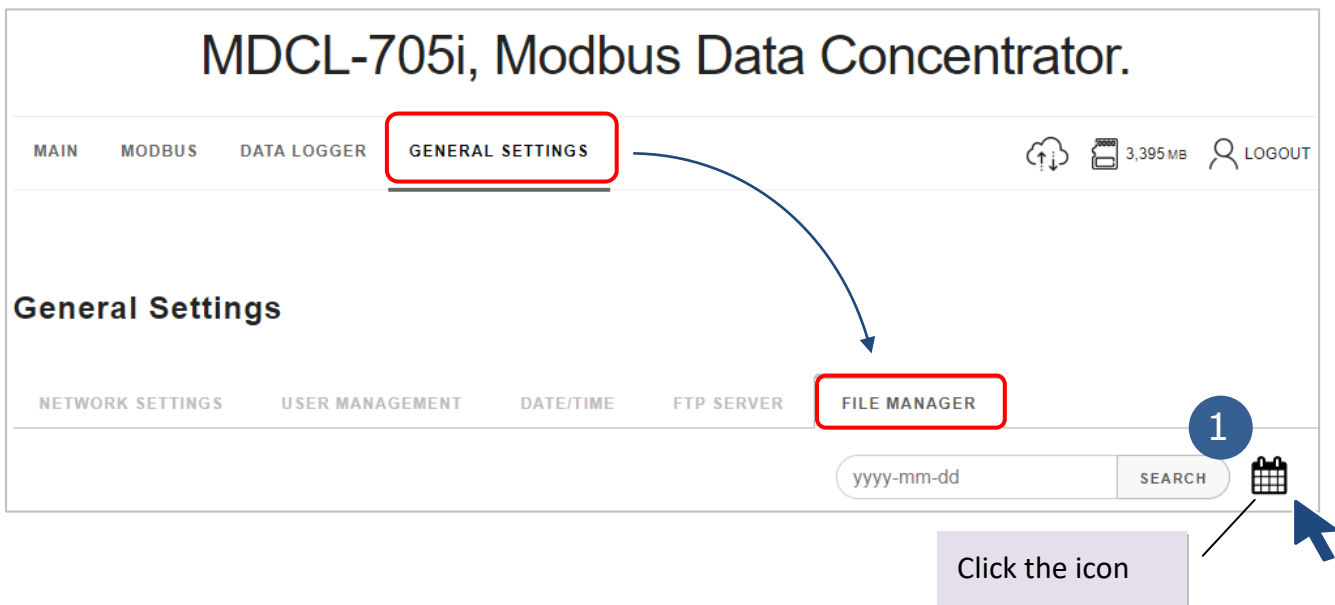

STEP 2: Select the date of the log files and click **SEARCH**.

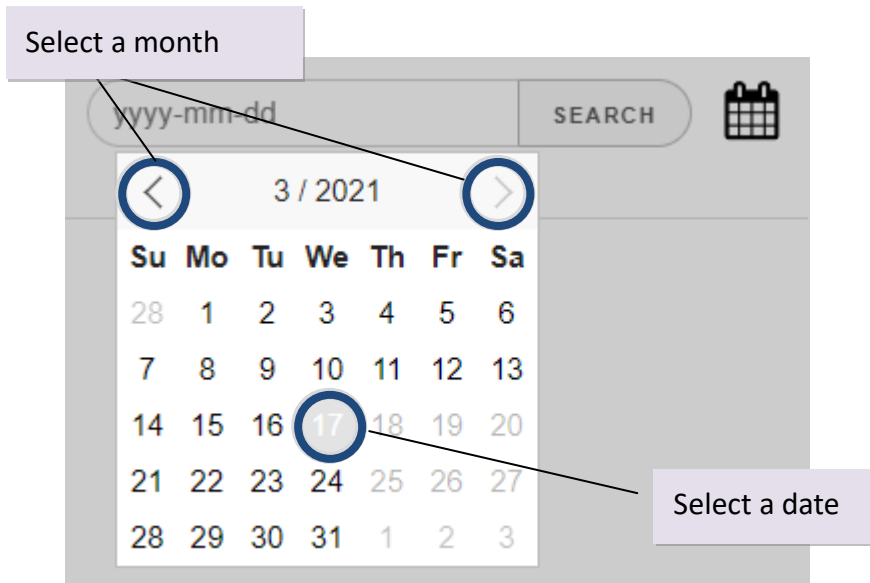

STEP 3: Click the **DOWNLOAD** icon for a file to download it.

Date Created	Name	Size	DOWNLOAD	DELETE
2021-03-17	T_031700.CSV	133,050	DOWNLOAD	DELETE
2021-03-17	T_031702.CSV	133,050	DOWNLOAD	DELETE
2021-03-17	T_031704.CSV	133,050	DOWNLOAD	DELETE
2021-03-17	T_031706.CSV	133,050	DOWNLOAD	DELETE
2021-03-17	T_031708.CSV	112,810	DOWNLOAD	DELETE
5 file(s)		645,010 bytes		

STEP 4: Get the file in the default download directory of web browser. Downloading the data does not delete it from the MDCL.

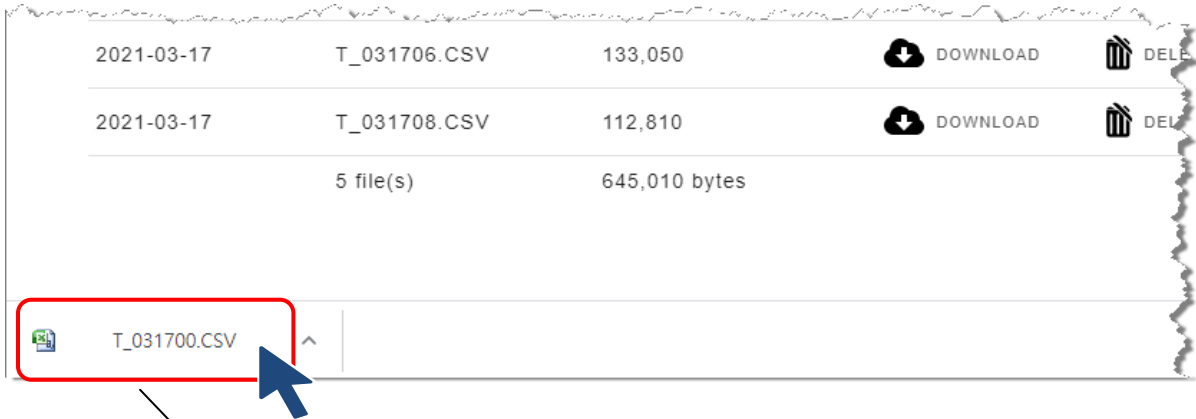

File name T_031700 created at 00:00:00, on March 17th.

Each MDCL log file consists of a file header and log entries as shown below. The first 4 lines are header information including the MDCL firmware version, IP address, MAC address module name, and data type, unit and name for each channel. After that are logged entries with timestamps.

	A	B	C	D	E
1	ver1.0	10.1.112.10	00:0D:E0:FF:70:51	MDC-705i-DL	
2		INT16[3]	INT16[1]	UINT16[2]	INT32[4]
3		mA			
4	DATETIME	COM1_0000.FC03_000_01	COM1_0001.FC03_001_02	COM1_0001.FC03_001_03	
5	2021/3/17 00:00:00	0	0	0	5
6	2021/3/17 00:00:10	0	0	1	5
7	2021/3/17 00:00:20	0	0	0	5
8	2021/3/17 00:00:30	0	0	0	5
9	2021/3/17 00:00:40	0	0	1	5
10	2021/3/17 00:00:50	0	0	1	5
11	2021/3/17 00:01:00	0	0	1	5
12	2021/3/17 00:01:10	0	0	1	5
13	2021/3/17 00:01:20	0	0	1	5
14	2021/3/17 00:01:30	0	0	1	5
15	2021/3/17 00:01:40	0	0	1	5
16	2021/3/17 00:01:50	0	0	1	5
17	2021/3/17 00:02:00	0	0	1	5
18	2021/3/17 00:02:10	0	0	1	5

Delete file

STEP 1: Click the **DELETE** icon for a file, then click the DELETE button in the confirmation message.

2021-01-12	T_011212.CSV	15,331	DOWNLOAD	DELETE
2021-01-12	T_011212.CSV	15,331	Are you sure to delete this? <input type="button" value="CANCEL"/> <input type="button" value="DELETE"/>	

7.6. Application

Environmental monitoring and logging in a community library

The following section will introduce the steps for logging data collected in the environmental monitoring application in section 6.4.

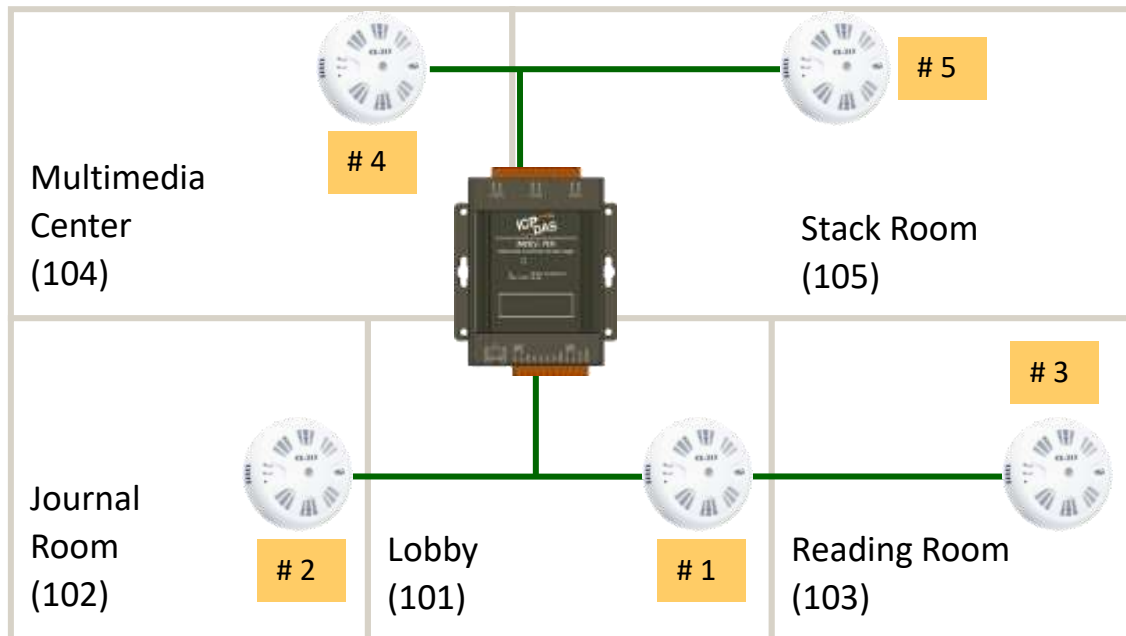

1. Configuring log channels

The following table shows polling definitions for reading temperature, humidity, CO, CO2 and PM2.5 concentration from the 5 CL-213 devices in the community library.

config.csv

	A	B	C	D	E	F	G	H	I	J
1	#	UseComPort	SlaveModbusID	FunctionCode	RegStartAddr	RegCount	TimeoutEventProcess	PresetValue	GroupName	Description
2	*	1	1	4	0	5	2	65535	101_1	Lobby Data
3	*	1	2	4	0	5	2	65535	102_1	JournalR Data
4	*	1	3	4	0	5	2	65535	103_1	ReadR Data
5	*	2	4	4	0	5	2	65535	104_1	MC Data
6	*	2	5	4	0	5	2	65535	105_1	StackR Data

The detail information of logging channel of a CL-213 device including temperature, humidity, CO, CO2 and PM2.5 concentration are shown below:

Address in Group	Data	Range	Unit	Data Type
0	CO	0 ~ 1000	1ppm	2 (U16)
1	CO2	0 ~ 9999	1ppm	2 (U16)
2	PM2.5	0 ~ 400	1ug/m ³	2 (U16)
3	Humidity	0 ~ 10000	0.01%	2 (U16)
4	Temperature	-1000 ~ +5000	0.01°C	1 (I16)

Edit record.csv

	A	B	C	D	E	F	G	H	I
1	#	GroupName	IndexAddr	Data Type	Scale	Offset	Unit	Prefix	Alias
2	*	101_1	0	2	1	0	ppm	Lobby	CO
3	*	101_1	1	2	1	0	ppm	Lobby	CO2
4	*	101_1	2	2	1	0	ug/m3	Lobby	PM2.5
5	*	101_1	3	2	0.01	0	%	Lobby	Humidity
6	*	101_1	4	1	0.01	0	°C	Lobby	Temperature
7	*	102_1	0	2	1	0	ppm	JournalRoom	CO
8	*	102_1	1	2	1	0	ppm	JournalRoom	CO2
9	*	102_1	2	2	1	0	ug/m3	JournalRoom	PM2.5
10	*	102_1	3	2	0.01	0	%	JournalRoom	Humidity
11	*	102_1	4	1	0.01	0	°C	JournalRoom	Temperature
12	*	103_1	0	2	1	0	ppm	ReadingRoom	CO
13	*	103_1	1	2	1	0	ppm	ReadingRoom	CO2
14	*	103_1	2	2	1	0	ug/m3	ReadingRoom	PM2.5
15	*	103_1	3	2	0.01	0	%	ReadingRoom	Humidity
16	*	103_1	4	1	0.01	0	°C	ReadingRoom	Temperature
17	*	104_1	0	2	1	0	ppm	MultimediaCenter	CO
18	*	104_1	1	2	1	0	ppm	MultimediaCenter	CO2
19	*	104_1	2	2	1	0	ug/m3	MultimediaCenter	PM2.5
20	*	104_1	3	2	0.01	0	%	MultimediaCenter	Humidity
21	*	104_1	4	1	0.01	0	°C	MultimediaCenter	Temperature
22	*	105_1	0	2	1	0	ppm	StackRoom	CO
23	*	105_1	1	2	1	0	ppm	StackRoom	CO2
24	*	105_1	2	2	1	0	ug/m3	StackRoom	PM2.5
25	*	105_1	3	2	0.01	0	%	StackRoom	Humidity
26	*	105_1	4	1	0.01	0	°C	StackRoom	Temperature

config.csv

	A	B	C	D	E	F	G	H	I	J
1	#	UseComPort	SlaveModbusID	FunctionCode	RegStartAddr	RegCount	TimeoutEventProcess	PresetValue	GroupName	Description
2	*	1	1	4	0	5	2	65535	101_1	Lobby Data
3	*	1	2	4	0	5	2	65535	102_1	JournalR Data
4	*	1	3	4	0	5	2	65535	103_1	ReadR Data
5	*	2	4	4	0	5	2	65535	104_1	MC Data
6	*	2	5	4	0	5	2	65535	105_1	StackR Data

2. Importing record.csv

STEP 1: Click **CHOOSE FILE** on DATA LOGGER page and then select your record.csv file.

STEP 2: Click **IMPORT**.

The screenshot shows the 'DATA LOGGER' page in a web application. The navigation menu at the top includes 'MAIN', 'MODBUS', 'DATA LOGGER' (highlighted with a red box), and 'GENERAL SETTINGS'. On the right, there are icons for cloud storage, a file icon with '3,400 MB', and a 'LOGOUT' button. The main content area is titled 'Data Logger' and contains instructions: 'To upload a CSV file, click **CHOOSE FILE** to search for your file. Then click **IMPORT** button after you select the file.' and 'To export a CSV file, click **EXPORT** button and save config.csv file to local computer.' Below the text, there is a text input field with the placeholder 'select RECORD.CSV file to import ...', a 'CHOOSE FILE' button, and an 'EXPORT' button. A blue circle with the number '1' points to the 'CHOOSE FILE' button, and a callout box with the text 'Click **CHOOSE FILE**' has an arrow pointing to it. Below the input field, there is an 'IMPORT' button, and a blue circle with the number '2' and a mouse cursor arrow points to it.

See success message

A green-bordered box with a green checkmark icon on the left. It contains two lines of text: 'File upload successful.' and 'File validation completed successfully.'

After the record.csv is imported into the MDCL, scroll down the DATA LOGGER page and check the channel settings.

Channel configuration for logging data from the lobby and journal room

#	Active	Group Name	Index Address	Data Type	Scale	Offset	Unit	Prefix	Alias
1	Enable	101_1	0	16-bit Unsigned Integer	1	0	ppm	Lobby	CO
2	Enable	101_1	1	16-bit Unsigned Integer	1	0	ppm	Lobby	CO2
3	Enable	101_1	2	16-bit Unsigned Integer	1	0	ug/m3	Lobby	PM2.5
4	Enable	101_1	3	16-bit Unsigned Integer	0.01	0	%	Lobby	Humidity
5	Enable	101_1	4	16-bit Signed Integer	0.01	0	°C	Lobby	Temperature
6	Enable	102_1	0	16-bit Unsigned Integer	1	0	ppm	JournalRoom	CO
7	Enable	102_1	1	16-bit Unsigned Integer	1	0	ppm	JournalRoom	CO2
8	Enable	102_1	2	16-bit Unsigned Integer	1	0	ug/m3	JournalRoom	PM2.5
9	Enable	102_1	3	16-bit Unsigned Integer	0.01	0	%	JournalRoom	Humidity
10	Enable	102_1	4	16-bit Signed Integer	0.01	0	°C	JournalRoom	Temperature

« < 1 2 3 > »

Channel configuration for logging data from the reading room and multimedia center

#	Active	Group Name	Index Address	Data Type	Scale	Offset	Unit	Prefix	Alias
11	Enable	103_1	0	16-bit Unsigned Integer	1	0	ppm	ReadingRoom	CO
12	Enable	103_1	1	16-bit Unsigned Integer	1	0	ppm	ReadingRoom	CO2
13	Enable	103_1	2	16-bit Unsigned Integer	1	0	ug/m3	ReadingRoom	PM2.5
14	Enable	103_1	3	16-bit Unsigned Integer	0.01	0	%	ReadingRoom	Humidity
15	Enable	103_1	4	16-bit Signed Integer	0.01	0	°C	ReadingRoom	Temperature
16	Enable	104_1	0	16-bit Unsigned Integer	1	0	ppm	MultimediaCenter	CO
17	Enable	104_1	1	16-bit Unsigned Integer	1	0	ppm	MultimediaCenter	CO2
18	Enable	104_1	2	16-bit Unsigned Integer	1	0	ug/m3	MultimediaCenter	PM2.5
19	Enable	104_1	3	16-bit Unsigned Integer	0.01	0	%	MultimediaCenter	Humidity
20	Enable	104_1	4	16-bit Signed Integer	0.01	0	°C	MultimediaCenter	Temperature

« < 1 2 3 > »

Channel configuration for logging data from the reading room and multimedia center

#	Active	Group Name	Index Address	Data Type	Scale	Offset	Unit	Prefix	Alias
21	Enable	105_1	0	16-bit Unsigned Integer	1	0	ppm	StackRoom	CO
22	Enable	105_1	1	16-bit Unsigned Integer	1	0	ppm	StackRoom	CO2
23	Enable	105_1	2	16-bit Unsigned Integer	1	0	ug/m3	StackRoom	PM2.5
24	Enable	105_1	3	16-bit Unsigned Integer	0.01	0	%	StackRoom	Humidity
25	Enable	105_1	4	16-bit Signed Integer	0.01	0	°C	StackRoom	Temperature

« < 1 2 3 > »

3. Setting logging Interval

STEP 1: Move the DATA LOGGER page to the configuration section.

STEP 2: Select **Enable** from the “Logging Active” drop down menu and fill the required fields.

STEP 3: Click **SAVE** and restart the MDCL module.

After restarting, the MDCL will start logging data.

Logging Active

Enable

Logging Rate: 5 Seconds

Maximum Logging Period: Log to a new file after every 2 Hours

Data Log Overwrite: Stop logging when memory is full

Automatic File Upload: Do Not Upload File

[Set up the configuration for FTP server](#)

CANCEL SAVE

4. Downloading log files

STEP 1: Click **FILE MANAGER** on GENERAL SETTINGS page and click on the calendar icon.

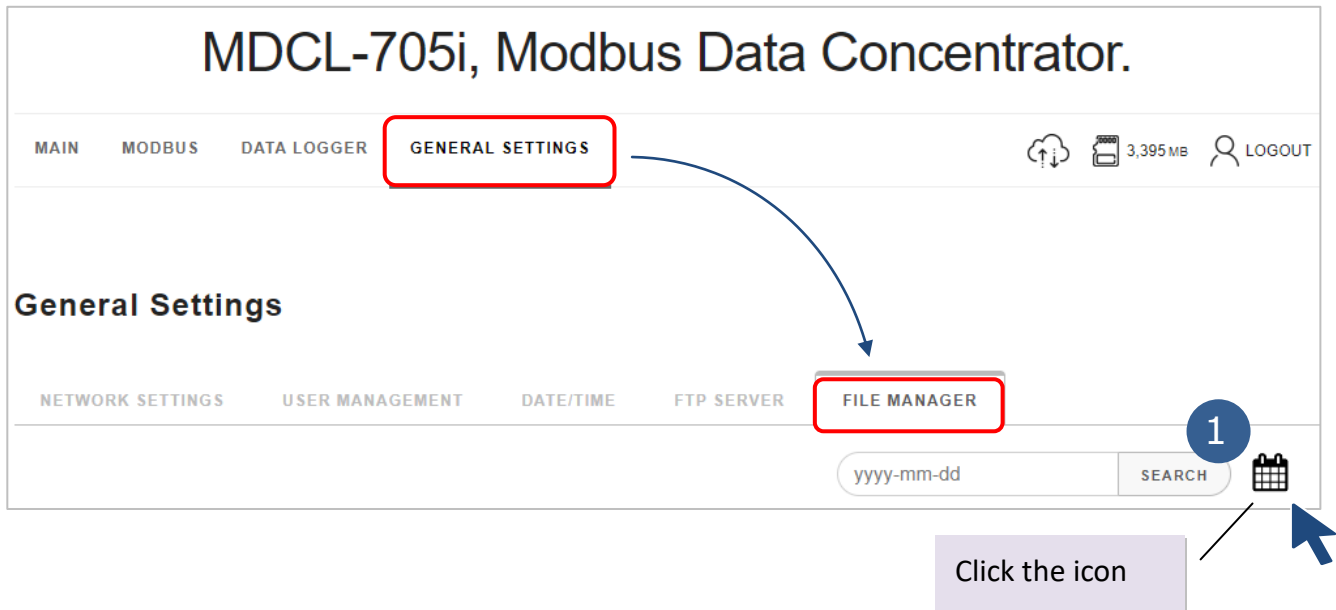

STEP 2: Select the date of the log files and click **SEARCH**.

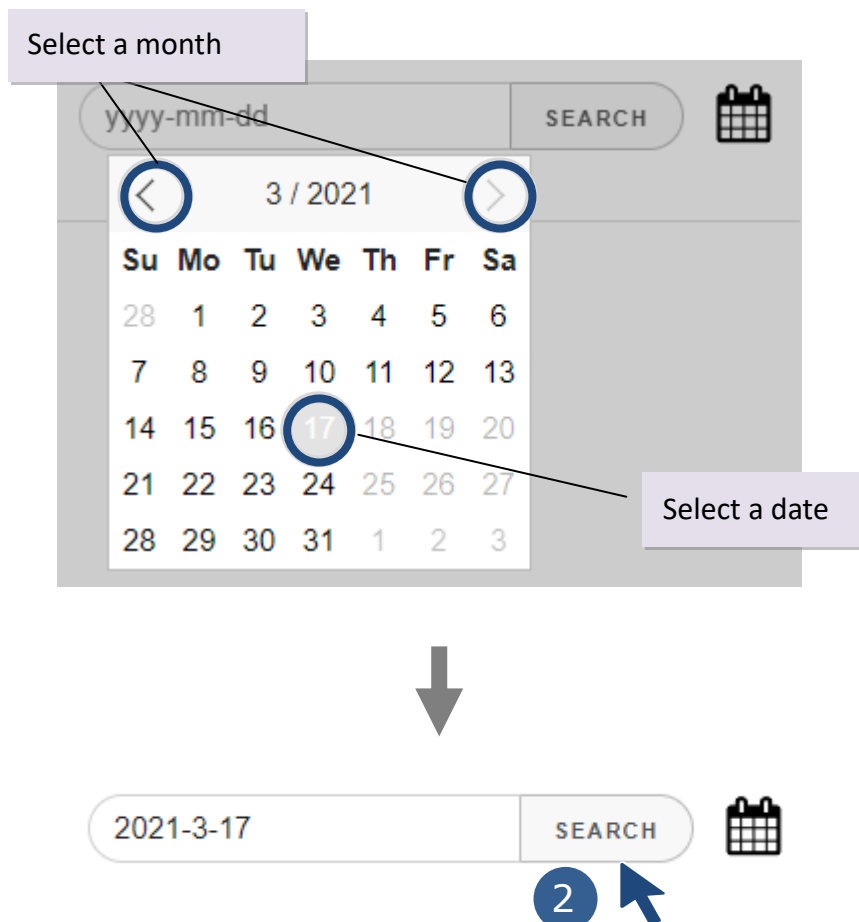

STEP 3: Click the DOWNLOAD icon for a file to download it.

NETWORK SETTINGS	USER MANAGEMENT	DATE/TIME	FTP SERVER	FILE MANAGER	
				2021-3-17	SEARCH
Date Created	Name	Size			
2021-03-17	T_031700.CSV	133,050	DOWNLOAD	DELETE	
2021-03-17	T_031702.CSV	133,050	DOWNLOAD	DELETE	
2021-03-17	T_031704.CSV	133,050	DOWNLOAD	DELETE	
2021-03-17	T_031706.CSV	133,050	DOWNLOAD	DELETE	
2021-03-17	T_031708.CSV	112,810	DOWNLOAD	DELETE	
5 file(s)		645,010 bytes			

STEP 4: Get the file in the default download directory of web browser..

2021-03-17	T_031706.CSV	133,050	DOWNLOAD	DELETE
2021-03-17	T_031708.CSV	112,810	DOWNLOAD	DELETE
5 file(s)		645,010 bytes		

T_031700.CSV	^
--------------	---

File name T_031700 created at 00:00:00, on March 17th

Each log file consists of a file header and log entries as shown below. The first 4 lines are header information including the MDCL firmware version, IP address, MAC address module name, and data type, unit and name for each channel. After that are logged entries with timestamps.

	A	B	C	D	E	F
1	ver1.0	10.1.112.10	00:0D:E0:FF:70:51	MDC-705i-DL		
2		UINT16[2]	UINT16[2]	UINT16[2]	UINT16[2]	INT16[1]
3		ppm	ppm	ug/m3	%	
4	DATETIME	Lobby.CO	Lobby.CO2	Lobby.PM2.5	Lobby.Humidity	
5	2021/3/17 00:00:00	0	410	0	53.36	26.12
6	2021/3/17 00:00:10	0	410	0	53.36	26.12
7	2021/3/17 00:00:20	0	411			
8	2021/3/17 00:00:30	0	411			
9	2021/3/17 00:00:40	0	411	0	53.38	26.14
10	2021/3/17 00:00:50	0	411	0	53.38	26.14
11	2021/3/17 00:01:00					26.14
12	2021/3/17 00:01:10					26.14
13	2021/3/17 00:01:20	0	410	0	53.37	26.11
14	2021/3/17 00:01:30	0	410	0	53.37	26.11
15	2021/3/17 00:01:40	0	410	0	53.37	26.11
16	2021/3/17 00:01:50	0	410	0	53.37	26.11
17	2021/3/17 00:02:00	0	410	0	53.37	26.11
18	2021/3/17 00:02:10	0	410	0	53.37	26.12

Firmware version, IP address, MAC address and module name

Data type and unit

Channel name by Prefix.Alias

Logging time starting on the hour (00:00)

8. Troubleshooting

In this chapter, we will explain how to troubleshoot the communication problems.

Possible causes of TIMEOUT

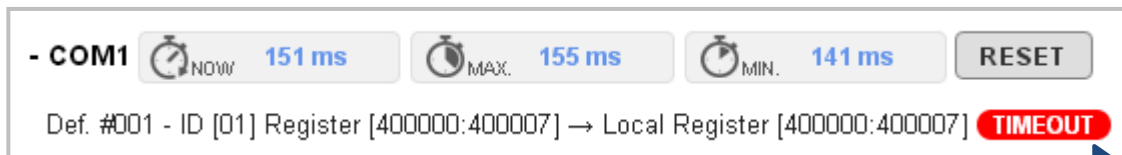

The screenshot shows a configuration panel for COM1. It includes three timer buttons: 'NOW' (151 ms), 'MAX.' (155 ms), and 'MIN.' (141 ms), each with a stopwatch icon. To the right is a 'RESET' button. Below these is a text field containing 'Def. #001 - ID [01] Register [400000:400007] → Local Register [400000:400007]'. A red 'TIMEOUT' button is highlighted with a blue arrow pointing to it from the right.

- **Situation #1:** The slave device is not active or the transfer function of the slave site may fail.

Solution: Check the slave device is powered up and the communication function is enabled.

- **Situation #2:** The COM port number to which the slave device is connected is not the same with the COM port number set in the polling definition.

Solution: Check if the COM port set in the polling definition is the same as the COM port connected to the device. If not, connect the slave device to the COM port number defined in the polling definition, or fix the **UseComPort** parameter to the virtual COM port number that the slave device is connected to.



This screenshot is identical to the one above, but the '- COM1' label is circled in red.

- **Situation #3:** The wiring for communication is wrong.

Solution: Exchange the D+ and D- wiring of RS-485 connection, and check the GND pin on the slave device is properly connected to the MDCL-705i.

- **Situation #4:** An incorrect Baud Rate or/and Data Format setting is specified.

Solution: Check if the Baud Rate, Data Format, Parity, and Stop Bits settings on the Modbus page are the same as the configuration of the slave device. If not, fix the difference between the settings on the web interface and the device configuration.

MAIN **MODBUS** DATA LOGGER GENERAL SETTINGS

COM1 COM2 COM3 COM4 COM5

Operation Mode
Modbus Master

Baud Rate: 9600 bps Data Bits: 8 Bits Parity: None Parity Stop Bits: 1 Stop Bit

Delay Between Polls (ms): 20 Timeout (ms): 50 Retry Times: 2

CANCEL SAVE

- **Situation #5:** An incorrect ID of the Modbus slave device is specified.

Solution: Check and fix the ID number in the polling definition.

- COM1 NOW 151 ms MAX. 155 ms MIN. 141 ms RESET

Def. #001 - ID [01] Register [400000:400007] → Local Register [400000:400007] **TIMEOUT**

- **Situation #6:** The value set for **Delay Between Polls** or **Timeout** is not long enough.

Solution: Lengthen the **Delay Between Polls** or **Timeout** setting until it is suitable for communication with the slave device.

The screenshot displays the MODBUS configuration interface. At the top, there are navigation tabs: MAIN, MODBUS (highlighted with a red circle), DATA LOGGER, and GENERAL SETTINGS. On the right, there are icons for a cloud, a battery level indicator at 29,596 uB, and a user icon with the text LOGOUT. Below the navigation, there are tabs for COM1, COM2, COM3, COM4, and COM5. The main configuration area includes:

- Operation Mode: Modbus Master (dropdown)
- Baud Rate: 9600 bps (dropdown)
- Data Bits: 8 Bits (dropdown)
- Parity: None Parity (dropdown)
- Stop Bits: 1 Stop Bit (dropdown)
- Delay Between Polls (ms): 20 (input field, highlighted with a red box)
- Timeout (ms): 50 (input field, highlighted with a red box)
- Retry Times: 2 (input field)

At the bottom, there are CANCEL and SAVE buttons.

9. FAQ

Q1: What are the maximum numbers of polling definition and local register?

A1: The maximum number of polling definition in a MDCL-705i is 250, each definition can access up to 125 registers. Each of the four tables (DI/DO/AI/DO) can store up to 9600 registers of data.

Q2: What is the maximum number of registers can be accessed in one Modbus command from a Modbus master device?

A2: By following the Modbus protocol, the maximum amount of registers that one command can access is 255 of function code 01 and 02, and 126 of function code 03 and 04.

Q3: How are the local registers mapped to the polled data in a MDCL-705i?

A3: Only the function code 01/02/03/04 can be used in the polling definition section in config.csv.

- 01: Read Coil Status (Read DO)
- 02: Read Input Status (Read DI)
- 03: Read Holding Registers (Read AO)
- 04: Read Input Registers (Read AI)

Use the environmental monitoring application in section 6.4 as an example:

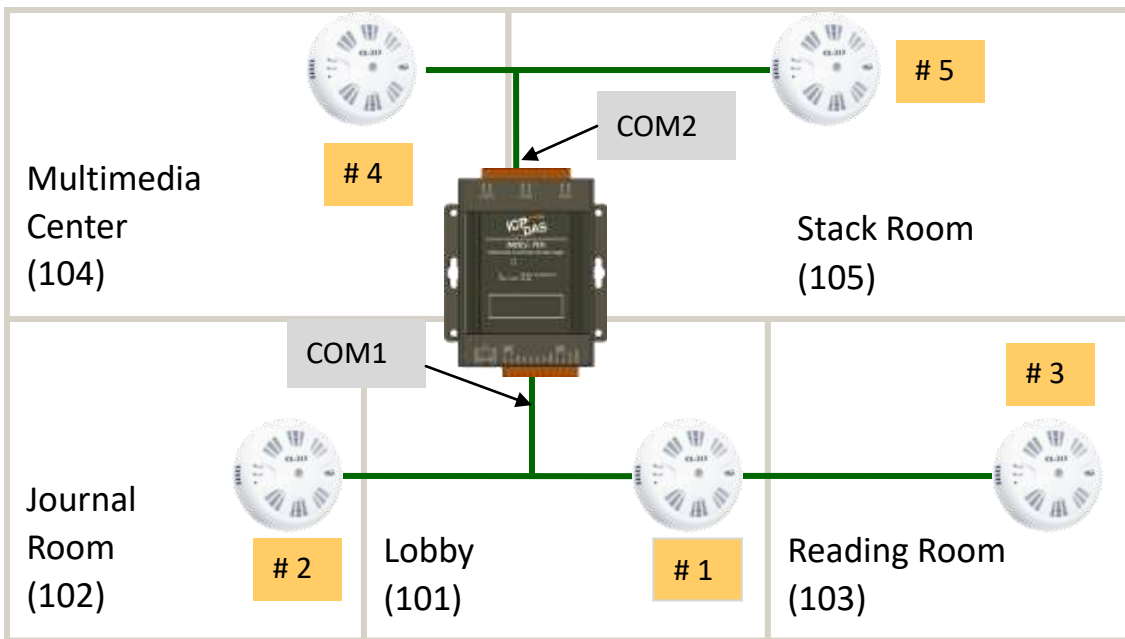

Config.csv

	A	B	C	D	E	F	G	H	I	J
1	#	UseComPort	SlaveModbusID	FunctionCode	RegStartAddr	RegCount	TimeoutEventProcess	PresetValue	GroupName	Description
2	*	1	1	4	0	5	2	65535	101_1	Lobby Data
3	*	1	1	3	452	1	2	65535	101_2	Lobby Offset
4	*	1	1	1	304	5	0	0	101_3	Lobby Alarm
5	*	1	2	4	0	5	2	65535	102_1	JournalR Data
6	*	1	2	3	452	1	2	65535	102_2	JournalR Offset
7	*	1	2	1	304	5	0	0	102_3	JournalR Alarm
8	*	1	3	4	0	5	2	65535	103_1	ReadR Data
9	*	1	3	3	452	1	2	65535	103_2	ReadR Offset
10	*	1	3	1	304	5	0	0	103_3	ReadR Alarm
11	*	2	4	4	0	5	2	65535	104_1	MC Data
12	*	2	4	3	452	1	2	65535	104_2	MC Offset
13	*	2	4	1	304	5	0	0	104_3	MC Alarm
14	*	2	5	4	0	5	2	65535	105_1	StackR Data
15	*	2	5	3	452	1	2	65535	105_2	StackR Offset
16	*	2	5	1	304	5	0	0	105_3	StackR Alarm

Scan sequence and mapped register addresses

Mapped register addresses

The interface displays two communication channels, COM1 and COM2, each with a list of register definitions. Each definition includes a definition ID, ID, Register address, Local Register address, a status (GOOD), and a corresponding data/offset/alarm button. Performance metrics (NOW, MAX, MIN) and a RESET button are shown for each channel.

Channel	Def. #	ID	Register	Local Register	Status	Action
COM1	#001	[01]	[300000:300004]	[300000:300004]	GOOD	Lobby Data
	#002	[01]	[400452:400452]	[400000:400000]	GOOD	Lobby Offset
	#003	[01]	[000304:000308]	[000000:000004]	GOOD	Lobby Alarm
	#004	[02]	[300000:300004]	[300005:300009]	GOOD	JournalR Data
	#005	[02]	[400452:400452]	[400001:400001]	GOOD	JournalR Offset
	#006	[02]	[000304:000308]	[000005:000009]	GOOD	JournalR Alarm
	#007	[03]	[300000:300004]	[300010:300014]	GOOD	ReadR Data
	#008	[03]	[400452:400452]	[400002:400002]	GOOD	ReadR Offset
	#009	[03]	[000304:000308]	[000010:000014]	GOOD	ReadR Alarm
COM2	#010	[04]	[300000:300004]	[300015:300019]	GOOD	MC Data
	#011	[04]	[400452:400452]	[400003:400003]	GOOD	MC Offset
	#012	[04]	[000304:000308]	[000015:000019]	GOOD	MC Alarm
	#013	[05]	[300000:300004]	[300020:300024]	GOOD	StackR Data
	#014	[05]	[400452:400452]	[400004:400004]	GOOD	StackR Offset
	#015	[05]	[000304:000308]	[000020:000024]	GOOD	StackR Alarm

Scan sequence

The scan sequence will follow the order of polling definitions defined in the config.csv, as well as the data collected from different devices will be placed in consecutive addresses according to their type. The mapped register addresses of the data can be illustrated as shown below.

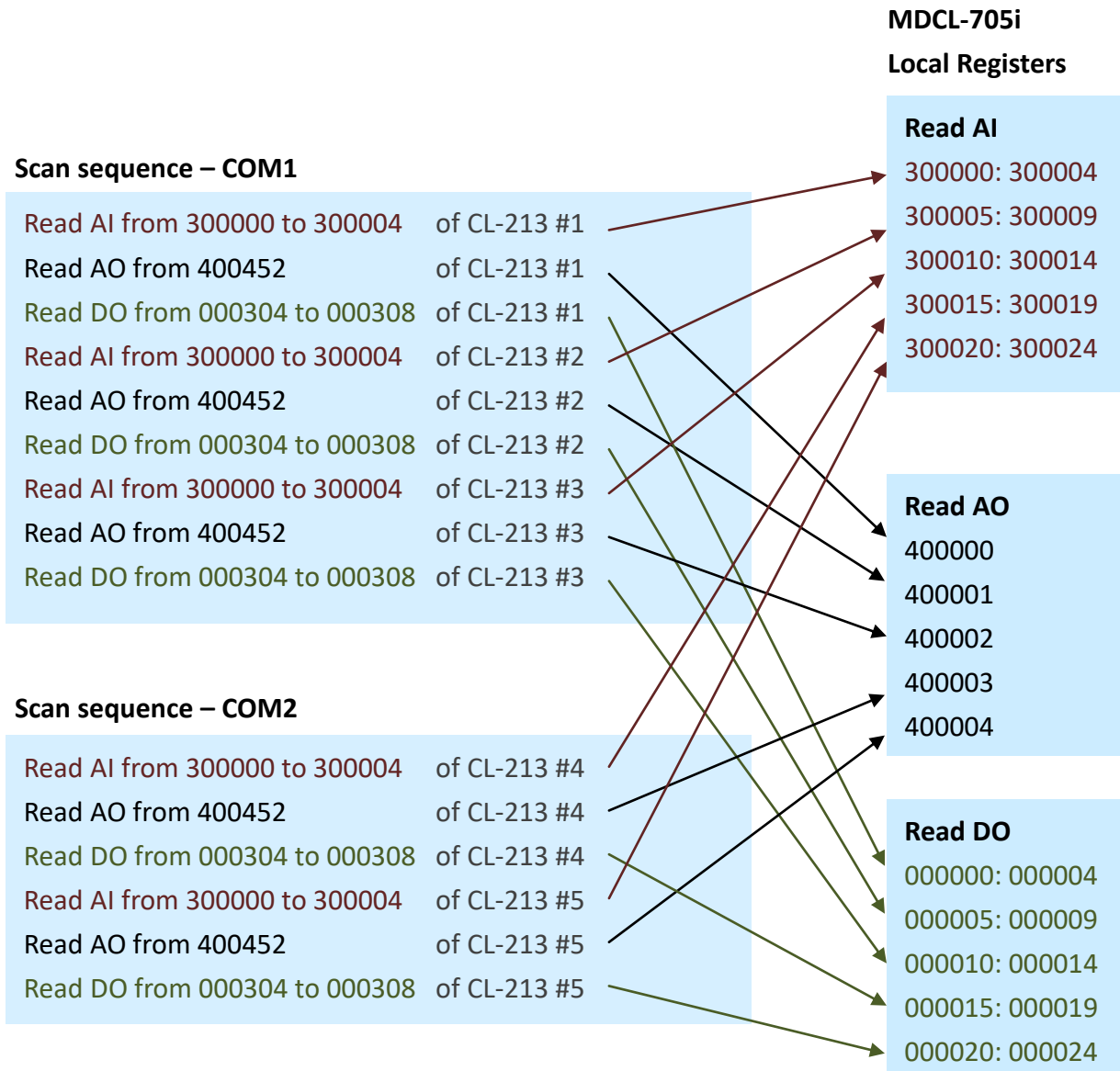

Q4: How to write data to output channels on a Modbus RTU slave device?

A4: Let's continue the example in Q3, the polling definition for the output channels with read function code are edited in the config.csv file and the config.csv file are imported. Now we have the local register addressed for the output channels on the Modbus RTU slave device.

Modbus TCP client or Modbus RTU master can write data to an output channel by writing data to the local register address mapped for the channel.

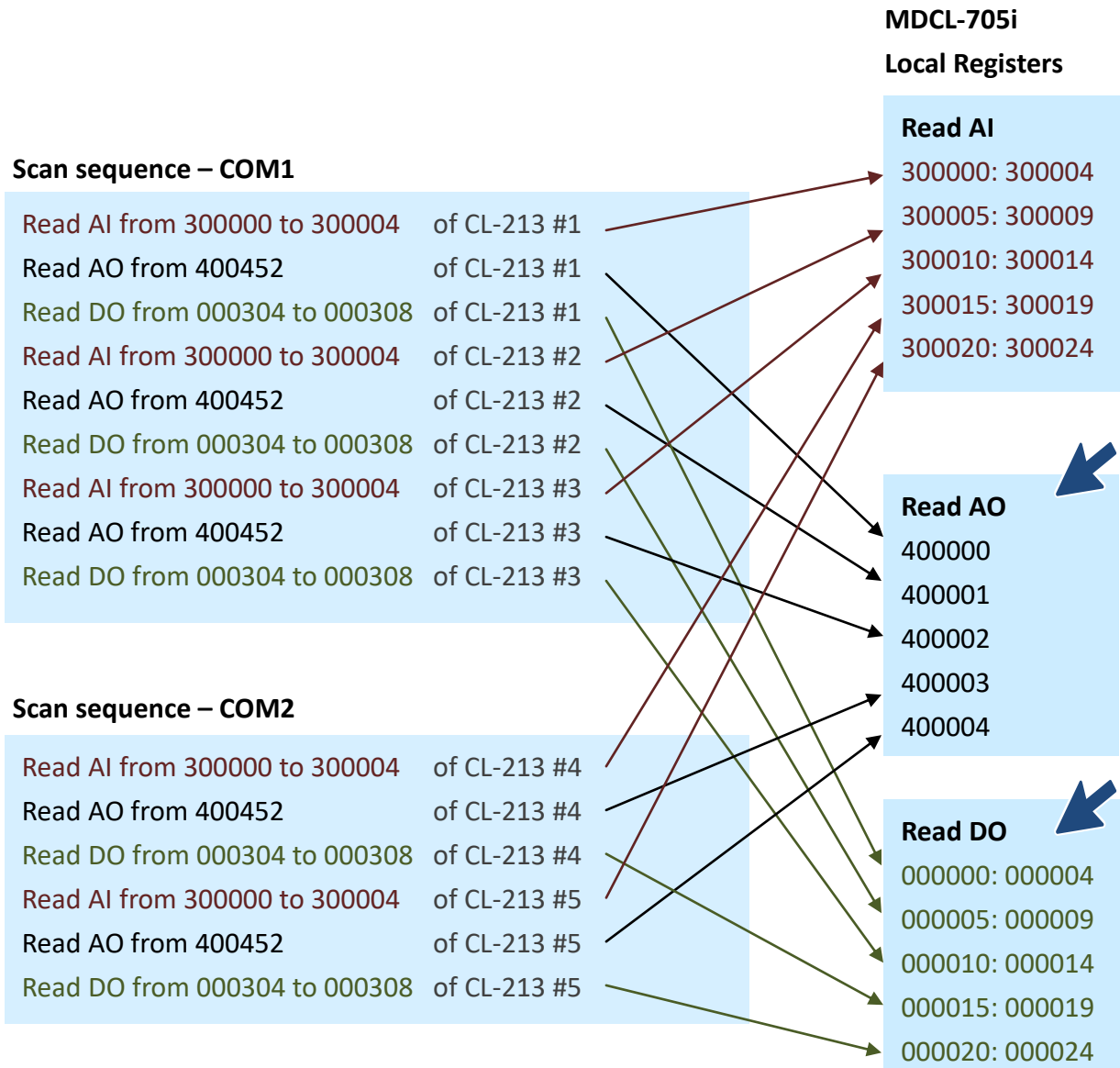

Q5: How to read the status of each connection?

A5: The status for each connection is saved as the sequence of polling definition from local register address 39600. The maximum number of polling definition in the config.csv file is 250, so the available address for the connection status is from 39600 to 39849. Function code 04 can be used to read the status and up to 126 register of status can be read in one command.

For example, use Function code 04 to read data from 39600 to 39605, the connection status of polling definition 001 to 006 may be read as the third column in the following table. 0 indicates the connection status is good and 0xFFFF indicates that the connection is timeout.

Def. number	Address	Status	Status display on web page
Def.#001	39600	0	GOOD
Def.#002	39601	0	GOOD
Def.#003	39602	0xFFFF	TIMEOUT
Def.#004	39603	0x8201	ERROR: ILLEGAL FUNCTION
Def.#005	39604	0	GOOD
Def.#006	39605	0x8402	ERROR: ILLEGAL DATA ADDRESS

The value of status:

0: Good

0xFFFF: Timeout

0x8XY: Exception response. **X** - Modbus Function Code. **YY** - Exception Code.

Exception Code	Name	Description
01	Illegal Function	The function code received is not an allowable action.
02	Illegal Data Address	The data address received in the query is not an allowable address.
03	Illegal Data Value	A value contained in the query data field is not an allowable value.
04	Illegal response length	The request would generate a response with size bigger than that available for MODBUS protocol.

Q6: How to show timestamps with seconds in Excel?

A6: If you open a log file in Excel and see ##### in **DATETIME** line, simply increase the width of the column to make the data visible.



	A	B	C	D	E	F
1	ver1.0	10.1.112.10	00:0D:E0:FF:70:51	MDC-705i-DL		
2		UINT16[2]	UINT16[2]	UINT16[2]	UINT16[2]	INT16[1]
3		ppm	ppm	ug/m3	%	°C
4	DATETIME	Lobby.CO	Lobby.CO2	Lobby.PM2.5	Lobby.Humidity	Lobby.Temperature
5	#####	0	410	0	53.36	26.12
6	#####	0	410	0	53.36	26.12
7	#####	0	411	0	53.36	26.12
8	#####	0	411	0	53.38	26.14
9	#####	0	411	0	53.38	26.14
10	#####	0	411	0	53.38	26.14
11	#####	0	410	0	53.38	26.14
12	#####	0	410	0	53.37	26.14
13	#####	0	410	0	53.37	26.11

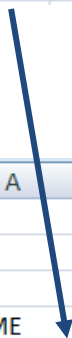

	A	B	C	D	E	F
1	ver1.0	10.1.112.10	00:0D:E0:FF:70:51	MDC-705i-DL		
2		UINT16[2]	UINT16[2]	UINT16[2]	UINT16[2]	INT16[1]
3		ppm	ppm	ug/m3	%	°C
4	DATETIME	Lobby.CO	Lobby.CO2	Lobby.PM2.5	Lobby.Humidity	Lobby.Temperature
5	2021/3/17 00:00	0	410	0	53.36	26.12
6	2021/3/17 00:00	0	410	0	53.36	26.12
7	2021/3/17 00:00	0	411	0	53.36	26.12
8	2021/3/17 00:00	0	411	0	53.38	26.14
9	2021/3/17 00:00	0	411	0	53.38	26.14
10	2021/3/17 00:00	0	411	0	53.38	26.14
11	2021/3/17 00:01	0	410	0	53.38	26.14
12	2021/3/17 00:01	0	410	0	53.37	26.14
13	2021/3/17 00:01	0	410	0	53.37	26.11

Excel formats times without seconds by default, so we need to change the formatting of the column **DATETIME** according to the pattern “yyyy/m/d hh:mm:ss” to see the seconds.

Here are the step-by-step instructions.

Step 1: Mark the **DATETIME** line, and select **Format Cells** option on the right-click menu.

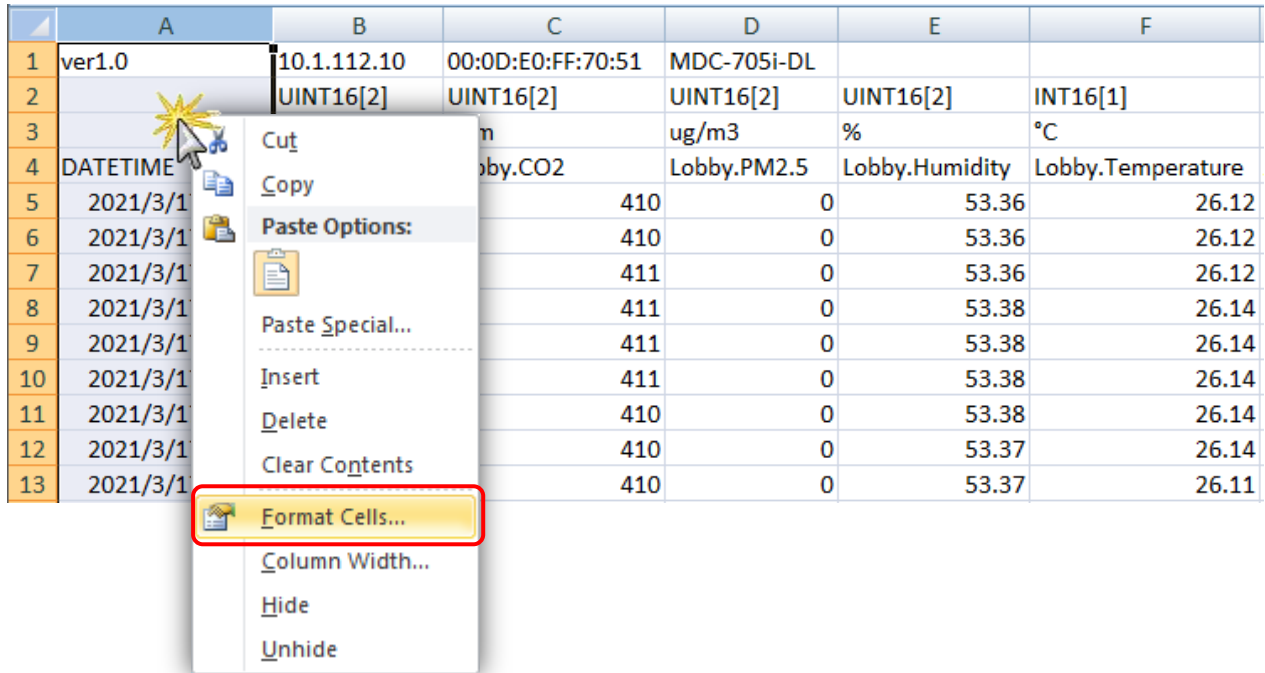

Step 2: Click **Custom** in the Category field and select **yyyy/m/d hh:mm** in Type field.

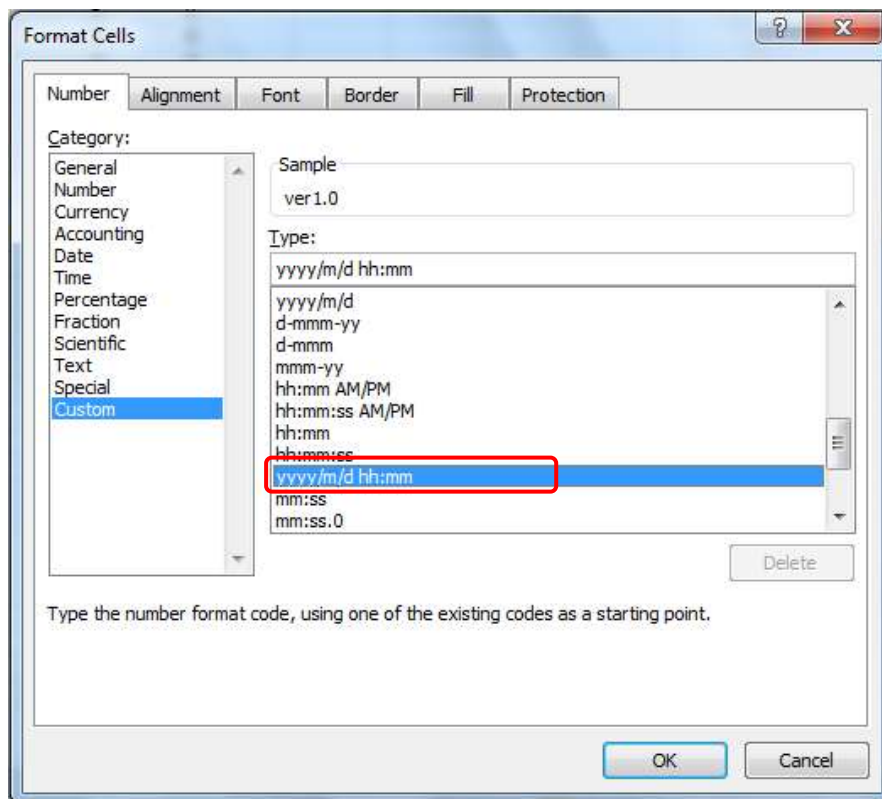

Step 3: Add :ss at the end of yyyy/m/d hh:mm and click OK.

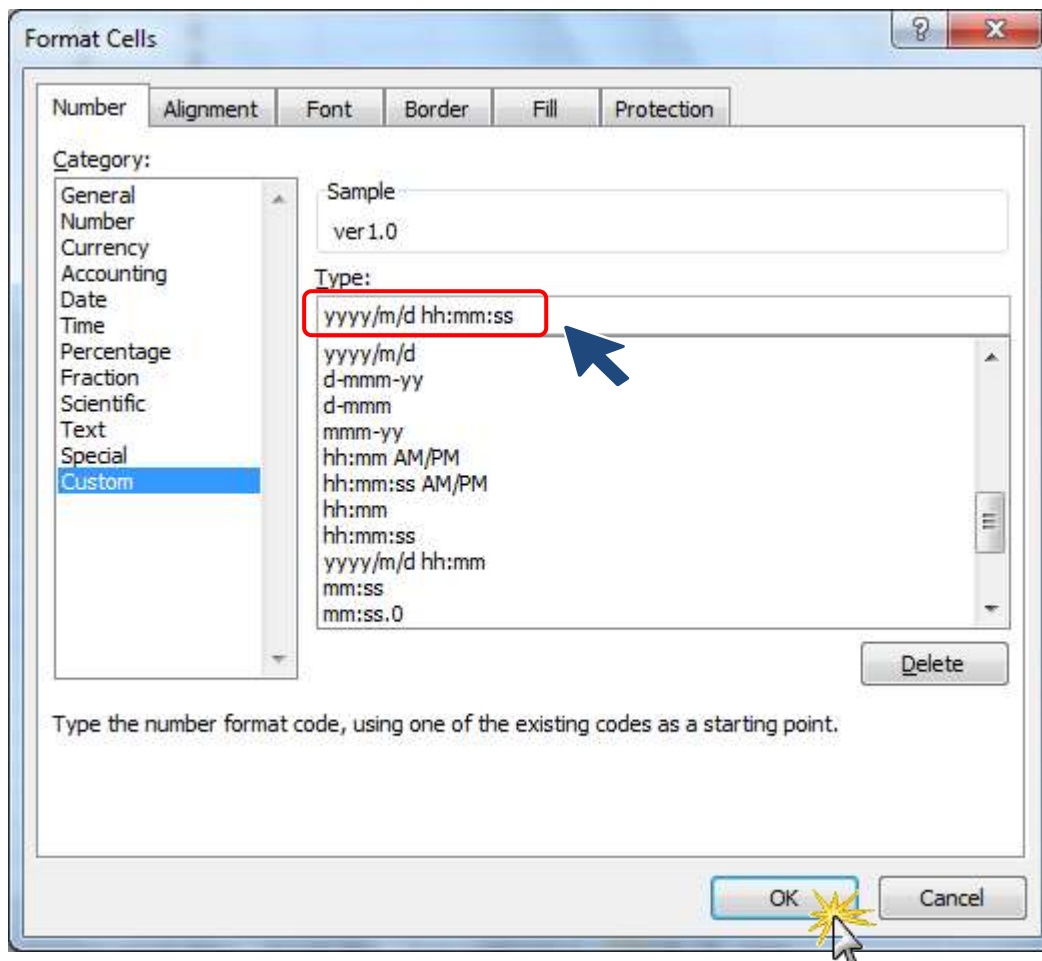

Now the seconds are displayed in the timestamps.

	A	B	C	D	E	F
1	ver1.0	10.1.112.10	00:0D:E0:FF:70:51	MDC-705i-DL		
2		UINT16[2]	UINT16[2]	UINT16[2]	UINT16[2]	INT16[1]
3		ppm	ppm	ug/m3	%	°C
4	DATETIME	Lobby.CO	Lobby.CO2	Lobby.PM2.5	Lobby.Humidity	Lobby.Temperature
5	2021/3/17 00:00:00	0	410	0	53.36	26.12
6	2021/3/17 00:00:10	0	410	0	53.36	26.12
7	2021/3/17 00:00:20	0	411	0	53.36	26.12
8	2021/3/17 00:00:30	0	411	0	53.38	26.14
9	2021/3/17 00:00:40	0	411	0	53.38	26.14
10	2021/3/17 00:00:50	0	411	0	53.38	26.14
11	2021/3/17 00:01:00	0	410	0	53.38	26.14
12	2021/3/17 00:01:10	0	410	0	53.37	26.14
13	2021/3/17 00:01:20	0	410	0	53.37	26.11

Revision History

Revision	Date	Description
1.0.1	2025/06	Modified the descriptions for FTP server support, user account creation, and firmware download via the web interface.
1.0.0	2021/06	First released