

---

# *The I-7531-FD / I-7531-FD-UTA CAN Repeater*

## User Manual

### **Warranty**

All products manufactured by ICP DAS are under warranty regarding defective materials for a period of one year from the date of delivery to the original purchaser.

### **Warning**

ICP DAS assumes no liability for damages resulting from the use of this product. ICP DAS reserves the right to change this manual at any time without notice. The information furnished by ICP DAS is believed to be accurate and reliable. However, no responsibility is assumed by ICP DAS for its use, or for any infringements of patents or other rights of third parties resulting from its use.

### **Copyright**

Copyright 2021 by ICP DAS. All rights are reserved.

### **Trademark**

The names used for identification only may be registered trademarks of their respective companies.

---

# Tables of Content

Tables of Content.....	2
1 Introduction.....	3
1.1 Features.....	4
1.2 Specifications .....	4
2 Technical data .....	6
2.1 Block Diagram.....	6
2.2 Appearance .....	7
2.3 Pin Assignment.....	8
2.4 Wire Connection .....	10
2.5 Status LED.....	10
2.6 Terminator Resistor Setting .....	11
2.7 Baud rate and wire length of CAN bus.....	13
3 Dimension .....	15

---

# 1 Introduction

The I-7531-FD series are isolated CAN/CAN FD signal repeaters with two CAN ports that can connect and isolate two CAN signals with the same CAN baud rate. When the CAN signal received by one of the CAN ports is attenuated due to cable length or noise interference, this module can restore the CAN signal to its original shape and output it from the other CAN port. Additionally, the module can automatically adjust its CAN baud rate to match the CAN bus, so users do not need to configure any module parameters. Users only need to connect the module to the CAN bus, supply power, and it will function normally.

However, please note that although the attenuated CAN signal can be restored to its original shape after passing through this module, there will be a slight time delay at the physical layer, and the communication distance of the CAN signal will not be extended, please refer to section 2.7 for detailed instructions.

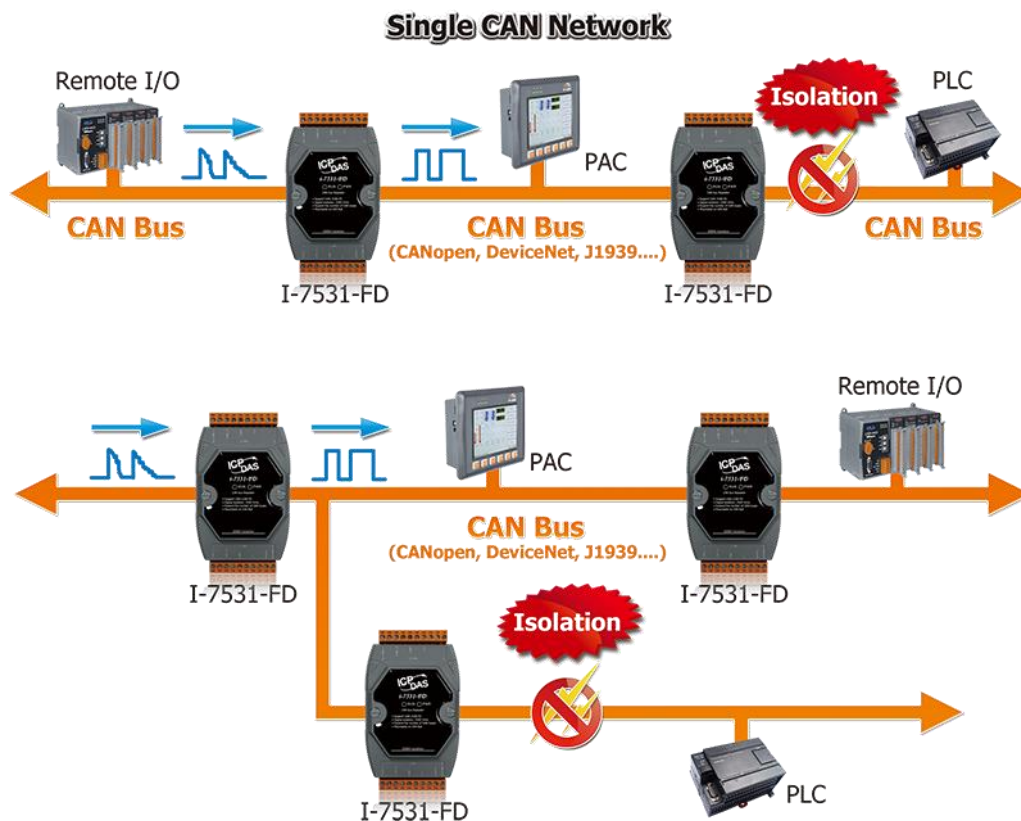

Figure1. Application

---

## 1.1 Features

- Supported CAN specification 2.0A/B and CAN FD
- Fully compatible with the ISO 11898-2 standard
- Detected CAN bus baud rate automatically, maximum support 8000 kbps
- Wide Operating Temperature Range:
  - Standrd Series: -25 ~ +75°C
  - UTA Series: -40 ~ +75°C

## 1.2 Specifications

Module Name	I-7531-FD	I-7531-FD-UTA
CAN		
Ports	2	
Baud Rate	CAN bus: 5 k ~ 800 kbps CAN FD: Arbitration rate up to 1000 kbps, data rate up to 8000 kbps (Note) The data rates are verified by tests, but user-defined baud rates are possible, so the maximum data rate will depend on the concrete operating conditions (cable length, remote stations, etc.).	
Isolation	2500 Vrms for digital isolation, and 3000 V for DC-DC	
Terminal Resistor	Build in 120 Ω terminal resistor and support jumper to select	
Specification	ISO-11898-2, CAN 2.0A/B and CAN FD (CAN FD support ISO and Non-ISO standards)	
Time Delay	Typ. 175ns (corresponds to ~35m CAN bus length)	
Power		
Input Range	+10 VDC ~ +30 VDC	

Power		
Consumption	1 W	
Mechanical		
Casing	Plastic	
Dimensions (mm)	72 x 118 x 33 (W x L x H)	
Installation	DIN-Rail	
Environmental		
Operating Temperature	-25°C ~ +75°C	-40°C ~ +75°C
Storage Temperature	-30°C ~ +80°C	-40°C ~ +80°C
Humidity	10 ~ 90% RH, Non-condensing	

---

## 2 Technical data

### 2.1 Block Diagram

Figure 2 is a block diagram illustrating the functions of the I-7531-FD module. Power supply are with 3000 V<sub>DC</sub> galvanic isolated between each CAN port. Furthermore, there is digital-isolation 2500 V<sub>rms</sub> between two CAN ports.

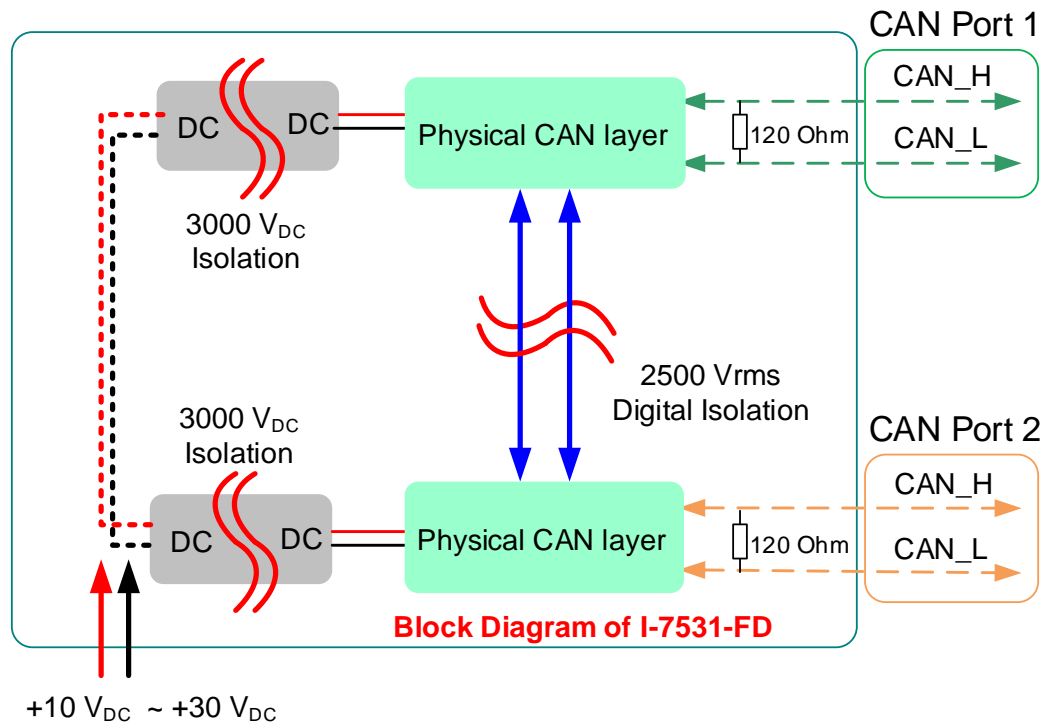

Figure2. Block Diagram

## 2.2 Appearance

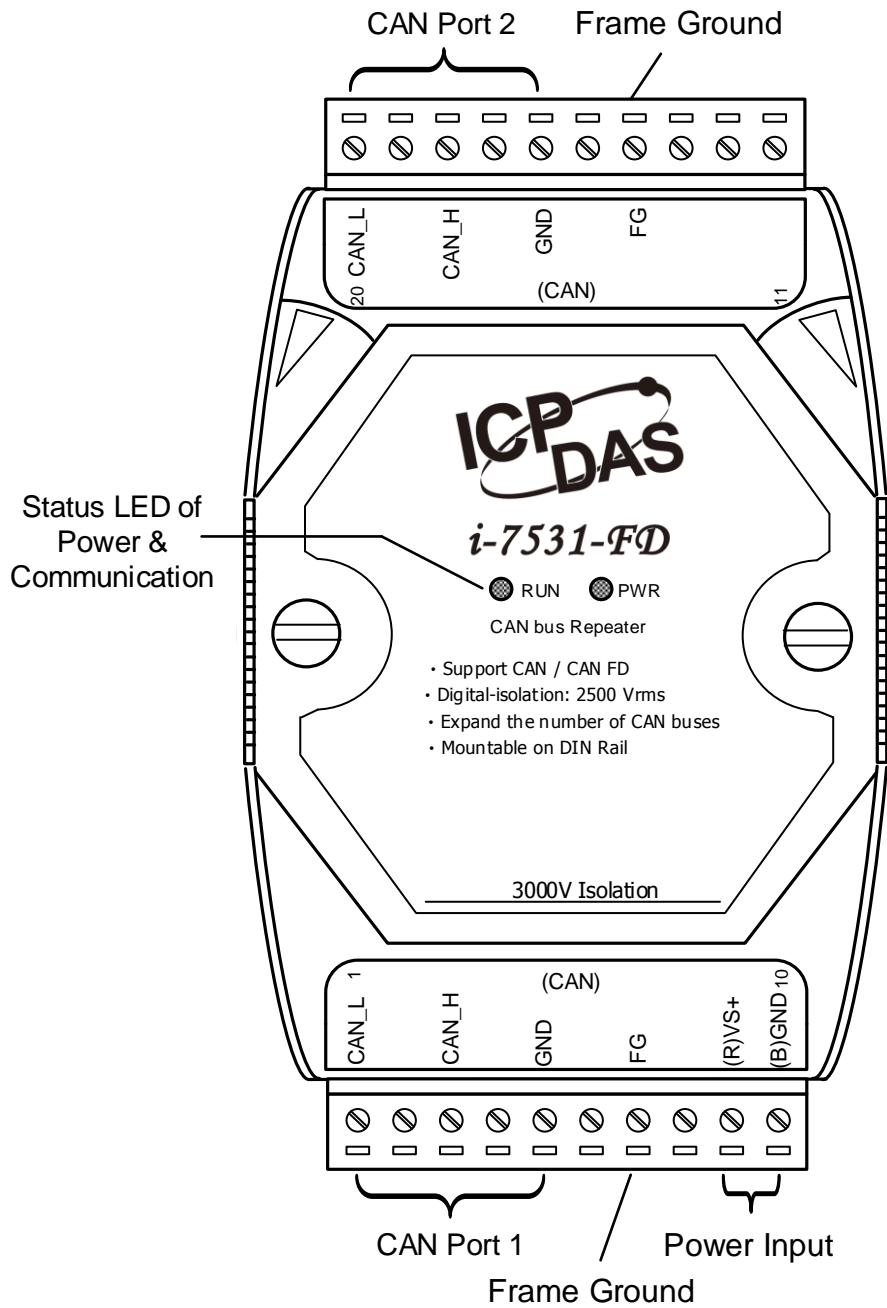

Figure3. Appearance

## 2.3 Pin Assignment

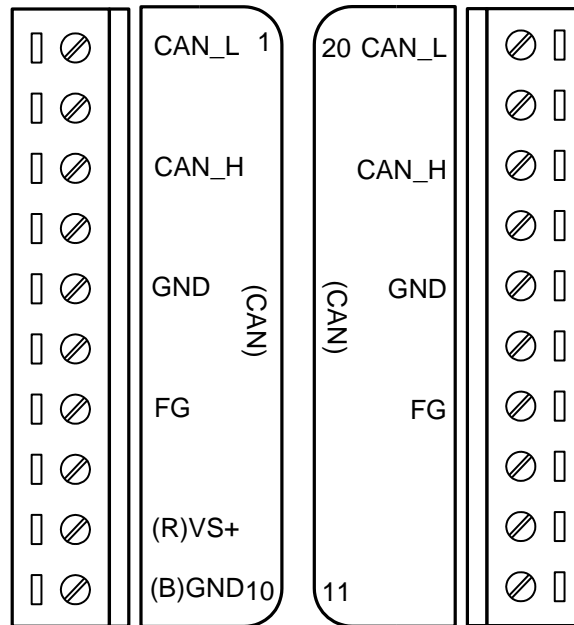

Figure4. Pin Assignment

Table1. Pin Description

Pin	Name	Description
1	CAN_L	CAN_Low. Signal Line of CAN port 1.
3	CAN_H	CAN_High. Signal Line of CAN port 1.
5	GND	CAN_Ground (or CAN_GND), voltage level of ground of CAN_L and CAN_H in CAN port 1.
7	FG	Frame Groud.
9	(R)VS+	Power input +10VDC ~ +30VDC.
10	(B)GND	
14	FG	Frame Groud.
16	GND	CAN_Ground (or CAN_GND), Voltage level of ground of CAN_L and CAN_H in CAN port 2.
18	CAN_H	CAN_High. Signal Line of CAN port 2.
20	CAN_L	CAN_Low. Signal Line of CAN port 2.

---

Note 1: In normal situation, the CAN\_GND does not need to be wired, but the CAN\_GND's voltage level of different CAN devices are not equal in some case. When in this situation, it maybe cause some problems and reduce the stability of the CAN bus system. The user can connect CAN\_GND of these CAN devices to let the voltage level be same and eliminate this situation.

Note 2: Electronic circuits are susceptible to electrostatic discharge (ESD) and will get worse when encountering continental climates, so F.G. provides a path for ESD to lead to the earth ground, thereby enhancing the module's ability to protect against static electricity. If the user wants to use F.G., both pin 7 and pin 14 need to be connected to the earth ground, because the two pins are not connected inside the module.

## 2.4 Wire Connection

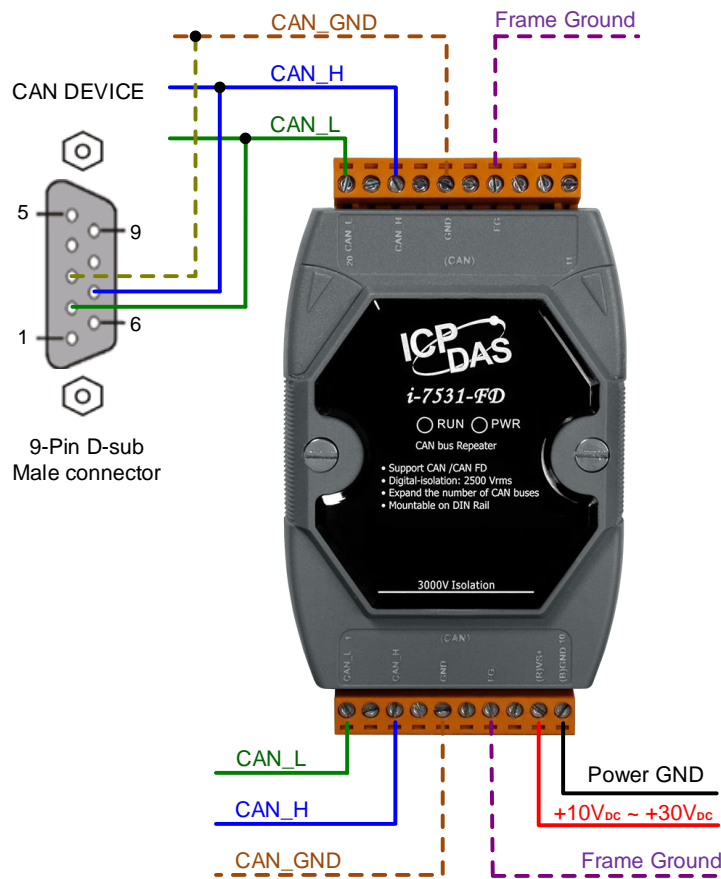
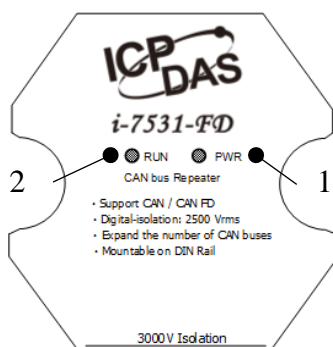

Figure5. Wire Connection

## 2.5 Status LED



LED	Color	Status	Description
1 (PWR)	Red	ON	Power on
		OFF	Power off
2 (RUN)	Green	Blink	In communication
		OFF	No data in communication

Note: RUN LED's twinkling rate correlates with baud rate of CAN bus. User may see no twinkling when the twinkling period is too short because of the higher baud rate of CAN bus. Besides, the LED could look like always on when bus loading is heavy.

---

## 2.6 Terminator Resistor Setting

According to the ISO 11898-2 specifications, the bus line of CAN\_H and CAN\_L must be terminated by resistor for proper operation. The equivalent resistance between CAN\_H and CAN\_L should be 60Ω. There are some examples below.

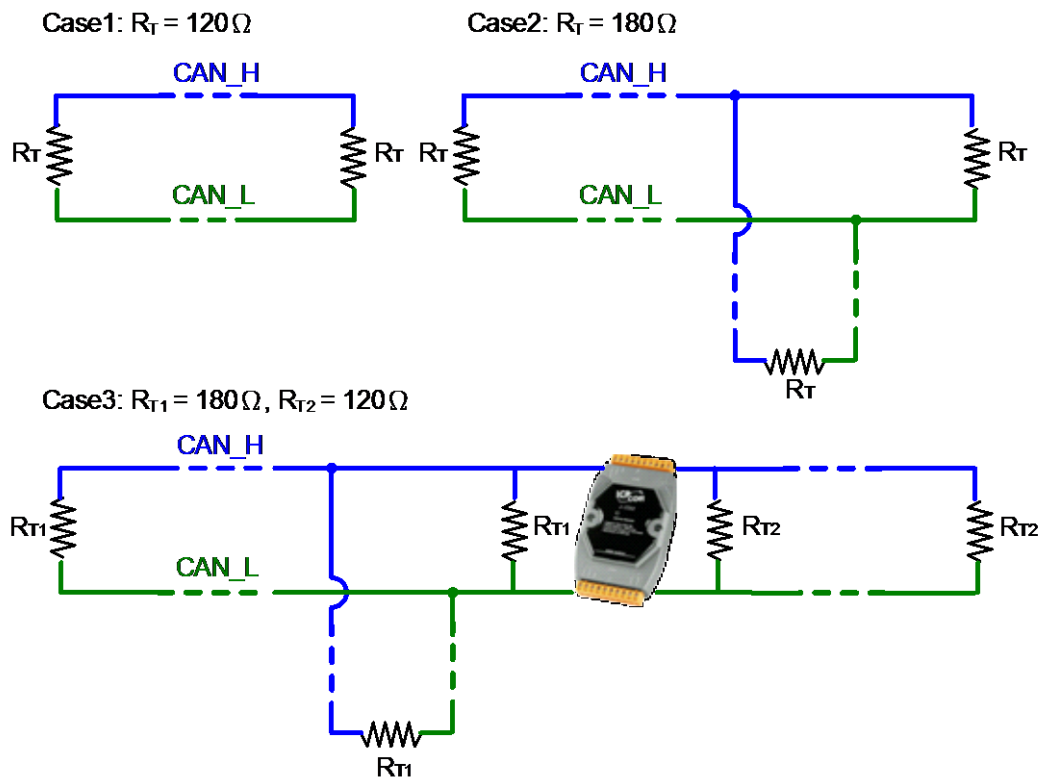

Figure6. Terminator Resistor

---

On the other hand, the I-7531-FD module has built-in two 120Ω terminating resistors, and the user can use the jumper to select whether to enable it. Among them, JP1 is used to adjust the terminal resistance of CAN port 1, and JP2 is used to adjust the terminal resistance of CAN port 2. If the user wants to adjust the terminal resistance, who needs to open the casing of I-7531-FD, and will see the positions of JP1 and JP2 as shown in the figure below:

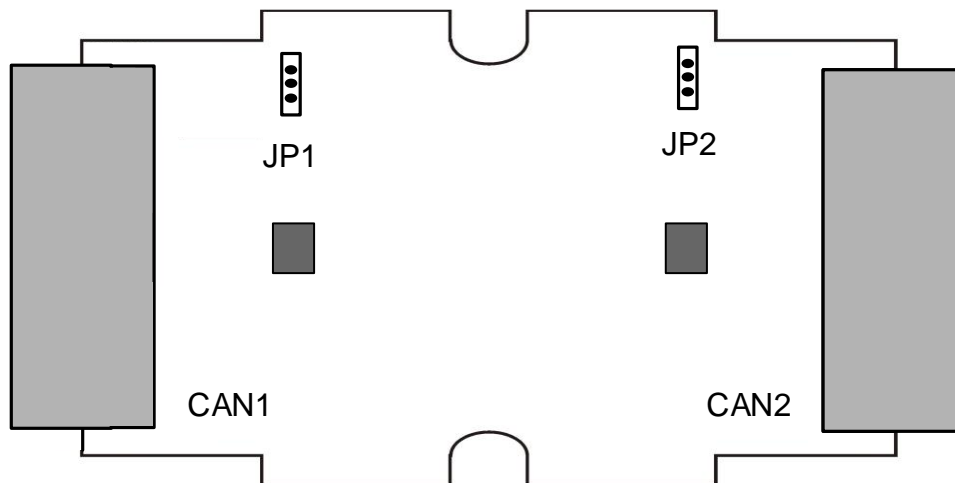

Figure7. JP1 and JP2 positions

The following connection statuses present the condition if the terminal resistor is enabled (default) or disabled.

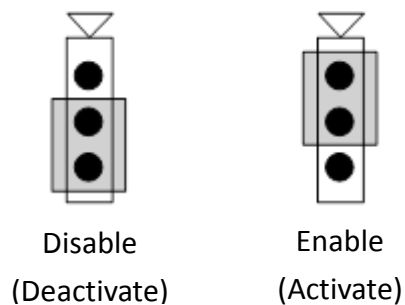

Figure8. Adjustment of Terminator Resistor

---

## 2.7 Baud rate and wire length of CAN bus

The CAN bus is a balanced (differential) 2-wire interface running over either a Shielded Twisted Pair (STP), Un-shielded Twisted Pair (UTP), or Ribbon cable. However, the baud rate of communication is inversely proportional to the wire length. When the baud rate is lower, the ideal CAN bus wire length that can be used is longer, as shown in the following table.

(Note: The ideal CAN bus wire length means the sum of the wire lengths of each CAN bus in a single CAN network.)

Table2. Baud rate and ideal CAN bus wire length

<b>Baud rate [bit/sec]</b>	<b>Ideal CAN bus wire length [meters]</b>
800K	50
500K	100
250K	250
125K	500
50K	1000
20K	2500
10K	5000

In addition, the I-7531-FD can isolate and re-amplify the CAN bus signal, so the user will think that connecting multiple I-7531-FDs in series on the same CAN bus, the CAN bus signal will always re-amplify and then extend the wire length of CAN bus, but the CAN bus signal passing through the I-7531-FD will reduce the ideal CAN wire length due to the time delay at the physical layer in fact.

In other words, when the user add one I-7531-FD to the CAN bus, the CAN signal passing through the I-7531-FD will be delayed by 175ns, and the ideal CAN bus wire length will be reduced by 35 meters.

For example, the baud rate used by the user is 500Kbps, and the ideal CAN bus wire length is 100 meters, when one I-7531-FD is connected in series to the CAN bus, the ideal CAN bus wire length will be reduced by 35 meters that is reduced from 100 meters to 65 meters ( $100 - 35 \times 1 = 65$ ).

By analogy, if two I-7531-FDs are connected in series on the CAN bus, it will reduced by  $35 \times 2 = 70$  meters as shown in the below figure.

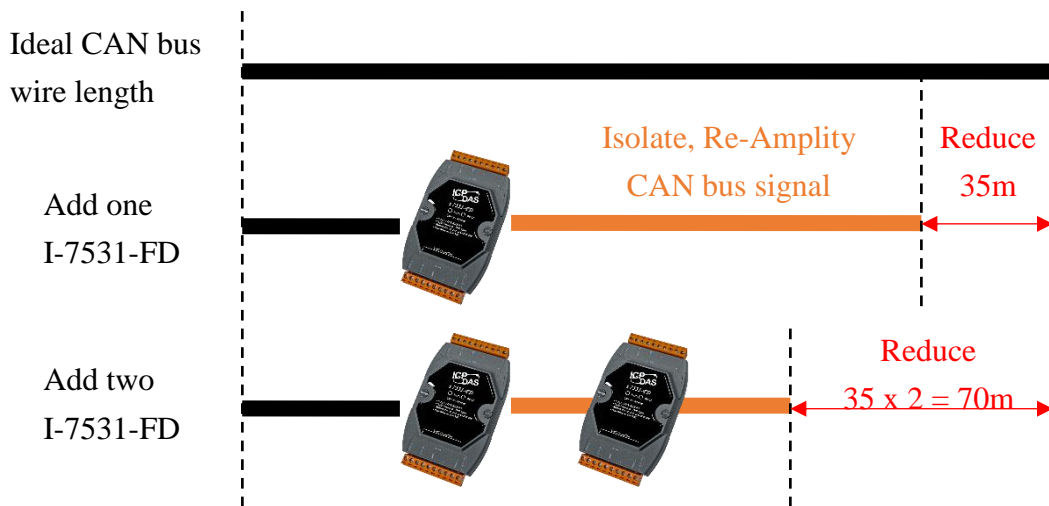

Figure9. Differences after adding I-7531-FD

Therefore, the baud rate and the maximum number of I-7531-FD supported by a single CAN bus are shown in the following table.

Table3. The number of I-7531-FD supported by a single CAN bus

Baud rate [bit/sec]	The number of I-7531-FD supported by a single CAN bus
800K	1
500K	2
250K	7
125K	14
50K	28
20K	71
10K	142

---

### 3 Dimension

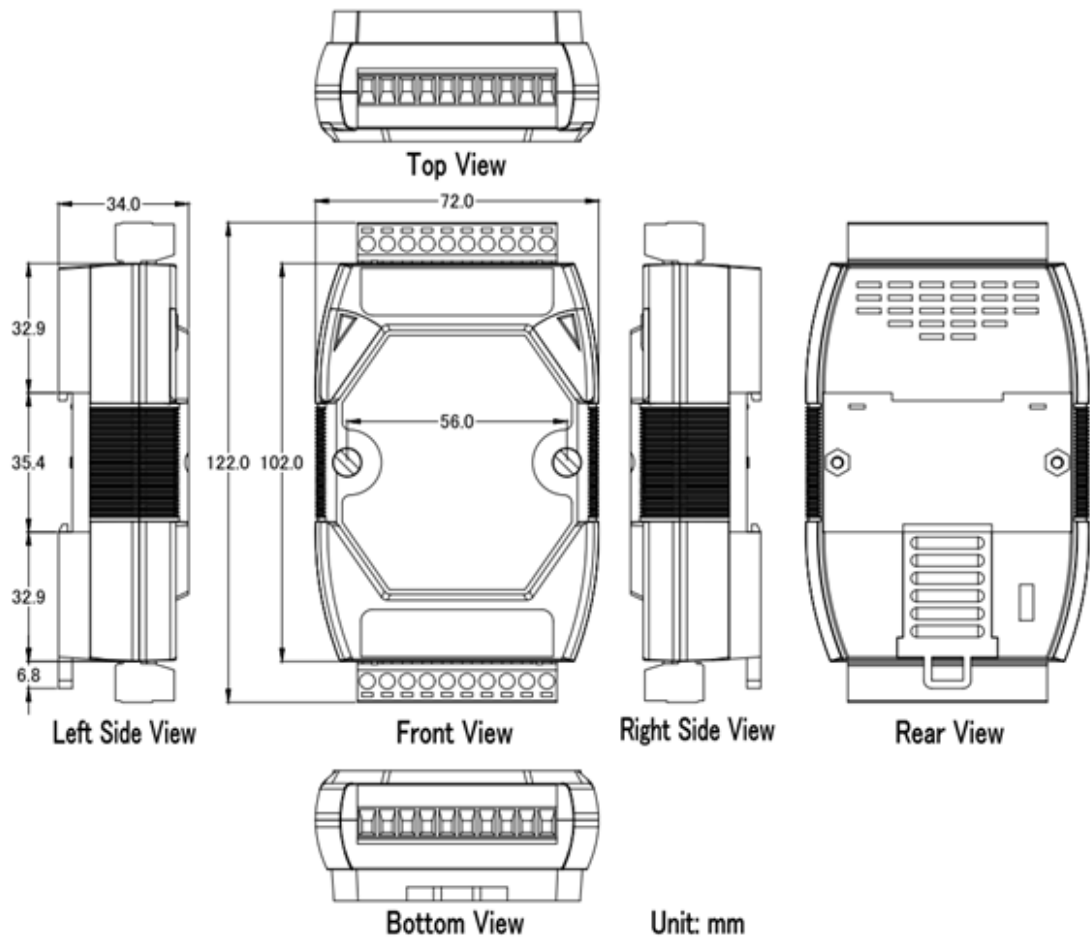

Figure10. Dimension