

# **GW-7433D MODBUS TCP Server & RTU Slave to CANopen Master**

## **User's Manual**

### **Warranty**

All products manufactured by ICP DAS are under warranty regarding defective materials for a period of one year from the date of delivery to the original purchaser.

### **Warning**

ICP DAS assumes no liability for damages resulting from the use of this product. ICP DAS reserves the right to change this manual at any time without notice. The information furnished by ICP DAS is believed to be accurate and reliable. However, no responsibility is assumed by ICP DAS for its use, or for any infringements of patents or other rights of third parties resulting from its use.

### **Copyright**

Copyright 2007 ~ 2008 by ICP DAS. All rights are reserved.

### **Trademark**

The names used for identification only may be registered trademarks of their respective companies.

## Table of Contents

1	General Information .....	3
1.1	CANopen Introduction .....	3
1.2	CANopen Applications.....	5
1.3	Module Characteristics .....	6
1.4	Hardware Features.....	7
1.5	Firmware Features .....	7
1.6	Specifications .....	8
1.7	Typical Applications .....	9
1.8	Modbus TCP/RTU to CANopen gateway.....	10
2	Hardware .....	12
2.1	Pin Assignment.....	12
2.1.1	RS-232 & RS-485 & Power supply interface .....	13
2.1.2	Connect to CANopen devices .....	14
2.1.3	Ethernet connection .....	15
2.1.4	Terminator resistor settings .....	16
2.2	LED Indication .....	18
2.2.1	Power LED .....	18
2.2.2	Module Status indicator LED.....	18
	<b>MI LED</b> .....	18
	<b>CI LED</b> .....	18
	<b>ERR LED &amp; ERROR Message show in 7-LED</b> .....	18
2.2.3	5-digits 7-Segment LED Displays.....	19
3	CANopen Interface .....	22
3.1	Network Communication .....	22
3.2	Slave Device Communication.....	22
3.3	Listen Mode.....	22
3.4	Interaction with Internal Memory .....	23
3.5	CAN Status Message .....	24
4	Modbus TCP/RTU Interface.....	25
4.1	Commands .....	25
4.2	Modbus TCP/RTU Addressing.....	26
4.2.1	I/O Data Addressing .....	26
4.2.2	Special Data Addressing .....	26
5	Appendix A – Software.....	29
5.1	GW-7433D Utility.....	29
5.2	Modbus Utility.....	30

# 1 General Information

## 1.1 CANopen Introduction

The CAN (Controller Area Network) is a serial communication protocol, which efficiently supports distributed real-time control with a very high level of security. It is an especially suited for networking “intelligent” devices as well as sensors and actuators within a system or sub-system. In CAN networks, there is no addressing of subscribers or stations in the conventional sense, but instead, prioritized messages are transmitted. CANopen is one kind of the network protocols based on the CAN bus and mainly used for machine control network, such as textile machinery, printing machines, injection molding machinery, or packaging machines, etc. CANopen is a low level network that provides connections between simple industrial devices (sensors, actuators) and higher-level devices (controllers), as shown in Figure 1.1.

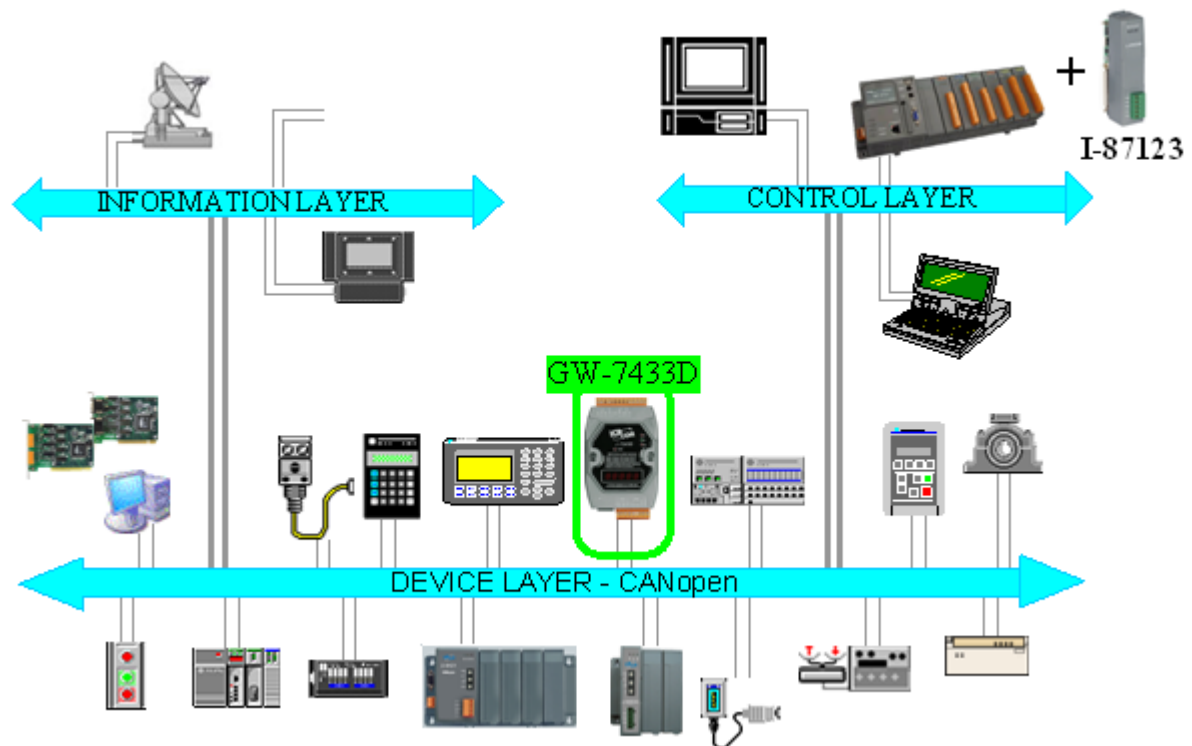

Figure 1.1 Example of the CANopen network

CANopen was developed as a standardized embedded network with highly flexible configuration capabilities. It provides standardized communication objects for real-time data (Process Data Objects, PDO),

configuration data (Service Data Objects, SDO), network management data (NMT message, and Error Control), and special functions (Time Stamp, Sync message, and Emergency message). Nowadays, CANopen is used in many various application fields, such as medical equipment, off-road vehicles, maritime electronics, public transportation, building automation and so on.

<b>Baud rate (bit/s)</b>	<b>Max. Bus length (m)</b>
10 K	5000m
20 K	2500 m
50 K	1000 m
125 K	500 m
250 K	250 m
500 K	100 m
800 K	50 m
1 M	25 m

**Table 1.1 The Baud rate and the Bus length**

## 1.2 CANopen Applications

CANopen is the standardized network application layer optimized for embedded networks. Its specifications cover the standardized application layer, frameworks for the various applications (e.g. general I/O, motion control system, maritime electronics and so forth) as well as device, interface, and application profiles.

The main CANopen protocol and products are generally applied in the low-volume and mid-volume embedded systems. The following examples show some parts of the CANopen application fields. (For more information, please refer to the web site, <http://www.can-cia.org>):

- Truck-based superstructure control systems
- Off-highway and off-road vehicles
- Passenger and cargo trains
- Maritime electronics
- Factory automation
- Industrial machine control
- Lifts and escalators
- Building automation
- Medical equipment and devices
- Non-industrial control
- Non-industrial equipment



### 1.3 Module Characteristics

“Embedded Internet” and “Embedded Ethernet” are hot topics today. Nowadays the Ethernet protocol becomes the de facto standard for local area network. Via Internet, connectivity is occurring everywhere, from home appliances to vending machines to testing equipment to UPS...etc. Using Ethernet for network in industrial area is appealing because the required cabling is already installed.

The GW-7433D from ICP DAS is a solution that provides a communication protocol to transfer the Modbus TCP/RTU to CANopen protocol and solves a mission-critical problem, connecting an existing CANopen network to Ethernet-based PLCs and PC-based configuration and monitor system. It enables CANopen networks to be coupled together over the Internet/Ethernet, whereby remote monitoring and control is possible.

The GW-7433D can be a CANopen master device in the CAN bus on the CANopen network. On the Ethernet network, it acts as a Modbus TCP server or Modbus RTU slave. Users can use Modbus TCP/RTU class 0, class 1 and partial class 2 functions to communicate with it. In addition, we also provide Utility software for users to configure their device parameters for the GW-7433D. The following figure shows the application architecture for the GW-7433D.

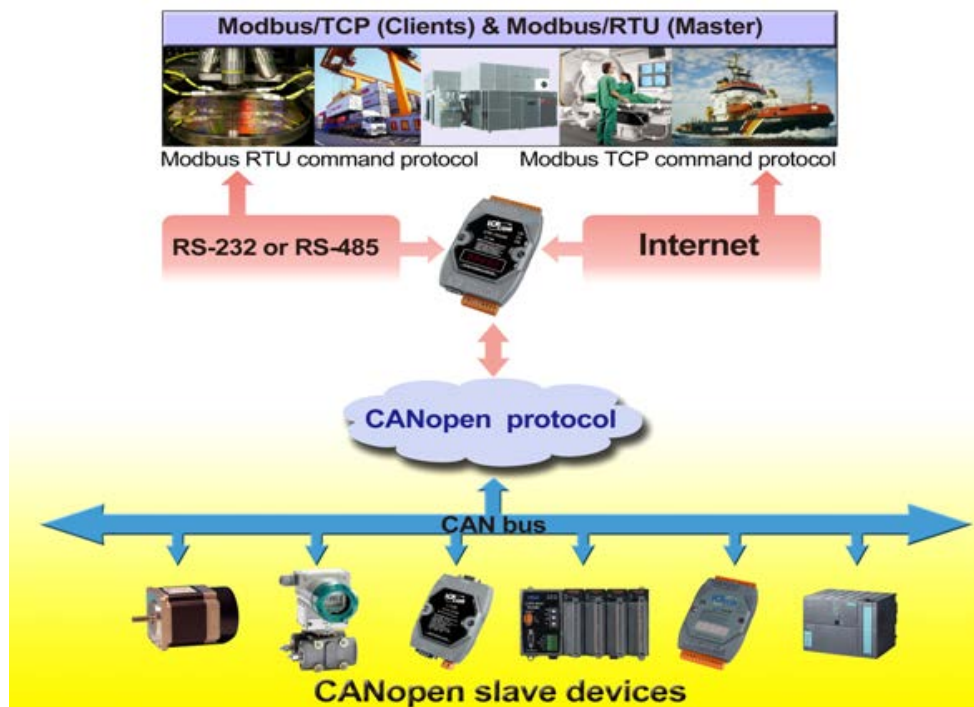

Figure 1.2 System application

## 1.4 Hardware Features

- 80186, 80MHz CPU, or compatible
- NXP SJA1000 CAN controller with 16 MHz clock
- NXP 82C250 CAN Transceiver
- 1K VDC isolation on CAN side.
- Support CAN specification 2.0A.
- Jumper select 120Ω terminator resistor for CAN channel
- 10/100 BASE-T DM9000AE compatible Ethernet Controller
- Support one RS-232 port, one RS-485 port and one CAN port
- Built-in self-tuner ASIC controller on RS-485 port
- 7-segment LED display.
- MI LED , CI LED , ERR LED

## 1.5 Firmware Features

- Allow to export/import the configuration of the GW-7433D to/from an xml file.
- Programmable CANopen transfer rate 10 k, 20 k, 50 k, 125 k, 250 k, 500 k, 800 k, 1 Mbps.
- Support up to 10 CANopen slave devices.
- Support maximum I/O: 6144 DI channels, 6144 DO channels, 1280 AI channels, and 1280 AO channels.
- Support message numbers: TxPDO+RxPDO+TxSDO+RxSDO are more than 250.
- Allow on-line adding device into CANopen network.
- Support boot-up auto communicate with slave devices.
- Provide CAN off-line detection.
- Support Node Guarding protocol and Heartbeat Consumer protocol.
- Provide Boolean, byte, word, and double word data types.
- Mapping the CANopen object to the Modbus address to by utility tool.
- Support Modbus TCP server or Modbus RTU slave functions at the same time.
- Allowed multi-Modbus TCP client access simultaneously.

## 1.6 Specifications

- RS-232 specification (**COM1**):
  - Communication speed: 115200 bps Max.
  - RS-232: TXD, RXD, RTS, CTS, GND.
  - Non-isolation.
  - Firmware upgrades port.
- RS-485 specification (**COM2**):
  - Communication speed: 115200 bps Max.
  - D2+, D2-.
  - Non-isolation.
  - Self-tuner ASIC inside.
- Ethernet specification:
  - 10/100 Base-T.
- CAN specification:
  - CAN signal support: CAN\_H, CAN\_L.
  - CAN bus interface: ISO 11898-2, screw terminal connector.
  - Isolation voltage: 1K V<sub>DC</sub> isolation on the CAN side.
- Power requirement:
  - Unregulated +10V<sub>DC</sub> ~ +30V<sub>DC</sub>.
  - Power reverse protection, Over-Voltage brown-out protection.
  - Power consumption: 3W.
- Module specification:
  - Dimensions: 123mm x 64.5mm x 19.6mm.
  - Operating temperature: -25 to 75°C.
  - Storage temperature: -30 to 80°C.
  - Humidity: 10 to 90%, non-condensing.
  - LEDs: Power, MI, CI, Err, and 5-digits 7 segment LED displays.
- Software Utility tool:
  - Online adding/removing CANopen devices via Ethernet.
  - Get/Set Modbus TCP/RTU input/output memory address.
  - Provide CANopen I/O mapping table.
  - Support TxPDO/RxPDO/TxSDO/RxSDO setting.
- Application:
  - Factory Automation.
  - Building Automation.
  - Control system.
  - Monitor system.
  - Vehicle Automation.



## 1.7 Typical Applications

The GW-7433D is designed as a Modbus TCP server or Modbus RTU Slave to CANopen master Gateway. It allows you to access the CANopen slave device by using Modbus commands. A GW-7433D is able to link up to 10 CANopen slave devices. Before using the GW-7433D, it is needed to use the GW-7433D Utility to set the GW-7433D IP address and COM port. Typical application architecture is shown below.

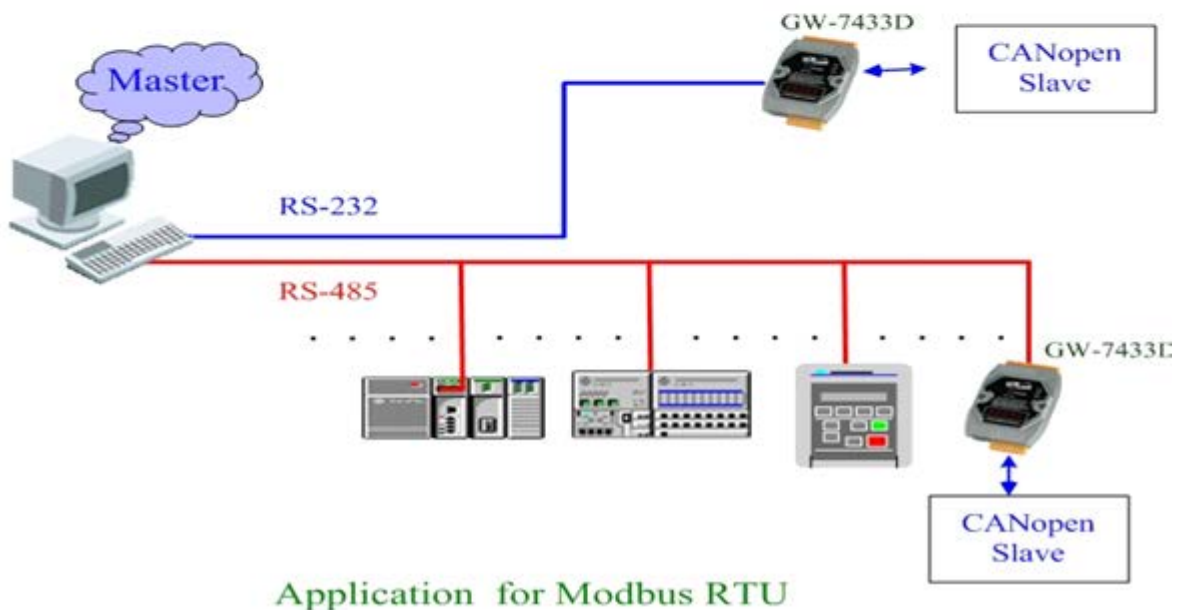
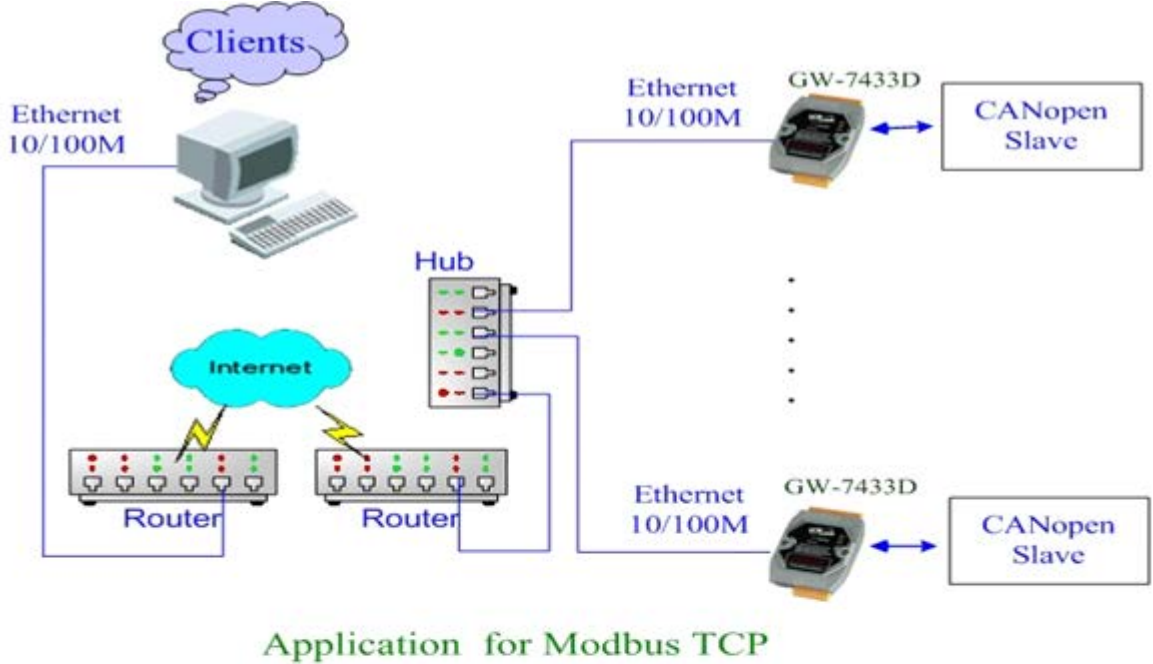

Figure 1.3: Application of GW-7433D

## 1.8 Modbus TCP/RTU to CANopen gateway

The GW-7433D provides centralized data storage, “Internal Memory”. This storage is shared by the CANopen and Modbus TCP/RTU network. Data come from one communication interface will be placed into the “Internal Memory”, then another communication interface can get the data from the memory area. The concept of the internal memory is shown below.

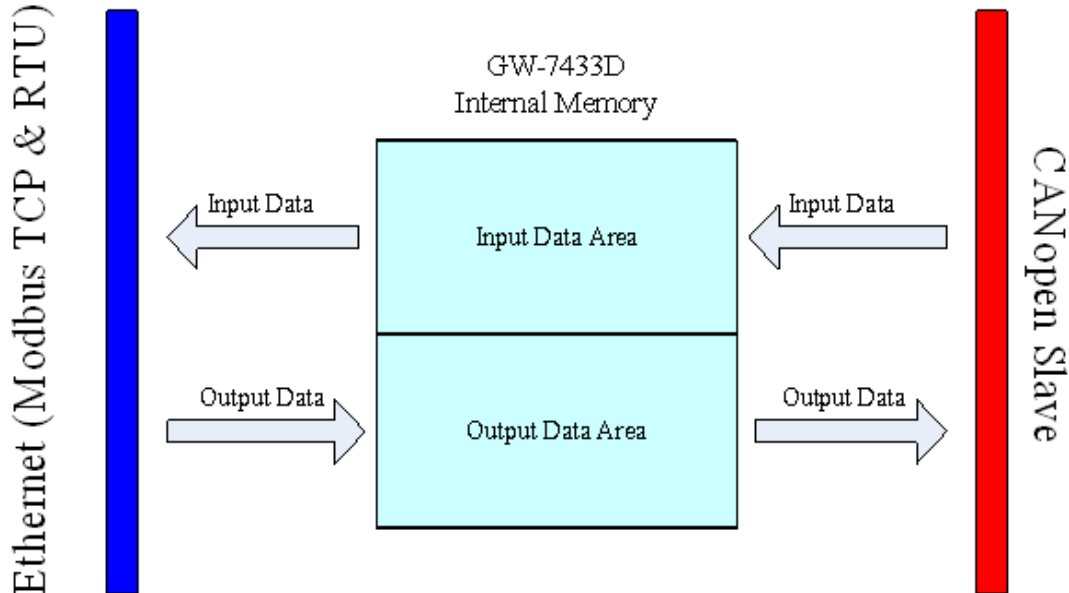

Figure 1.4: Internal Memory Table of GW-7433D

The GW-7433D acts as a Modbus TCP server or Modbus RTU slave to CANopen master gateway. Using the module, users don't need to take care of the detail of the CANopen protocol. The module will implement the CANopen protocol automatically. Therefore, it can efficiently reduce the complexity of building a CANopen network. When users would like to use SCADA software to control and monitor the CANopen network, the GW-7433D provides a solution for this requirement. The GW-7433D provides two kinds of protocols. One is the PDO protocol and another is SDO protocol. Basically, the PDO protocol is used for real I/O data. It is more efficient than the SDO because the PDO protocol don't have any protocol header. The SDO protocol is always used for configuration. In some devices, the device manufacturers provide the SDO method to get the device status. Therefore, before using the GW-7433D, users need to read the user manual of the CANopen slave device, and confirm the transmission protocols of the slave data which interest users. The communication concept between the GW-7433D and CANopen slaves are shown in the figure 1.6.

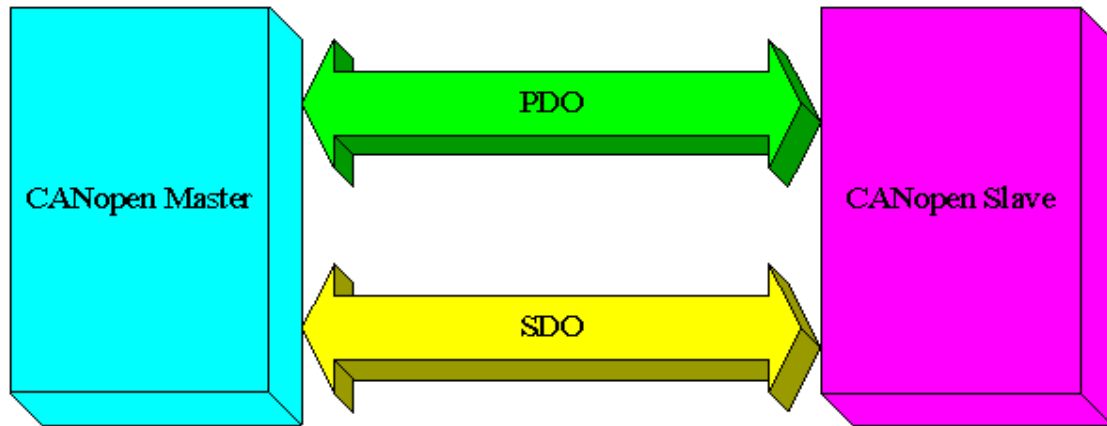

Figure1.6 CANopen Messaging

Before using the GW-7433D, users need to configure it by using GW-7433D Utility tool. The figure 1.7 demonstrates how to let the GW-7433D work and how to apply it in users' CANopen network.

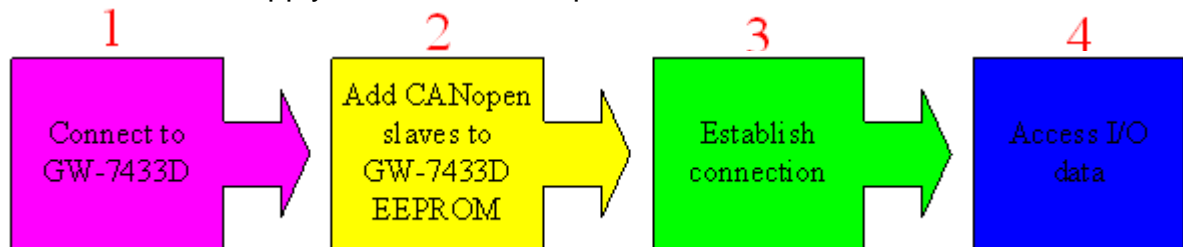

Figure 1.7 Four steps to establish connection

1. Connect to GW-7433D:

You have to use the GW-7433D Utility to connect to the GW-7433D first. In this step, the IP and mask of the GW-7433D must be used.

2. Add CANopen slave devices to GW-7433D EEPROM:

You can use the GW-7433D Utility to set the I/O configuration and communication parameters of the CANopen slave device, and save them into the GW-7433D. In this step, users need to read the CANopen slave user manual first, then decide what Cob-IDs are used and what CANopen protocols are implemented.

3. Establish connection:

After finishing the configuration and close the Utility, the GW-7433D will reboot and apply the new configuration automatically. Then, it starts to communication with the CANopen slave devices.

4. Access I/O data:

After communicating with slave devices, users can access the I/O data with corresponding Modbus address via the Ethernet port or COM port.

## 2 Hardware

### 2.1 Pin Assignment



Figure 2.1 Pin assignments on the GW-7433D

### 2.1.1 RS-232 & RS-485 & Power supply interface

The GW-7433D provides one RS-232 interface and one RS-485 interface. The GND-signal of COM1 is shared with pin-9, GND. The pin assignment is shown in table 2-1.



Figure 2.2 Pin assignments (power side)

Pin	Name	Description
1	CTS1	CTS of COM1 (RS-232)
2	RTS1	RTS of COM1 (RS-232)
3	RXD1	RXD of COM1 (RS-232)
4	TXD1	TXD of COM1 (RS-232)
5	INIT*	Pin for enable/disable auto execution firmware
6	D2+	Data+ of COM2 (RS-485)
7	D2-	Data- of COM2 (RS-485)
8	Vs+	V+ of power supply (+10V to +30V <sub>DC</sub> unregulated)
9	GND	Ground of power supply

Table 2-1: COM Connector Pin Assignment

### 2.1.2 Connect to CANopen devices

In order to provide an easy CAN bus wiring, the GW-7433D supplies one CAN port with two CAN bus connector interfaces. Each connector built on the GW-7433D looks like as figure 2.3 and table 2-2.



Pin No.	Signal	Description
1	N/A	Unavailable
2	CAN_L	CAN_L bus line (dominant low)
3	N/A	Unavailable
4	CAN_H	CAN_H bus line (dominant high)
5	N/A	Unavailable

Table 2-2 CAN bus Connector Pin Assignment

Note that the bypass CAN bus connector is not another CAN channel. It is designed for connecting to another CAN device conveniently. The structure of the inside electronic circuit is displayed as figure 2.4.

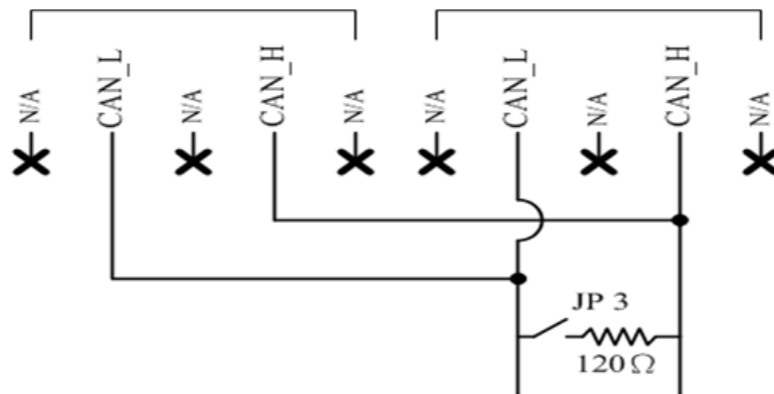
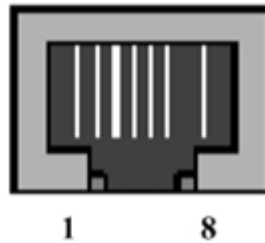

Figure 2.4 Electronic circuit of CAN bus connector

### 2.1.3 Ethernet connection

The Ethernet (10/100 Base-T) signals are routed to an RJ45 socket for easy connection using a standard CAT 3 or CAT 5 network cable. On power on of the GW-7433D, it will auto-negotiate the network speed and connection.



Pin	Name	Description
1	TX+	Transmit Data +
2	TX-	Transmit Data -
3	RX+	Receive Data +
4	N.C.	Not Connected
5	N.C.	Not Connected
6	RX-	Receive Data -
7	N.C.	Not Connected
8	N.C.	Not Connected

Table 2-3: Ethernet Connector Pin Assignment

### 2.1.4 Terminator resistor settings

In order to minimize reflection effects on the CAN bus line, the CAN bus lines have to be terminated at both ends by two terminal resistances. Based on the ISO 11898-2 spec, each terminal resistance is 120Ω (or between 108Ω~132Ω). The length related resistance should have 70 mΩ/m. Users should check the resistances of their CAN bus, before they install a new CAN network as figure 2.5.

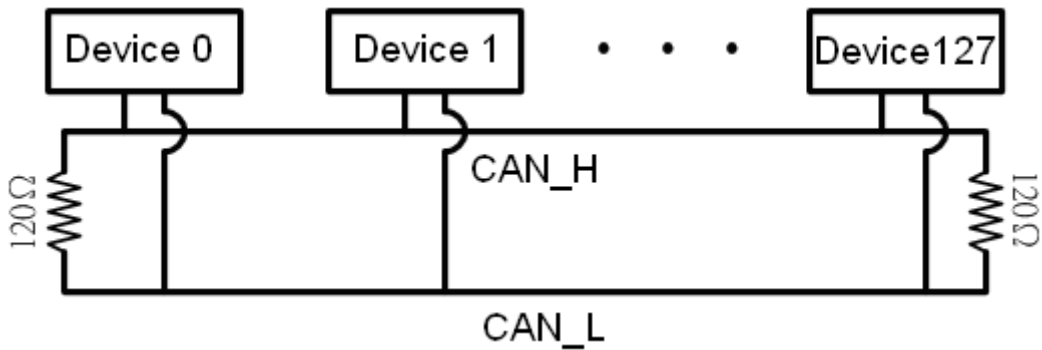

Figure 2.5 Terminator resistor

Moreover, to minimize the voltage drop on long distance, the terminal resistance should be higher than the value defined in the ISO 11898-2. Table 2-4 may be used as a reference.

Bus Length (meter)	Length Related Resistance (mΩ/m)	Cross Section (Type)	Terminal Resistance (Ω)
0~40	70	0.25(23AWG)~ 0.34mm <sup>2</sup> (22AWG)	124 (0.1%)
40~300	< 60	0.34(22AWG)~ 0.6mm <sup>2</sup> (20AWG)	127 (0.1%)
300~600	< 40	0.5~0.6mm <sup>2</sup> (20AWG)	150~300
600~1K	< 20	0.75~0.8mm <sup>2</sup> (18AWG)	150~300

Table 2-4: Relation between bus cable and length

Therefore, the GW-7433D module supplies a jumper for users to connect the terminator resistor or not. If users want to use this terminator resistor, please open the GW-7433D cover and use the JP3 jumper to activate the 120Ω terminator resistor built in the system, as in the figure 2.6. Note that the default setting is active. And about the J3 jumper setting, please refer the table 2-5.

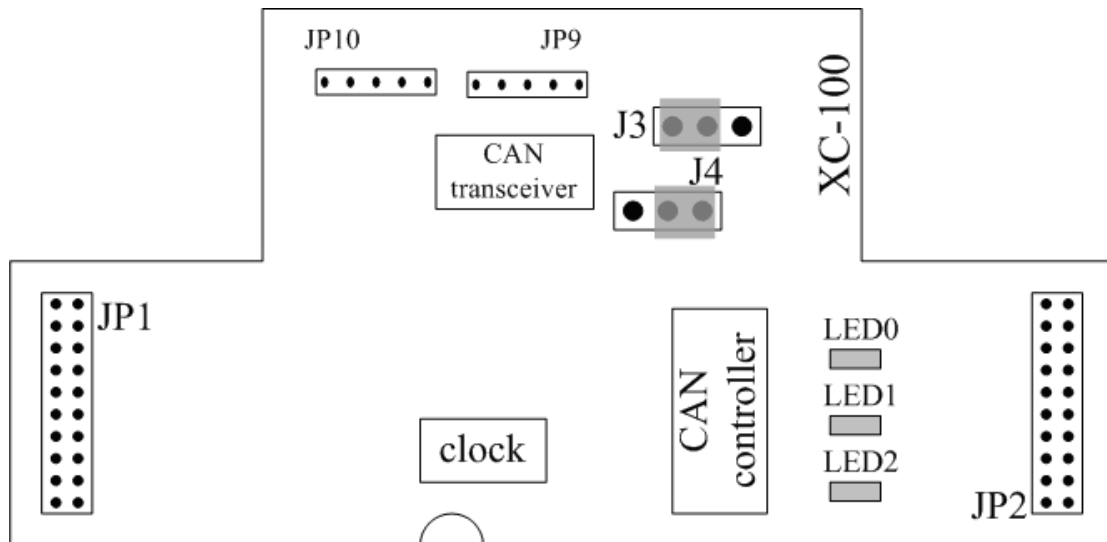

Figure 2.6 XC100 I/O expansion board LAYOUT

Apply the termination resistor(120Ω)	Don't apply the termination resistor
J3 	J3 

Table 2-5 J3 Jumper Selection

## 2.2 LED Indication

The GW-7433D provides three LEDs to indicate what situation is in the GW-7433D. They are described as follows.

### 2.2.1 Power LED

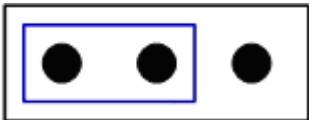
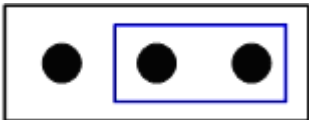
The GW-7433D needs +10 ~ +30 V<sub>DC</sub> power input and consumes 3W. The Power LED will be turn on after applying power and it will be flashing one time per second.

### 2.2.2 Module Status indicator LED

The GW-7433D includes three single-color LED displays to indicate the status of module, network and I/O device. They are MI LED (it is red), CI LED (it is green), and ERR LED (it is red). The indicators assist maintenance personnel in quickly identifying a problem unit. When the GW-7433D events occur, these indicators will be triggered to glitter with different conditions.

#### **MI LED**

The LED indicates the Modbus communication status of the GW-7433D. Following shows the condition of MI status. When GW-7433D is working and has received a Modbus message, the MI LED will be flash red.

- LED off: The GW-7433D receives no Modbus command.
- LED on: The GW-7433D is receiving a Modbus command.

#### **CI LED**

This LED indicates the CANopen communication status of the module. Following shows the conditions of CI status. When module is online and start to communicate with the devices, it will flash. If there are no TxPDO, RxPDO, TxSDO, RxSDO protocol running, then the CI LED will be turn off.

- LED off: The GW-7433D receives no CANopen message.
- LED on: The GW-7433D is receiving a CANopen message.

#### **ERR LED & ERROR Message show in 7-LED**

This LED indicates the CANopen status of the GW-7433D. The following description shows the conditions of error status.

- LED off: The GW-7433D has no error.
- LED flash: The GW-7433D gets some communication errors.
- LED on: GW-7433D gets some configuration errors.

**Note: The table 2-6, section 3.4, and 4.2.2 have more information about the details of error messages.**

### 2.2.3 5-digits 7-segment LED Displays

While the GW-7433D boots up, the 5-digits 7-segment LED of the GW-7433D shows the communication configurations and error status. All of the information is divided into 4 groups. These groups are displayed by turns. The information is shown as the figure 2.7.

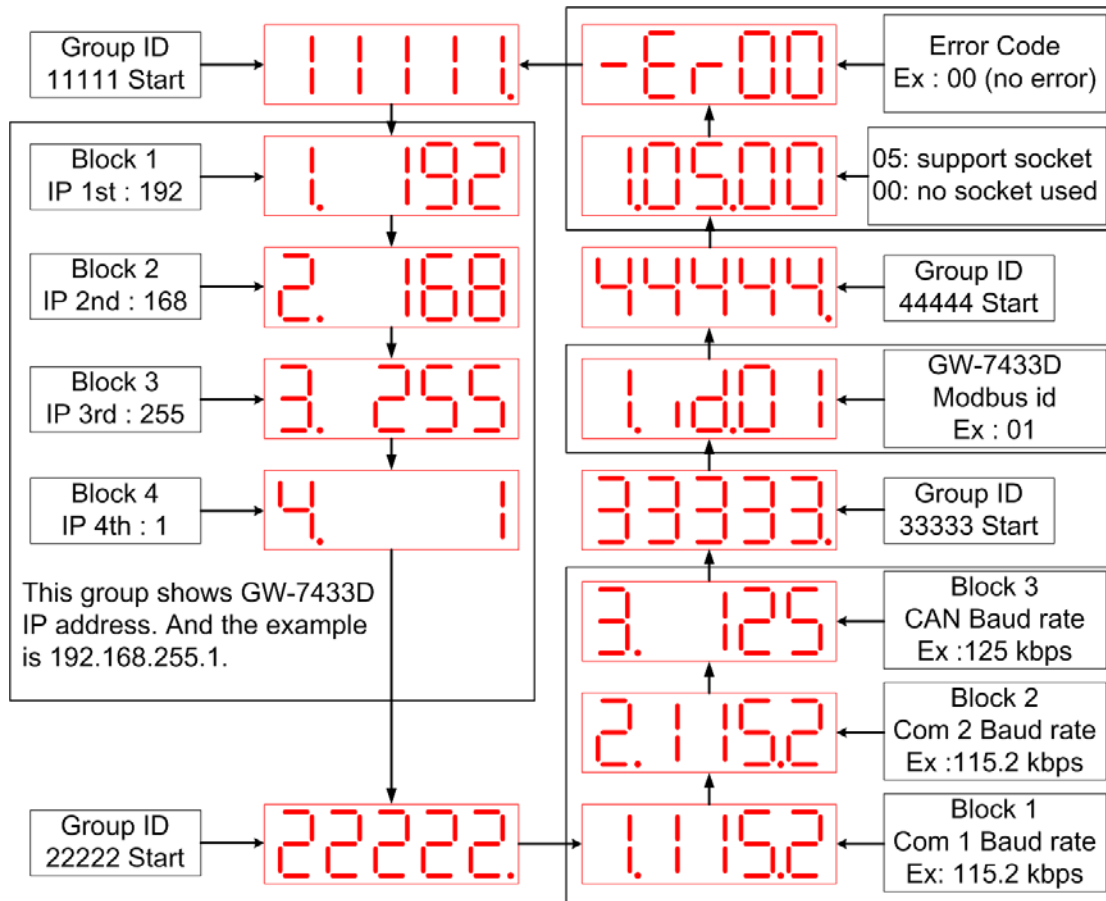

Figure 2.7 The meaning of the 7-segment LED

The information groups of the GW-7433D are as the following list.

- Group-ID 11111: IP information of this GW-7433D
- Group-ID 22222: baud rate of all ports
- Group-ID 33333: configuration of GW-7433D station number.
- Group-ID 44444: client connection information and error state of this GW-7433D

The IP information format of the GW-7433D is given as follows:

- Group-ID of 5-digit LED: 11111.
- LED-1: indicator, can be 1 or 2 or 3 or 4 for 4 sections of IP address
- LED-2~5: IP address

The LED shows Group-ID first, and then shows its IP address as the figure 2.7. If users change the IP address, the value shown on the LED will be changed immediately. The default IP address is 192.168.255.1 and the default Mask is 255.255.0.0.

The baud rate of the COM1, COM2 and CAN port are given as follows:

- Group-ID of 5-digit LED: 22222.
- LED-1: port number. 1 for COM1, 2 for COM2, 3 for CAN port.
- LED-2~5: baud rate. This value needs to multiply by 1000. For COM1 and COM2, the range is from 1.2~115.2 (means 1.2 kbps ~ 115.2 kbps). For CAN port, the range is from 10~1000 (means 10 kbps ~ 1000 kbps)

The configuration of the communication is given as follows:

- Group-ID of 5-digit LED: 33333.
- LED-1: indicators, always 1.
- LED-2, 3: fix string, "id."
- LED-4, 5: The Modbus station ID of the GW-7433D.

The connection-client information is given as follows:

- Group-ID of 5-digit LED: 44444.
- LED-1: indicators, always 1.
- LED-2, 3: total supported socket numbers (5 sockets).
- LED-4, 5: numbers of sockets are used by clients, default 0.

If any client connects to the GW-7433D, the numbers of the used-socket will be increased. The GW-7433D allows 5 clients for connection. So if the used-socket number is 5, no more clients can link to the GW-7433D.

The error status of the GW-7433D is given as follows:

- LED-1~3: fix string, "-Er".
- LED-4, 5: error code, normal is 00. **The details of the error codes are shown below (table 2-6).**

**Users also can get the error status by the Modbus commands. For the details please refer to the section 3.4 and 4.2.2.**

<b>Error code (LED)</b>	<b>Description</b>
-Er00	No error
-Er45 *	Guarding or Heartbeat event occurred
-Er46 *	Guarding or Heartbeat setting error
-Er47 *	A CANopen slave had disconnected
-Er48 *	Transmit / receive CAN data error
-Er49 *	CAN Bus off
-Er50 *	EEPROM initialization error
-Er51	CANopen slave amount over the range (1 ~ 10)
-Er52	CANopen slave node ID is over the range (1 ~ 127)
-Er53	There is a PDO COB_ID over the range (0 ~ 0x7FF)
-Er54 *	Install com port error
-Er55 **	PDO Count >100
-Er56 **	SDO Count >15
-Er57 *	Total DO channels are over 3072 (384 bytes)
-Er58 *	Total DI channels are over 3072 (384 bytes)
-Er59 *	Total AO channels are over 640
-Er60 *	Total AI channels are over 640

Table 2-6 Error code table

\* : Only for the GW-7433D firmware v2.00 or later.

\*\* : Only for the GW-7433D firmware v1.xx.

## **3 CANopen Interface**

### **3.1 Network Communication**

The GW-7433D, Modbus TCP/RTU to CANopen Gateway, acts as a CANopen master on CANopen network. It can exchange I/O data with up to 10 modules. Users can use the GW-7433D Utility tool to mapping CANopen slave's data into the GW-7433D via Ethernet, and then the GW-7433D will work.

### **3.2 Slave Device Communication**

After the configuration of CANopen slave devices, please run the CANopen slave device in the pre-operation mode. Use the GW-7433D utility to configure the mapping table of the CANopen slave's data. When you finish the GW-7433D utility configuration and close the utility, the GW-7433D will auto re-boot the firmware, and poll the TxPDO and TxSDO data of the CANopen slave devices as soon as possible. The RxPDO and RxSDO communication are decided by the mode. If the cyclic mode is used, the GW-7433D sends the RxPDO cyclically even the DO or AO data are the same as previous ones. If users use normal mode, the RxPDO is only sent while the GW-7433D gets the Modbus command to send the DO or AO data.

### **3.3 Listen Mode**

If users want the GW-7433D to monitor the CANopen network but not to send any message to the CANopen network, this function will be useful. For example, if users have two GW-7433Ds in his application, the one is in normal mode and another is in listening mode, the input data (DI / AI) of the one in the listen mode will be the same as the one in normal mode. Therefore, users can use this function to be the second monitor of the CANopen network.

### 3.4 Interaction with Internal Memory

When the GW-7433D works, it monitors the CANopen network and updates the AI or DI data in the corresponding internal memory if these data responds from the CANopen slaves automatically. The GW-7433D also uses RTR message to get the DI and AI data, and put these data into the corresponding internal memory. When the Modbus TCP client or Modbus RTU master commands to the GW-7433D for getting AI or DI data, the GW-7433D reply the AI and DI data from the internal memory. When the Modbus TCP client or Modbus RTU master wants to output the data to the DO or AO channels of the CANopen slaves, it send Modbus commands to the GW-7433D. Then, GW-7433D keeps theses data in the corresponding internal memory and sends the CANopen messages immediately or cyclically (due to the RxPDO mode) for outputting the DO and AO data. When users use the cyclic mode of the RXPDO, the GW-7433D will update the DO or AO data by using the data in the corresponding internal memory cyclically.

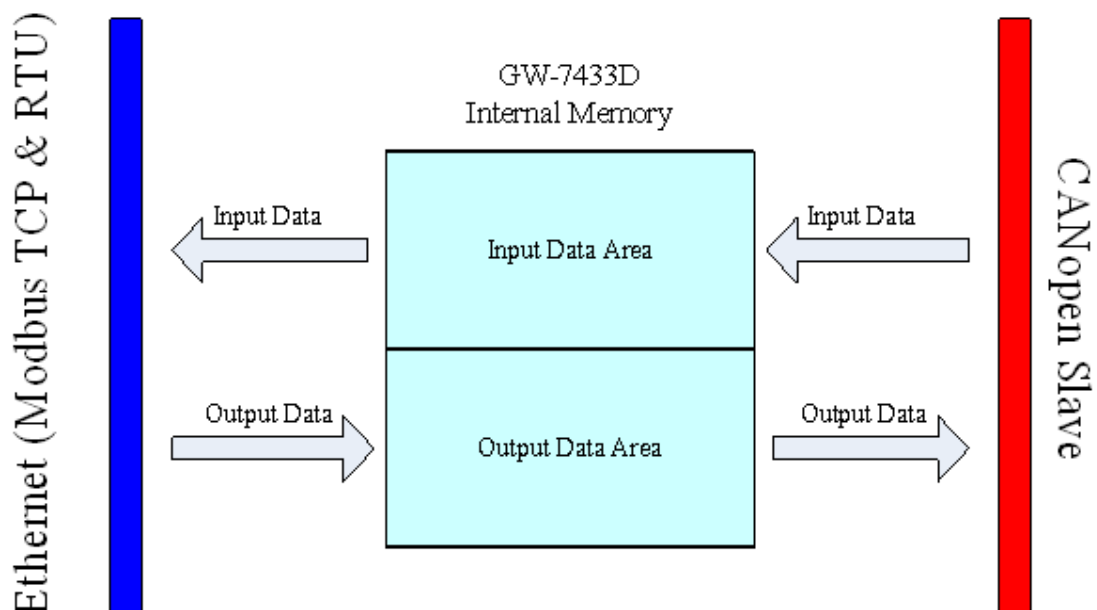

Figure 3.1 Internal Memory Table of GW-7433D

### 3.5 SJA1000 CAN Status

Users can use the Modbus command to get the CAN status of the SJA1000 CAN controller which is applied in GW-7433D. The meaning of each bit of the CAN status is as follow table 3-1. About how to get the CAN status please refer to the **section 4.2.2 (Special Data Addressing)**.

Bit	Name	Value	Function
Bit. 7	Bus Status	1	<b>bus-off</b> ; the SJA1000 is not allowed to access the CANopen network
		0	<b>bus-on</b> ; the SJA1000 is ready to access the CANopen network.
Bit. 6	Error Status	1	<b>error</b> ; at least one of the error counters has reached or exceeded the CPU warning limit
		0	<b>ok</b> ; both error counters are under the warning limit
Bit. 5	Transmit Status	1	<b>transmit</b> ; the SJA1000 is transmitting a message
		0	<b>idle</b> ; no transmit message is in progress
Bit. 4	Receive Status	1	<b>receive</b> ; the SJA1000 is receiving a message
		0	<b>idle</b> ; no receive message is in progress
Bit. 3	Transmission Complete Status	1	<b>complete</b> ; the last requested transmission has been successfully completed
		0	<b>incomplete</b> ; the previously requested transmission is not yet completed
Bit. 2	Transmit Buffer Status	1	<b>released</b> ; the CPU may write a message into the transmit buffer
		0	<b>locked</b> ; the CPU cannot access the transmit buffer; a message is waiting for transmission or is already in process
Bit. 1	Data Overrun Status	1	<b>overrun</b> ; a message was lost because there was not enough space for that message in the RXFIFO
		0	<b>absent</b> ; no data overrun has occurred since the last clear data overrun command was given
Bit. 0	Receive Buffer Status	1	<b>full</b> ; one or more messages are available in the RXFIFO
		0	<b>empty</b> ; no message is available

Table 3-1 Bit interpretation of the CAN status

## 4 Modbus TCP/RTU Interface

The GW-7433D supports class 0, class 1 and partial class 2 Modbus slave functionalities. The Modbus TCP client or Modbus RTU master connected to the GW-7433D needs to follow the Modbus TCP/RTU specification 1.0.

The GW-7433D can handle maximum 5 Modbus TCP connections, and one RS-232(COM1) or RS-485(COM2) connection simultaneously.

### 4.1 Commands

The following Modbus TCP/RTU commands are supported by the GW-7433D.

Function	Function Name	Class	Affects	Data Type
1	Read Multiple Coils	1	DO	Bit
2	Read Multiple Input Discrete	1	DI	Bit
3	Read Multiple Registers	0	AO	Word
4	Read Multiple Input Registers	1	AI	Word
5	Write Single Coil	1	DO	Bit
6	Write Single Register	1	AO	Word
15	Force Multiple Coils	2	DO	Bit
16	Force Multiple Registers	0	AO	Word

Table 4-1: Modbus Commands

## 4.2 Modbus TCP/RTU Addressing

### 4.2.1 I/O Data Addressing

The GW-7433D provides a piece of the internal memory for saving I/O data. The table 4-2 shows the detail information of the memory type, data type, address, and so on. After using GW-7433D Utility to configure the mapping information of the CANopen slaves, users can get the mapping table between the Modbus address and CANopen data. The information of the Modbus memory assignment and corresponding data type are shown below.

Memory Type	Command Start Addr	PLC Start Addr	Max channel	Support CANopen Data Type	Support Function
DI	0000h	00001h	3072	Boolean	2
DO	0000h	10001h	3072	Boolean	1, 5, 15
AI	0000h	30001h	640	Byte, Word, 4-byte	4
AO	0000h	40001h	640	Byte, Word, 4-byte	3, 6, 16

Table 4-2: I/O Data Addressing

### 4.2.2 Special Data Addressing

The GW-7433D supports special data such as the error status of the CANopen slave, reset command, and so on. The table 4-3 shows the details of these special data addresses.

Type	Address	Description
AI	Max. AI address + n *1 *2	Read n <sup>th</sup> CANopen slave's error status. *4
AI	Max. AI address + N + 1 *3	Read the GW-7433D's error status. *4
AI	Max. AI address + N + 2 *3	Read the GW-7433D's CAN status. *5

AO	Max. AO address + n *1 *2	Send status command to n <sup>th</sup> CANopen slave. (write only) *6
AO	Max. AO address + N + 1 *3	Reset the GW-7433D. (write only) *7
AO	Max. AO address + N + 2 *3	Set the GW-7433D to "Listen Mode" *8

Table 4-3: Special Data Addressing

\*1: The Max. AI/AO address is decided by the maximum AI/AO channels configuration by utility. For example, if users finish the configuration by the GW-7433D utility, check the mapping table and find that there are 8 AI data (16-bytes) assigned in the Modbus memory, the Max. AI address is 0007h (or 30008h for PLC) because the useful AI channel is from 0 ~ 7.

\*2: "n" is the CANopen slave device number. The number range is 1 ~ 10.

\*3: "N" is the total CANopen slave device amount.

\*4: About the error status, please refer to the table 2-6.

\*5: About the CAN status, please refer to the table 3-1.

\*6: GW-7433D can send status command to CANopen slave through this address (Max. AO address + n). Write 0x01 to this address will let the relative CANopen slave into "Operational mode" status, write 0x02 to into "Stop mode" status, write 0x80 to into "Pre-operational mode" status and write 0x81 to reset this CANopen slave.

\*7: Writing the address (Max. AO address + N + 1) to 1 will let the GW-7433D reboot.

\*8: Writing the address (Max. AO address + N + 2) to 1 will let the GW-7433D into listen mode. If users want to recover to the normal mode, please write it to 0. About the details of "Listen Mode", please refer to **section 3.3**.

### Example 1: Get the CANopen slave device's error status.

Assume that the GW-7433D connects 2 CANopen slaves and with total **10 AI channels**, users can send the follow Modbus TCP command to **get these two CANopen slaves' status**.

Query --> 1 2 0 0 0 6 01 04 **00 0A 00 02**

Response --> 1 2 0 0 0 6 01 04 04 **00 00 00 2F** (for Big-endian data type\*)

The green word **00 0A** is the address for the CAN error status because the address 00 00 ~ 00 09 are for AI data. The orange word **00 02** indicates getting the error status of two slaves. The blue word is 1<sup>st</sup> CANopen slave's error status, and **00 00** means no error. The red data is 2<sup>nd</sup> CANopen slave's error status, and **00 2F** (47) means the slave has disconnected.

### Example 2: Reset the CANopen slave device.

Assume the GW-7433D connects 2 CANopen slaves and with total **8 AO channels**. When users want to **reset 2<sup>nd</sup> CANopen slave**, users can send the follow Modbus TCP command to the GW-7433D and it will send a CANopen reset command to the slave.

Query --> 1 2 0 0 0 6 01 06 **00 09 00 81** (for Big-endian data type\*)

Response --> 1 2 0 0 0 6 01 06 00 09 00 81 (for Big-endian data type\*)

The address **00 09** is the 2<sup>nd</sup> CANopen slave reset command address because the 00 08 is 1<sup>st</sup> CANopen slave reset command address and the 00 00 ~ 00 07 are the address for AO channel 0 ~ 7. The command **00 81** is to reset 2<sup>nd</sup> CANopen slave.

**\* GW-7433D Modbus data support two kinds of the word data type, Little-endian and Big-endian, and the Big-endian type is the default type. The different type will influence the data byte order. Users can select this type through GW-7433D Utility.**

## 5 Appendix A – Software

### 5.1 GW-7433D Utility

The GW-7433D utility is a setting tool for the GW-7433D configuration. The details about the GW-7433D utility please refer to the GW-7433D utility user manual. Users can get the all related files of GW-7433D such as GW-7433D Utility from the following positions.

<https://www.icpdas.com/en/download/index.php?model=GW-7433D-G>

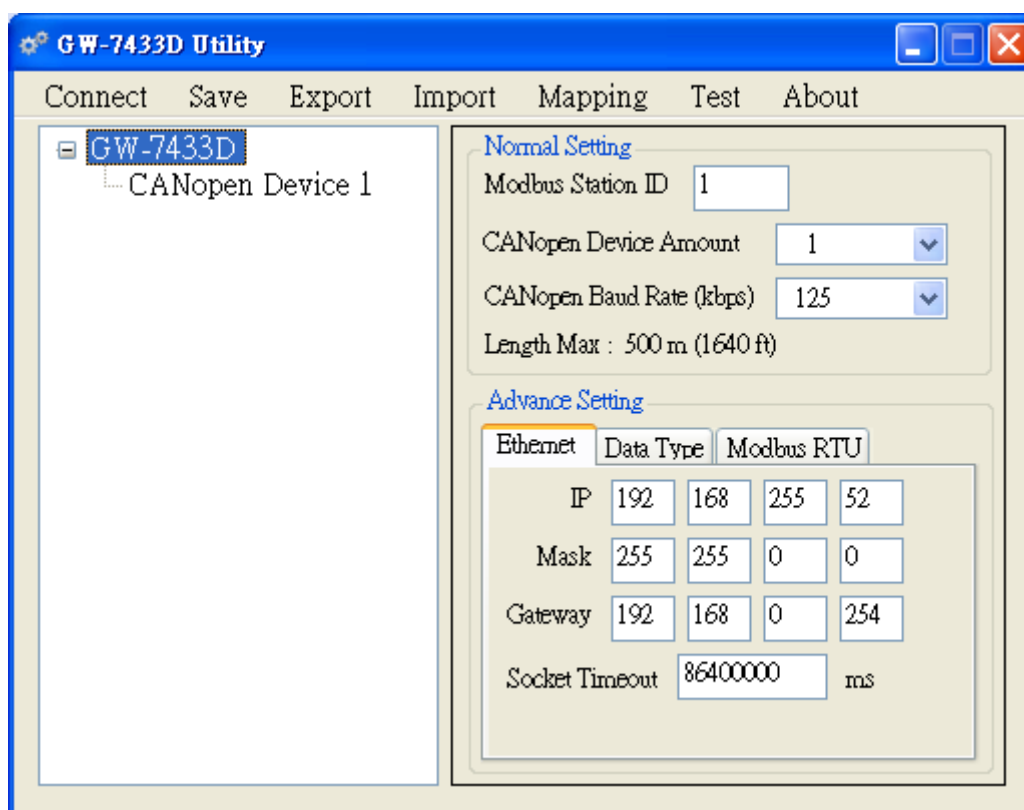

## 5.2 Modbus Utility

The Modbus utility includes the MBTCP and MBRTU tools. The MBTCP is a Modbus TCP client with source code in VB6. The MBRTU is a Modbus RTU master with source code in VB6. These two tools are designed by ICP DAS and they are helpful when users want to diagnostic the Modbus TCP server devices or Modbus RTU slaves. Users can free download the utility from the following web site:

[http://www.icpdas.com/products/PAC/i-8000/modbus\\_web\\_download.htm](http://www.icpdas.com/products/PAC/i-8000/modbus_web_download.htm)

