

tGW-700 Series GW-2200 Series User Manual



Tiny Modbus/TCP to RTU/ASCII Gateway Ver. 2.8, Sep. 2025

WARRANTY

All products manufactured by ICP DAS are warranted against defective materials for a period of one year from the date of delivery to the original purchaser.

WARNING

ICP DAS assumes no liability for damages consequent to the use of this product. ICP DAS reserves the right to change this manual at any time without notice. The information furnished by ICP DAS is believed to be accurate and reliable. However, no responsibility is assumed by ICP DAS for its use, nor for any infringements of patents or other rights of third parties resulting from its use.

COPYRIGHT

Copyright © 2025 by ICP DAS. All rights are reserved.

TRADEMARKS

Names are used for identification purposes only and may be registered trademarks of their respective companies.

CONTACT US

If you have any questions, please feel free to contact us via email at:

service@icpdas.com

SUPPORT

This manual relates to the following modules:

tGW-712, tGW-722, tGW-732
tGW-715, tGW-725, tGW-735
tGW-718, tGW-724, tGW-734
tGW-712i, tGW-722i, tGW-732i
tGW-715i, tGW-725i, tGW-735i
tGW-718i, tGW-724i, tGW-734i
tGW-718i-D
tGW-715-T, tGW-715i-T,
tGW-718-T, tGW-718i-T,
GW-2212i, GW-2222i, GW-2232i
GW-2215i, GW-2225i, GW-2235i

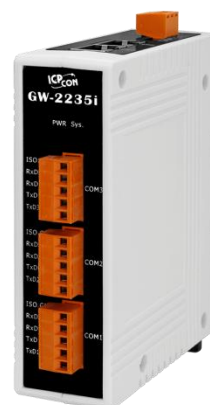

TABLE OF CONTENTS

PACKING LIST	- 6 -
MORE INFORMATION	- 7 -
1. INTRODUCTION	- 8 -
1.1 FEATURES	- 10 -
1.2 APPLICATIONS	- 10 -
1.3 ETHERNET SOLUTIONS	- 11 -
1.4 WEB SERVER TECHNOLOGY	- 12 -
2. HARDWARE INFORMATION	- 13 -
2.1 SPECIFICATIONS	- 13 -
2.2 APPEARANCE	- 14 -
<i>PoE and Ethernet RJ-45 Jack</i>	<i>- 15 -</i>
<i>+12 to +48 VDC Jack</i>	<i>- 15 -</i>
<i>Operating Mode Switch</i>	<i>- 16 -</i>
<i>LED Indicator</i>	<i>- 16 -</i>
<i>Serial COM Ports</i>	<i>- 17 -</i>
<i>DIN-Rail Mounting</i>	<i>- 17 -</i>
2.3 DIMENSIONS	- 18 -
<i>tGW-700 Series Module (Unit: mm)</i>	<i>- 18 -</i>
<i>CA-002 Cable (Unit: mm)</i>	<i>- 19 -</i>
<i>tGW-700-T Series Module (Unit: mm)</i>	<i>- 20 -</i>
<i>GW-2200 Series Module (Unit: mm)</i>	<i>- 21 -</i>
2.4 PIN ASSIGNMENTS	- 22 -
<i>tGW-712/tGW-712i</i>	<i>- 22 -</i>
<i>tGW-722/tGW-722i</i>	<i>- 22 -</i>
<i>tGW-732/tGW-732i</i>	<i>- 23 -</i>
<i>tGW-715/tGW-715i/tGW-715-T/tGW-715i-T</i>	<i>- 23 -</i>
<i>tGW-725/tGW-725i</i>	<i>- 24 -</i>
<i>tGW-735/tGW-735i</i>	<i>- 24 -</i>
<i>tGW-718/tGW-718i/tGW-718-T/tGW-718i-T</i>	<i>- 25 -</i>
<i>tGW-718i-D</i>	<i>- 25 -</i>
<i>tGW-724/tGW-724i</i>	<i>- 26 -</i>
<i>tGW-734/tGW-734i</i>	<i>- 26 -</i>
<i>GW-2212i/2222i/2232i</i>	<i>- 27 -</i>
<i>GW-2215i/2225i/2235i</i>	<i>- 28 -</i>

2.5	WIRING NOTES FOR RS-232/485/422 INTERFACES.....	- 29 -
	<i>RS-232 Wiring</i>	- 29 -
	<i>RS-422 Wiring</i>	- 30 -
	<i>RS-485 Wiring</i>	- 30 -
3.	GETTING STARTED FOR TGW-700 / GW-2200 SERIES ON IPV4	- 31 -
3.1	CONNECTING THE POWER AND HOST PC	- 31 -
3.2	CONFIGURING NETWORK SETTINGS.....	- 35 -
3.3	CONNECTING THE MODBUS DEVICES	- 37 -
3.4	CONFIGURING THE SERIAL PORT	- 38 -
3.5	SELF-TEST.....	- 41 -
4.	GETTING STARTED FOR TGW-700 / GW-2200 SERIES ON IPV6	- 42 -
4.1	CONNECTING THE POWER AND HOST PC	- 42 -
4.2	CONFIGURING NETWORK SETTINGS.....	- 46 -
4.3	CONNECTING THE MODBUS DEVICES	- 48 -
4.4	CONFIGURING THE SERIAL PORT	- 49 -
4.5	SELF-TEST.....	- 53 -
5.	WEB CONFIGURATION	- 55 -
5.1	LOGGING IN TO THE TGW-700/GW-2200 WEB SERVER.....	- 55 -
5.2	HOME PAGE	- 57 -
5.3	NETWORK PAGE	- 58 -
	5.3.1 <i>IP Address Selection</i>	- 58 -
	5.3.2 <i>General Settings</i>	- 62 -
	5.3.3 <i>Modbus Settings</i>	- 63 -
	5.3.4 <i>Other Operations</i>	- 65 -
5.4	SERIAL PORT PAGE	- 68 -
	5.4.1 <i>Settings (Port1 Settings)</i>	- 68 -
	5.4.2 <i>Settings (Pair-Connection Settings)</i>	- 72 -
5.5	FILTER PAGE	- 73 -
5.6	SNMP PAGE	- 74 -
	5.6.1 <i>SNMP Configuration Setting</i>	- 75 -
	5.6.2 <i>SNMP I/O Example</i>	- 77 -
	5.6.3 <i>SNMP Trap Example</i>	- 80 -
	5.6.4 <i>SNMP Troubleshooting</i>	- 82 -
5.7	MONITOR PAGE	- 84 -

5.8	PASSWORD PAGE.....	- 85 -
5.9	LOGOUT PAGE.....	- 86 -
6.	TYPICAL APPLICATIONS	- 87 -
6.1	MODBUS GATEWAY	- 88 -
6.2	MODBUS NET ID	- 89 -
6.3	PAIR-CONNECTION APPLICATIONS	- 90 -
6.4	TCP CLIENT MODE APPLICATIONS	- 98 -
7.	MODBUS INFORMATION	- 103 -
7.1	MODBUS MESSAGE STRUCTURE	- 103 -
	<i>01(0x01) Read the Status of the Coils (Readback DOs).....</i>	<i>- 106 -</i>
	<i>02(0x02) Read the Status of the Input (Read DIs).....</i>	<i>- 107 -</i>
	<i>03(0x03) Read the Holding Registers (Readback AOs)</i>	<i>- 108 -</i>
	<i>04(0x04) Read the Input Registers (Read AIs).....</i>	<i>- 109 -</i>
	<i>05(0x05) Force a Single Coil (Write DO)</i>	<i>- 110 -</i>
	<i>06(0x06) Preset a Single Register (Write AO).....</i>	<i>- 111 -</i>
	<i>15(0x0F) Force Multiple Coils (Write DOs).....</i>	<i>- 112 -</i>
	<i>16(0x10) Preset Multiple Registers (Write AOs)</i>	<i>- 113 -</i>
7.2	EXCEPTION CODES	- 114 -
	APPENDIX A: TROUBLESHOOTING	- 116 -
	A1. HOW DO I RESTORE THE WEB PASSWORD FOR THE MODULE TO THE FACTORY DEFAULT PASSWORD?	- 116 -
	APPENDIX B: GLOSSARY	- 118 -
1.	ARP (ADDRESS RESOLUTION PROTOCOL)	- 118 -
2.	CLIENTS AND SERVERS	- 118 -
3.	ETHERNET	- 119 -
4.	FIRMWARE	- 119 -
5.	GATEWAY.....	- 119 -
6.	ICMP (INTERNET CONTROL MESSAGE PROTOCOL)	- 119 -
7.	INTERNET.....	- 119 -
8.	IP (INTERNET PROTOCOL) ADDRESS	- 120 -
9.	MAC (MEDIA ACCESS CONTROL) ADDRESS.....	- 120 -
10.	PACKET.....	- 120 -
11.	PING.....	- 120 -
12.	RARP (REVERSE ADDRESS RESOLUTION PROTOCOL)	- 120 -
13.	SOCKET	- 121 -

14. **SUBNET MASK**..... - 121 -

15. **TCP (TRANSMISSION CONTROL PROTOCOL)** - 121 -

16. **TCP/IP** - 121 -

17. **UDP (USER DATAGRAM PROTOCOL)**..... - 121 -

APPENDIX C: ACTUAL BAUD RATE MEASUREMENT- 122 -

APPENDIX D: REVISION HISTORY- 123 -

Packing List

The tGW-700 shipping package includes the following items:



tGW-700 Series



Quick Start



CA-002 Cable

The tGW-700-T shipping package includes the following items:



tGW-700-T Series



Quick Start

The GW-2200 shipping package includes the following items:



GW-2200 Series



Quick Start

Note

If any of these items are missing or damaged, please contact the local distributor for more information. Save the shipping materials and cartons in case you need to ship the module in the future.

More Information

- **Documentation**

[tGW-700 Series / tGW-700-T Series](#)

<https://www.icpdas.com/en/download/index.php?nation=US&kind1=&model=&kw=tGW-700>

[GW-2200 Series](#)

<https://www.icpdas.com/en/download/index.php?nation=US&kind1=&model=&kw=GW-2200>

- **Firmware**

[tGW-700 Series / tGW-700-T Series](#)

<https://www.icpdas.com/en/download/show.php?num=2417>

[GW-2200 Series](#)

<https://www.icpdas.com/en/download/show.php?num=2750>

- **Software**

[eSearch Utility](#)

https://www.icpdas.com/en/product/guide+Software+Utility_Driver+eSearch_Utility

[EtherDOT](#)

https://www.icpdas.com/en/product/guide+Software+Utility_Driver+EtherDOT

1. Introduction

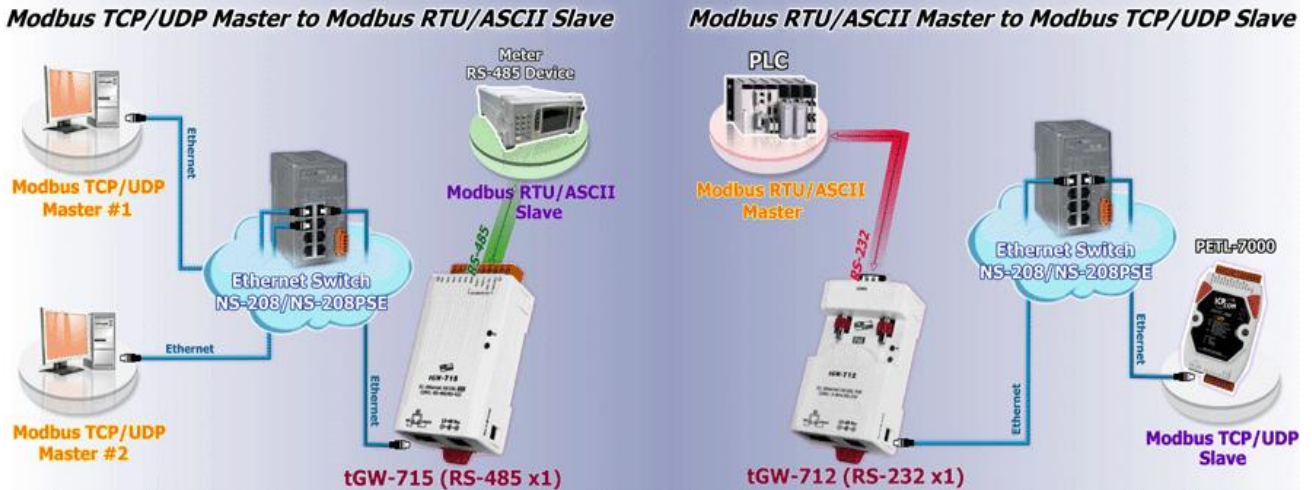

Modbus has become the de facto standard protocol for industrial communication, and is now the most commonly available means of connecting industrial electronic devices. Modbus allows for communication between many devices connected to the same RS-485 network, for example, a system that measures temperature and humidity and communicates the results to a computer. Modbus is often used to connect a supervisory computer with a remote terminal unit (RTU) in supervisory control and data acquisition (SCADA) systems.

The tGW-700/GW-2200 module is a Modbus TCP/UDP to RTU/ASCII gateway that enables a Modbus TCP/UDP host to communicate with serial Modbus RTU/ASCII devices through an Ethernet network, and eliminates the inherent cable length limitations of legacy serial communication devices. The module can be used to create pair-connection applications (as well as serial-bridge or serial-tunnel applications), and can then route data over a TCP/IP connection between two serial Modbus RTU/ASCII devices, which is useful when connecting mainframe computers, servers or other serial devices that use Modbus RTU/ASCII protocols and do not themselves have Ethernet capability. And the tGW-700/GW-2200 adopts the dual-stack technology to support the IPv4 and IPv6 simultaneously (version 2.2.0 or later).

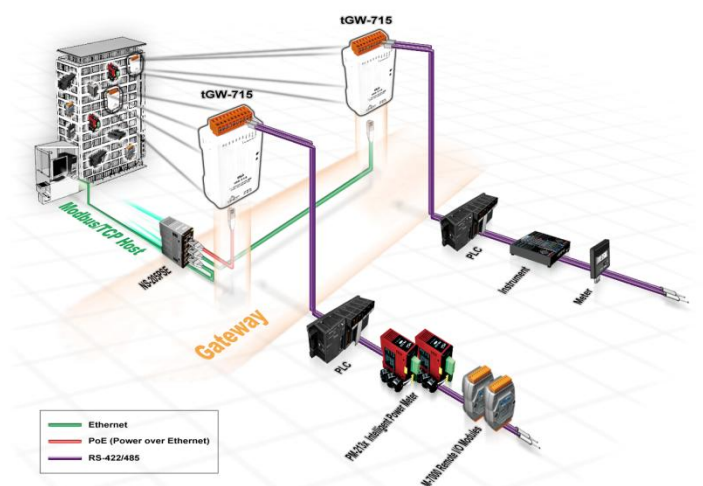

In harsh industrial environments, the tGW-700/GW-2200 series (for i version) also adds 3000 V_{DC} and ± 4 kV ESD protection component that diverts the potentially damaging charge away from sensitive circuit to protects the module and equipment from the sudden and momentary electric current.

The tGW-700/GW-2200 module features a powerful 32-bit MCU that enables efficient handling of network traffic, and also has a built-in web server that provides an intuitive web management interface that allows users to modify the configuration of the module, including the DHCP/Static IP, the gateway/mask settings and the serial port settings.



The tGW-700/GW-2200 module offers true IEEE 802.3af-compliant (classification, Class 1) Power over Ethernet (PoE) functionality using a standard Category 5 Ethernet cable to receive power from a PoE switch, such as the NS-205PSE. If there is no PoE switch on site, the module will also accept power input from a DC adapter. The tGW-700/GW-2200 module is designed for ultra-low power consumption, reducing the hidden costs resulting from increasing fuel and electricity prices, especially when a large number of modules are installed. Reducing the amount of electricity consumed by choosing energy-efficient equipment can also have a positive impact on maintaining a green environment.

Comparison of Modules:

Series Features	PPDS-700	PDS-700	DS-700	tDS-700 DS-2200	tGW-700 GW-2200	tGW-700-T
	Virtual COM	✓	✓	✓	✓	-
Programmable	✓	✓	-	-	-	-
PoE	✓	-	-	✓	✓	-
Modbus Gateway	✓	-	-	-	✓	✓
Multi-client	About 20 Sockets			1 Sockets/Port	tGW-700 RevB/GW-2200: 32 Sockets/port tGW-700 Non-RevB: 10 Sockets/port	32 Sockets/port
Remarks	Professional	Powerful	Isolation for DS-715	Cost-effective, Entry-level	Cost-effective, Entry-level	Cost-effective, Entry-level

1.1 Features

- Supports Modbus TCP/UDP master and slave
- Supports Modbus RTU/ASCII master and slave
- Max. connections (masters) per serial port:
32 for tGW-700 RevB version, tGW-700-T Series, GW-2200 Series
32 (tGW-71x), 16 (tGW-72x) or 10 (tGW-73x) for tGW-700 Non-RevB version
- Read-cache ensures faster Modbus TCP/UDP response
- Supports UDP responder for device discovery (UDP Search)
- Static IP or DHCP network configuration for IPv4
- Link-local Address and SLAAC(Stateless address auto-configuration) for IPv6
- Supports IPv4 and IPv6 simultaneously with dual-stack
- Easy firmware update via the Ethernet (BOOTP, TFTP)
- Tiny Web server for configuration (HTTP)
- Contains a 32-bit MCU that efficiently handles network traffic
- 10/100 Base-TX Ethernet, RJ-45 x1 (Auto-negotiating, auto MDI/MDIX, LED Indicators)
- GW-2200 series supports 2-port Ethernet Switch (LAN Bypass) for Daisy-chain wiring
- Includes redundant power inputs: PoE (IEEE 802.3af, Class 1) and DC jack

Note: tGW-700-T series don't support PoE.

- Allows automatic RS-485 direction control
- Power or Signal isolation for i versions
- ± 4 kV ESD protection
- Male DB-9 or terminal block connector for easy wiring
- Tiny form-factor and low power consumption
- RoHS compliant with no Halogen
- Cost-effective Modbus Gateway

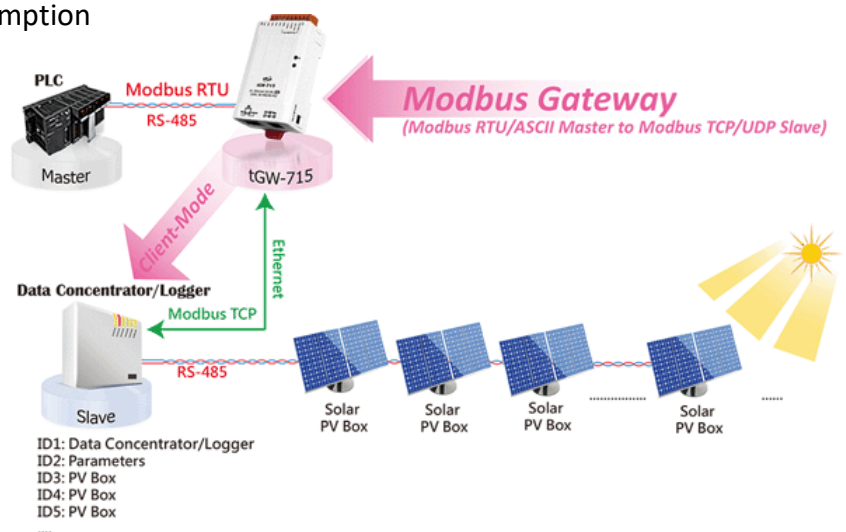

1.2 Applications

- Factory Automation
- Building Automation
- Home Automation
- Remote Diagnosis and Management

1.3 Ethernet Solutions

Nowadays, the Ethernet protocol has become the foremost standard for local area networks. Connectivity via the Internet snow common in many of the latest applications from home appliances, to vending machines, to testing equipment, to UPS, etc. An Ethernet network can link office automation and industrial control networks, access remote systems and share data and information between machines from multiple vendors, and also provides a cost-effective solution for industrial control networks.



1.4 Web Server Technology

Web server technology enables the tGW-700/GW-2200 to be configured via a standard web browser interface, e.g., Google Chrome, Microsoft Edge, Mozilla Firefox or Apple Safari. This means that it is easy to check the configuration of the tGW-700/GW-2200 via an Ethernet network without needing to install any other software tools, thereby reducing the learning curve required for maintaining the device.

The screenshot shows the Tiny Modbus Gateway web interface in a browser window. The address bar shows 10.0.8.100. The page title is "Tiny Modbus Gateway" with the ICP DAS logo. Navigation links include Home, Port1, Network, Filter, SNMP, Monitor, Password, and Logout. The main content area displays device information in two columns:

Model Name	tGW-718i-D_RevB	Alias Name	Tiny
Firmware Version	B2.3.9 [Jul.11 2023]	MAC Address	00-0d-e0-f7-18-d0
IP Address	10.0.8.100	TCP Port Timeout (Socket Watchdog, Seconds)	180
Initial Switch	OFF	System Idle (Network Watchdog, Seconds)	300

Below this is the "Current port settings:" section, which contains three sub-tables:

Interface Settings		Port 1
Interface		RS-232
Pull-High/Low Resister		-
Terminal Resister		-

Port Settings		Port 1
Baud Rate (bps)		115200,8N1
Flow Control		None
Protocol		RTU
Slave Timeout (ms)		300
Char Timeout (bytes)		4
Silent Time (ms)		0
Read Cache (ms)		980
Connection Idle (Seconds)		180
Local TCP Port		502
Virtual ID Range		0-247
Virtual ID Offset		0

Pair-Connection Settings (Master/Slave Mode)		Port 1
Application Mode		TCP/UDP Server
Remote Server IP		-
Remote TCP Port		-

Copyright © 2023 ICP DAS Co., Ltd. All rights reserved.

2. Hardware Information

This chapter provides a detailed description of the front panel, the hardware specifications, the pin assignments, the wiring notes and the dimensions for the tGW-700/GW-2200 series modules.

2.1 Specifications

Model	tGW series	tGW-712 tGW-712i	tGW-722 tGW-722i	tGW-732 tGW-732i	tGW-715 tGW-715i tGW-715-T tGW-715i-T	tGW-725 tGW-725i	tGW-735 tGW-735i	tGW-718 tGW-718i tGW-718-D tGW-718-T tGW-718i-T	tGW-724 tGW-724i	tGW-734 tGW-734i
	GW series	GW-2212i	GW-2222i	GW-2232i	GW-2215i	GW-2225i	GW-2235i			
System										
CPU		32-bit ARM								
Communication Interface										
Ethernet	700 (-T) Series	10/100 Base-TX, 8-pin RJ-45 x 1, (Auto-negotiating, Auto-MDI/MDIX, LED indicator)								
	2200 Series	2-Port 10/100 Base-TX Ethernet Switch with LAN Bypass, RJ-45 x 2 (Auto-negotiating, Auto-MDI/MDIX, LED indicator)								
PoE	700 Series	IEEE 802.3af, Class 1								
	2200 Series									
	700-T Series									
COM Port	700 (-T)Series	1 x RS-232	2 x RS-232	3 x RS-232	1 x RS-422/ RS-485	2 x RS-485	3 x RS-485	1 x RS-232 or RS-422/485	1 x RS-485	1 x RS-485
	2200 Series					2 x RS-422/ RS-485	3 x RS-422/ RS-485			
Self-Tuner		-			Yes, automatic RS-485 direction control					
RS-485	Bias Resistor	-			Yes, 1 KΩ					
	Node	-			254 (max.)					
UART		16c550 or compatible								
Power Isolation		1000 V _{DC} for tGW-722i/ 732i/ 718i-D , GW-2212i / 2222i / 2232i								
Signal Isolation		3000 V _{DC} for tGW-712i/ 715i/ 725i/ 735i/ 718i/ 724i/ 734i/715i-T/718i-T , GW-2215i / 2225i / 2235i								
ESD Protection		± 4 kV								
COM Port Format										
Baud Rate		115200 bps Max.								
Data Bit		5, 6, 7, 8								
Parity		None, Odd, Even, Mark, Space								
Stop Bit		1, 2								
Power										
Power Input		PoE: IEEE 802.3af, Class 1 (except tGW-700-T Series), DC jack: +12 ~ 48 V _{DC}								
Power Consumption		0.07 A @ 24 V _{DC}								
Mechanism										
Connector	700 (-T) Series	Male DB-9 x1 for tGW-712(i)/718i-D 10-Pin Removable Terminal Block x 1 for tGW-722(i)/732(i)/715(i)/725(i)/735(i)/718(i)/724(i)/734(i)/715(i)-T/718(i)-T								
	2200 Series	5-pin Removable Terminal Block x 1 for 2212i/2215i; x 2 for 2222i/2225i; x 3 for 2232i/2235i								
Mounting		DIN-Rail								
Flammability		Fire Retardant Materials (UL94-V0 Level)								
Environment										
Operating Temperature		-25 ~ +75 °C								
Storage Temperature		-30 ~ +80 °C								
Humidity		10 ~ 90% RH, non-condensing								
Note: COM1/COM2/COM3 = TCP Port 502/503/504										

2.2 Appearance

➤ tGW-700 Series

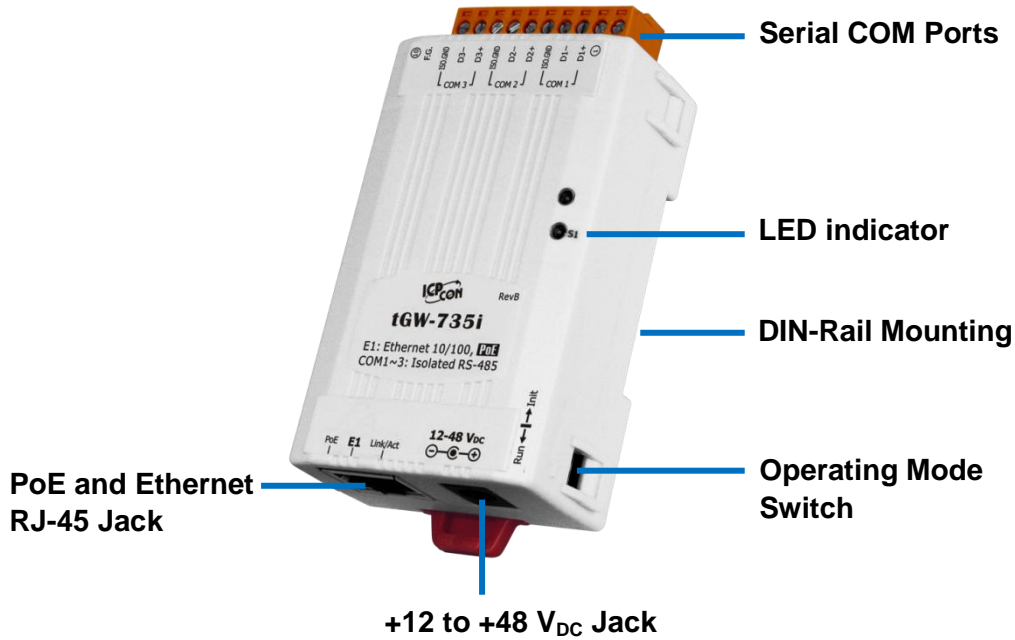

➤ tGW-700-T Series

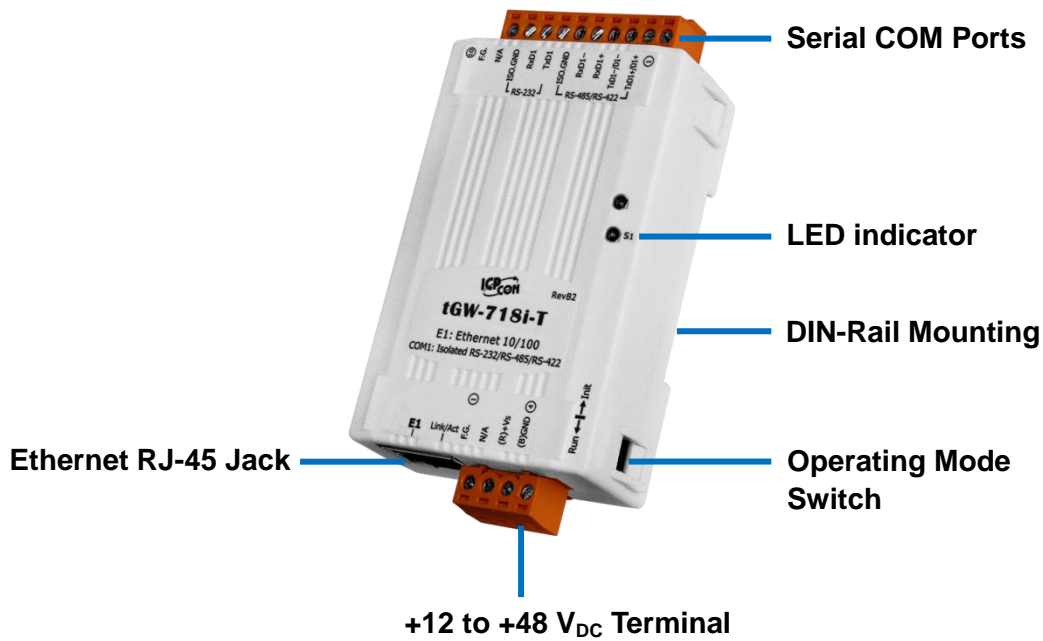

➤ **GW-2200 Series**

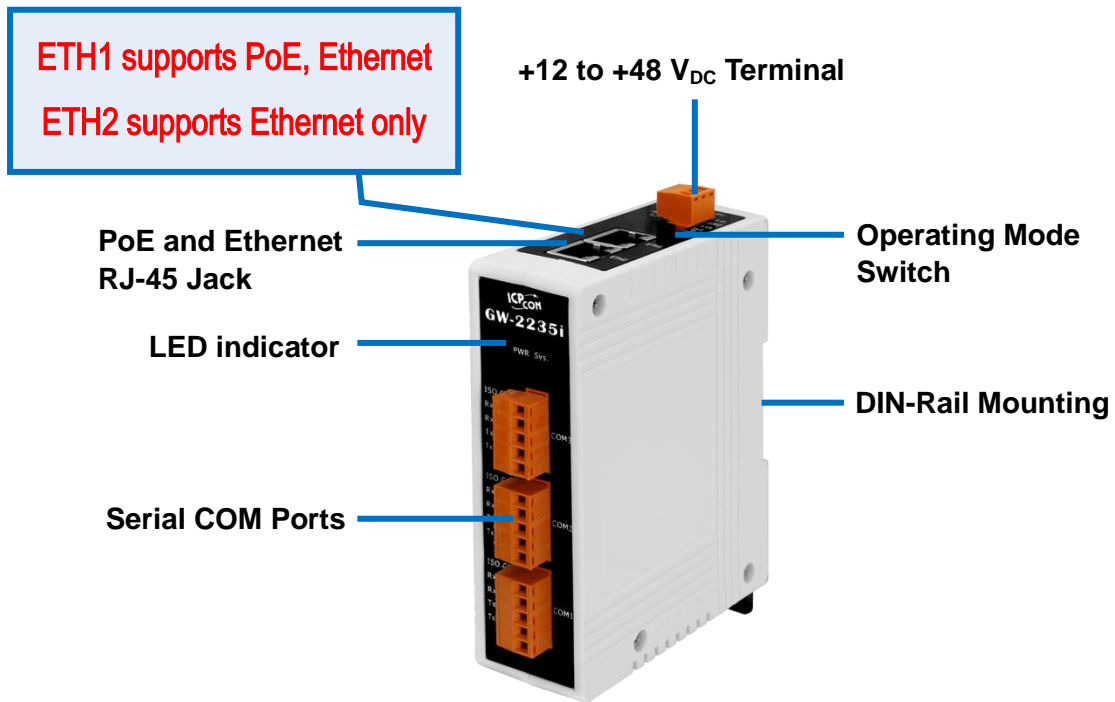

PoE and Ethernet RJ-45 Jack

The tGW-700 module is equipped with an RJ-45 jack that is used as the 10/100 Base-TX Ethernet port and features networking capabilities, supports PoE power supply (except tGW-700-T Series). The GW-2200 series module is equipped with two RJ-45 jacks that are used as the 10/100 Base-TX Ethernet port and features networking capabilities, only ETH1 supports PoE power supply. When an Ethernet link is detected and an Ethernet packet is received, the **Link/Act LED (Orange)** indicator will be illuminated. When power is supplied via PoE (Power-over-Ethernet), the **PoE LED (Green)** indicator will be illuminated.

+12 to +48 V_{DC} Jack

The tGW-700 is equipped with a +12V_{DC} to +48 V_{DC} jack that can be used to connect a power supply. The tGW-700-T series and the GW-2200 series is equipped with a +12V_{DC} to +48 V_{DC} terminal that can be used to connect a power supply. If no PoE switch is available on site, a DC adapter can be used to power the tGW-700/GW-2200 module.

Operating Mode Switch

Run Mode: Firmware operation

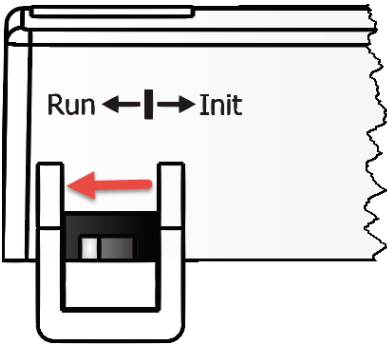

Init Mode: Configuration mode

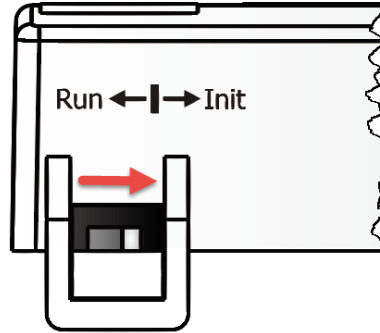







For tGW-700/GW-2200 series modules, the operating mode switch is in the **Run** position by default. In order to update the firmware for the tGW-700/GW-2200 series module, the switch must be moved from the **Run** position to the **Init** position. The switch must be returned to the Run position after the update is complete.

LED Indicator

Once power is supplied to the tGW-700/GW-2200 series module, the system LED indicator will illuminate. An overview of the system LED functions is given below:

Function	Color	S1 LED Behavior
Running Firmware		Steady ON
Network Ready	Red  S1	Slow flashing – Once every 3 seconds
Serial Port Busy		Rapid flashing – Once every 0.2 seconds

The following serial port LED indicators are tGW-718i-D only. You can change the serial interface via web server. An overview of the serial Port LED functions is given below:

Function	RS-232	RS-485	RS-422
LED Behavior	R  S1 G 232 R  485 G 422	R  S1 G 232 R  485 G 422	R  S1 G 232 R  485 G 422

Serial COM Ports

The number of serial COM Ports available depends on the type of tGW-700/GW-2200 module. For more detailed information regarding the pin assignments for the Serial COM ports, refer to [Section 2.4 Pin Assignments](#).

DIN-Rail Mounting

The tGW-700/GW-2200 series modules include simple rail clips on the bottom of the chassis that allow them to be reliably mounted on a DIN-Rail or a wall. For more detailed information regarding DIN-Rail Mounting, refer to the illustration in figure below.

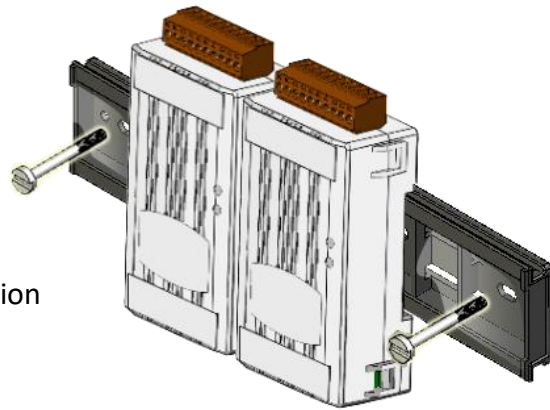

Mounting on a DIN-Rail

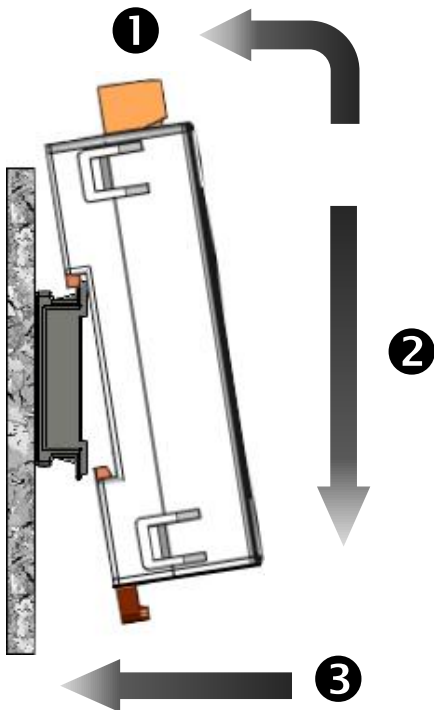

Dismounting from a DIN-Rail

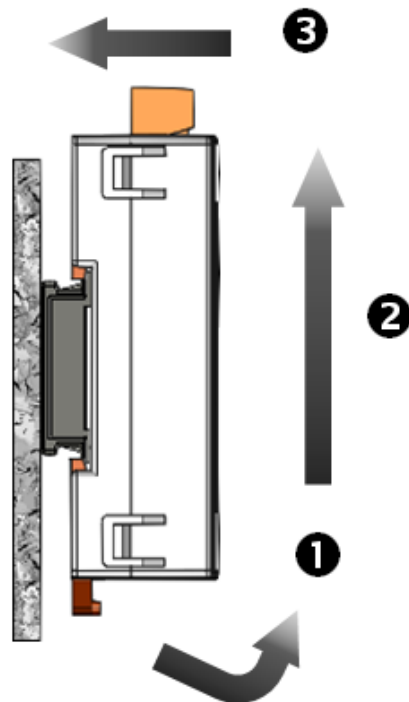

2.3 Dimensions

The following diagrams provide the dimensions of the tGW-700/GW-2200 series module and CA-002 cable that can be used as a reference when defining the specifications and the DC power supply plug for any custom enclosures. All dimensions are in millimeters.

tGW-700 Series Module (Unit: mm)

➤ **tGW-712:**

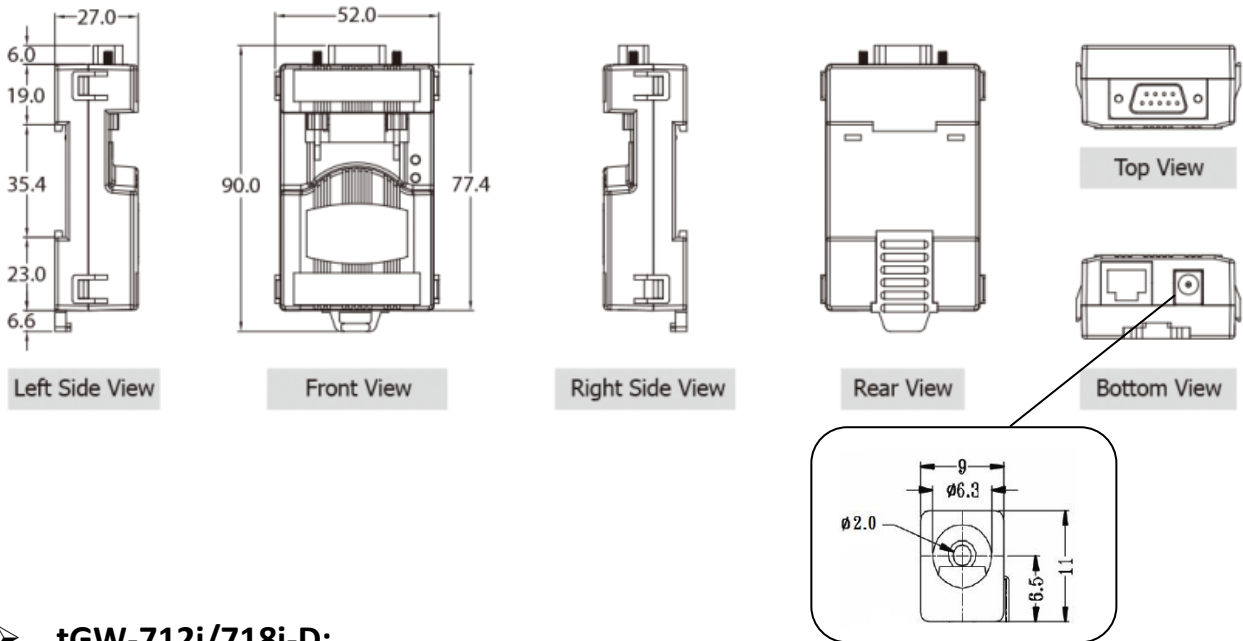

➤ **tGW-712i/718i-D:**

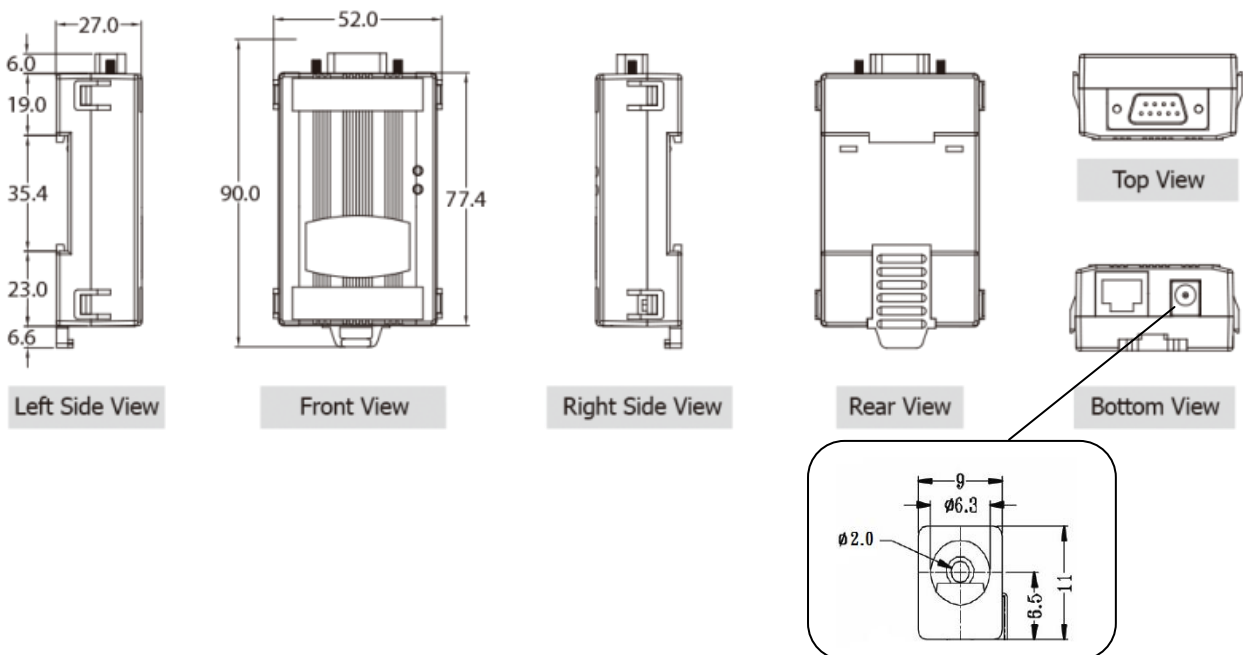

tGW-700-T Series Module (Unit: mm)

➤ tGW-715(i)-T/718(i)-T:

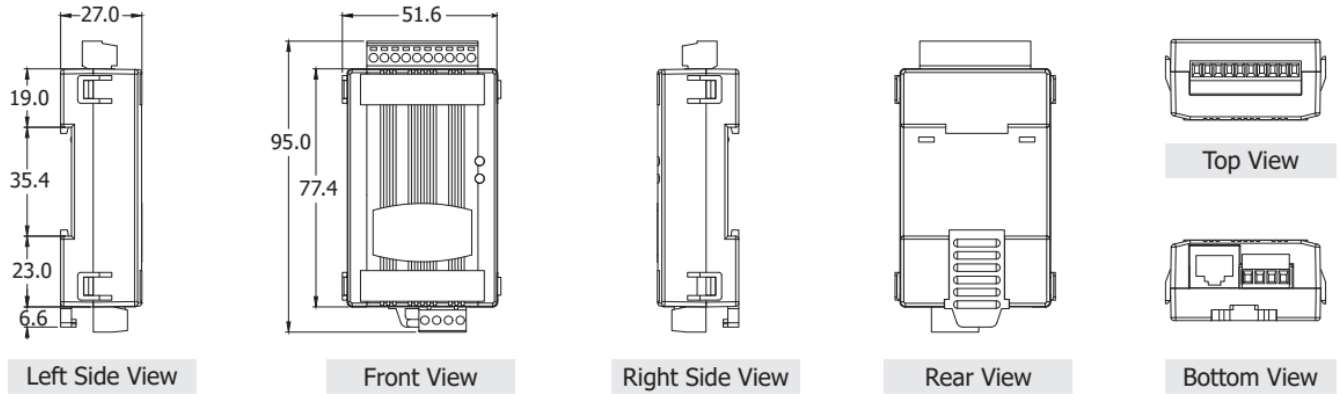

GW-2200 Series Module (Unit: mm)

➤ **GW-2212i/2222i/2232i/2215i/2225i/2235i**

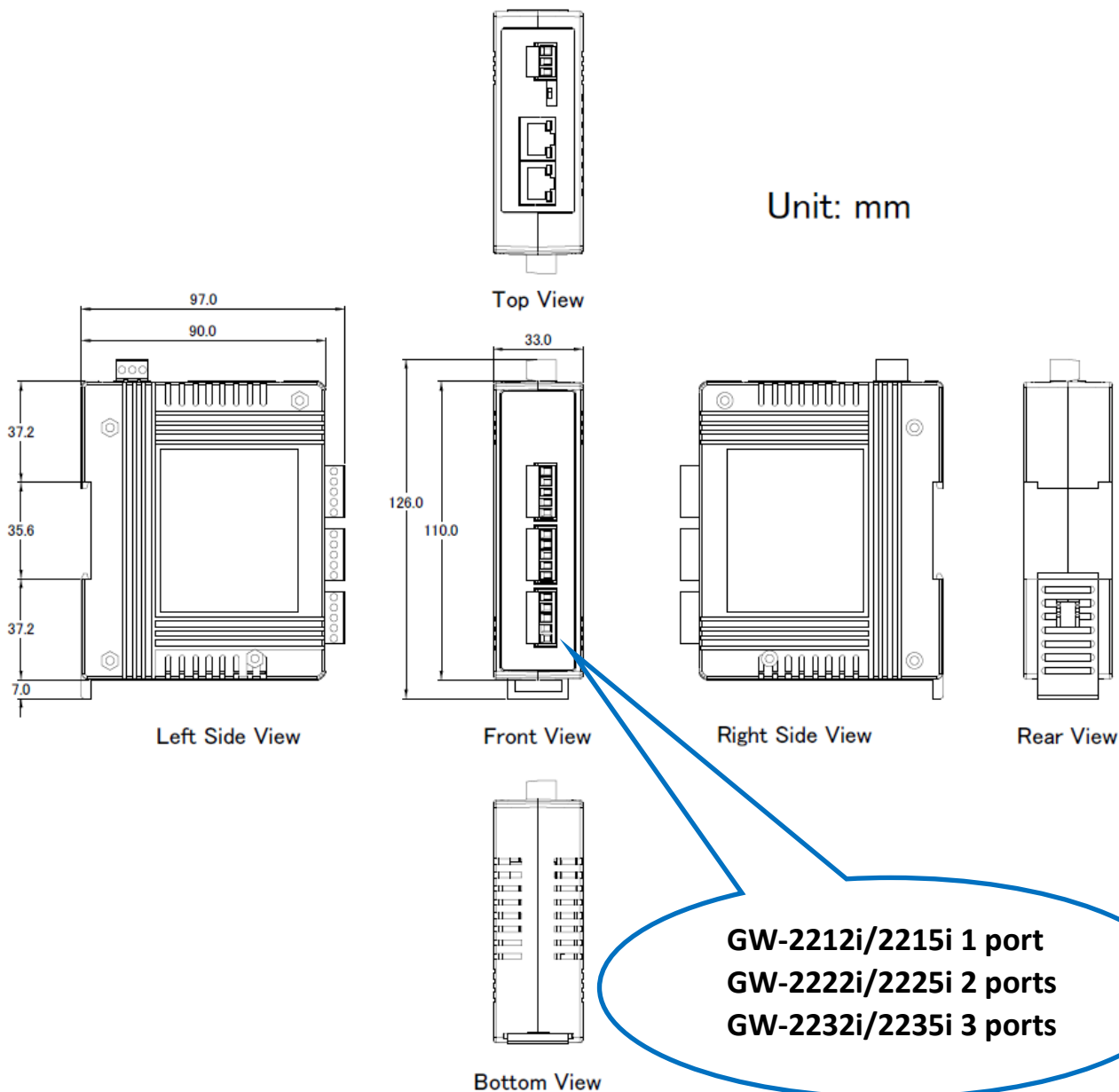

2.4 Pin Assignments

tGW-712/tGW-712i

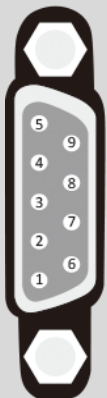
Terminal No.		tGW-712	tGW-712i
	09	N/A	N/A
	08	CTS1	CTS1
	07	RTS1	RTS1
	06	N/A	N/A
	05	GND	ISO.GND
	04	N/A	N/A
	03	TxD1	TxD1
	02	RxD1	RxD1
	01	N/A	N/A

Note: The CTS/RTS pins for flow control are supported after the firmware version B1.5.6 only.

tGW-722/tGW-722i

Terminal No.		tGW-722	tGW-722i
	10	F.G.	F.G.
COM2	09	CTS2	CTS2
	08	RTS2	RTS2
	07	RxD2	RxD2
	06	TxD2	TxD2
COM1	05	GND	ISO.GND
	04	CTS1	CTS1
	03	RTS1	RTS1
	02	RxD1	RxD1
	01	TxD1	TxD1

Note: The CTS/RTS pins for flow control are supported after the firmware version B1.5.6 only.

tGW-732/tGW-732i

		tGW-732	tGW-732i
Terminal No.		Pin Assignment	
	10	F.G.	F.G.
COM3	09	GND	ISO.GND
	08	RxD3	RxD3
	07	TxD3	TxD3
COM2	06	GND	ISO.GND
	05	RxD2	RxD2
	04	TxD2	TxD2
COM1	03	GND	ISO.GND
	02	RxD1	RxD1
	01	TxD1	TxD1

tGW-715/tGW-715i/tGW-715-T/tGW-715i-T

		tGW-715/ tGW-715-T		tGW-715i / tGW-715i-T	
Terminal No.		Pin Assignment			
		RS-485	RS-422	RS-485	RS-422
	10	F.G.		F.G.	
	09	N/A		N/A	
	08	N/A		N/A	
	07	N/A		N/A	
	06	N/A		N/A	
COM1	05	GND		ISO.GND	
	04	N/A	RxD1-	N/A	RxD1-
	03	N/A	RxD1+	N/A	RxD1+
	02	D1-	TxD1-	D1-	TxD1-
	01	D1+	TxD1+	D1+	TxD1+

tGW-725/tGW-725i

		tGW-725	tGW-725i
Terminal No.		Pin Assignment	
	10	F.G.	F.G.
	09	N/A	N/A
	08	N/A	N/A
	07	N/A	N/A
COM2	06	GND	ISO.GND
	05	D2-	D2-
	04	D2+	D2+
COM1	03	GND	ISO.GND
	02	D1-	D1-
	01	D1+	D1+

tGW-735/tGW-735i

		tGW-735	tGW-735i
Terminal No.		Pin Assignment	
	10	F.G.	F.G.
COM3	09	GND	ISO.GND
	08	D3-	D3-
	07	D3+	D3+
COM2	06	GND	ISO.GND
	05	D2-	D2-
	04	D2+	D2+
COM1	03	GND	ISO.GND
	02	D1-	D1-
	01	D1+	D1+

tGW-718/tGW-718i/tGW-718-T/tGW-718i-T

Terminal No.		tGW-718/ tGW-718-T		tGW-718i/ tGW-718i-T	
Terminal No.		Pin Assignment			
	10	F.G.		F.G.	
	09	N/A		N/A	
RS-232	08	GND		ISO.GND	
	07	RxD1		RxD1	
	06	TxD1		TxD1	
RS-485/RS-422	05	GND		ISO.GND	
	04	N/A	RxD1-	N/A	RxD1-
	03	N/A	RxD1+	N/A	RxD1+
	02	D1-	TxD1-	D1-	TxD1-
	01	D1+	TxD1+	D1+	TxD1+

tGW-718i-D

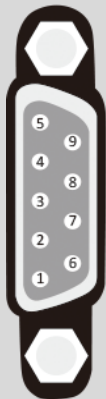
Terminal No.		RS-232	RS-422	RS-485
Terminal No.		Pin Assignment		
COM1 	09	-	-	-
	08	CTS	-	-
	07	RTS	-	-
	06	-	-	-
	05	GND	GND	GND
	04	-	RxD-	-
	03	TxD	RxD+	-
	02	RxD	TxD+	Data+
	01	-	TxD-	Data-

tGW-724/tGW-724i

Terminal No.		tGW-724	tGW-724i
Terminal No.		Pin Assignment	
	10	F.G.	F.G.
	09	GND	ISO.GND
COM2	08	CTS2	CTS2
	07	RTS2	RTS2
	06	GND	ISO.GND
	05	RxD2	RxD2
	04	TxD2	TxD2
COM1	03	GND	ISO.GND
	02	D1-	D1-
	01	D1+	D1+

Note: The CTS/RTS pins for flow control are supported after the firmware version B1.5.6 only.

tGW-734/tGW-734i

Terminal No.		tGW-734	tGW-734i
Terminal No.		Pin Assignment	
	10	F.G.	F.G.
COM3	09	GND	ISO.GND
	08	RxD3	RxD3
	07	TxD3	TxD3
COM2	06	GND	ISO.GND
	05	RxD2	RxD2
	04	TxD2	TxD2
COM1	03	GND	ISO.GND
	02	D1-	D1-
	01	D1+	D1+

GW-2212i/2222i/2232i

		GW-2212i	GW-2222i	GW-2232i
Terminal No.		Pin Assignment		
COM3	05	--	--	ISO.GND
	04	--	--	RTS3
	03	--	--	CTS3
	02	--	--	RxD3
	01	--	--	TxD3
COM2	05	--	ISO.GND	ISO.GND
	04	--	RTS2	RTS2
	03	--	CTS2	CTS2
	02	--	RxD2	RxD2
	01	--	TxD2	TxD2
COM1	05	ISO.GND	ISO.GND	ISO.GND
	04	RTS1	RTS1	RTS1
	03	CTS1	CTS1	CTS1
	02	RxD1	RxD1	RxD1
	01	TxD1	TxD1	TxD1

GW-2215i/2225i/2235i

		GW-2215i		GW-2225i		GW-2235i	
Terminal No.		Pin Assignment					
		RS-485	RS-422	RS-485	RS-422	RS-485	RS-422
COM3	05	--	--	--	--	ISO.GND	
	04	--	--	--	--	--	RxD3-
	03	--	--	--	--	--	RxD3+
	02	--	--	--	--	D3-	TxD3-
	01	--	--	--	--	D3+	TxD3+
COM2	05	--	--	ISO.GND		ISO.GND	
	04	--	--	--	RxD2-	--	RxD2-
	03	--	--	--	RxD2+	--	RxD2+
	02	--	--	D2-	TxD2-	D2-	TxD2-
	01	--	--	D2+	TxD2+	D2+	TxD2+
COM1	05	ISO.GND		ISO.GND		ISO.GND	
	04	--	RxD1-	--	RxD1-	--	RxD1-
	03	--	RxD1+	--	RxD1+	--	RxD1+
	02	D1-	TxD1-	D1-	TxD1-	D1-	TxD1-
	01	D1+	TxD1+	D1+	TxD1+	D1+	TxD1+

2.5 Wiring Notes for RS-232/485/422 Interfaces

RS-232 Wiring

3-wire RS-232 Connection

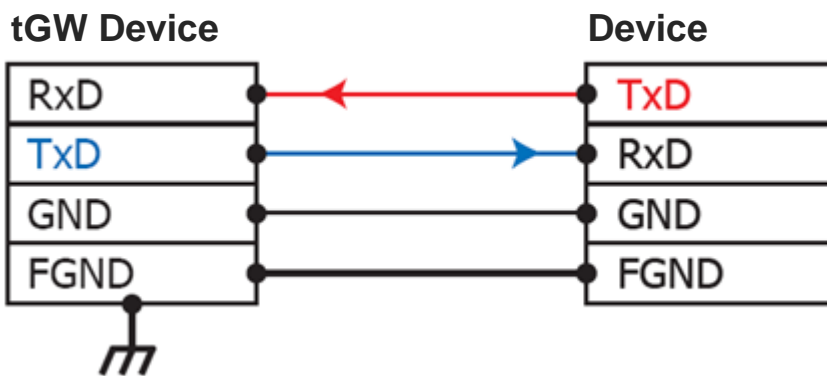

5-wire RS-232 Connection

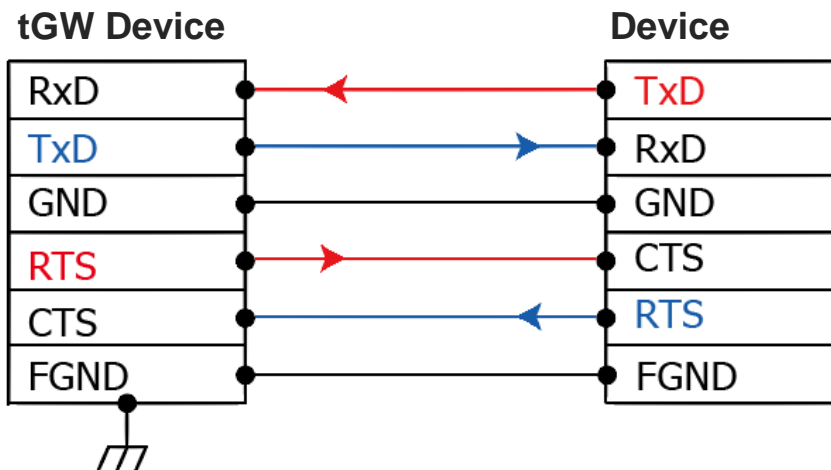

Note: FGND is the frame ground that is soldered to the metal shield on the DB-9 cable.

RS-422 Wiring

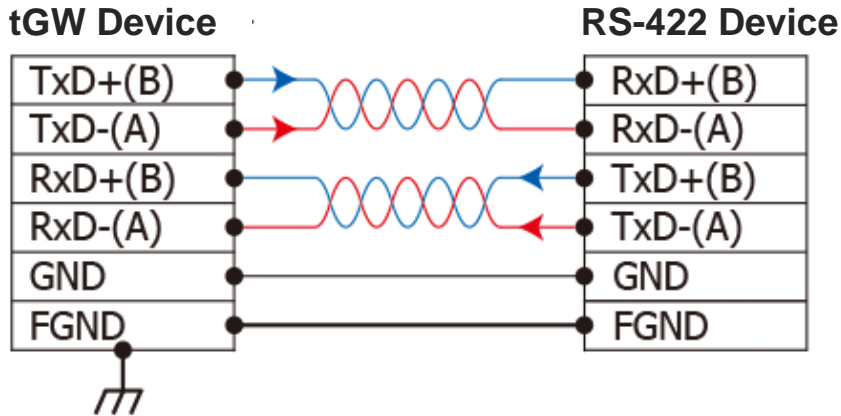

RS-485 Wiring

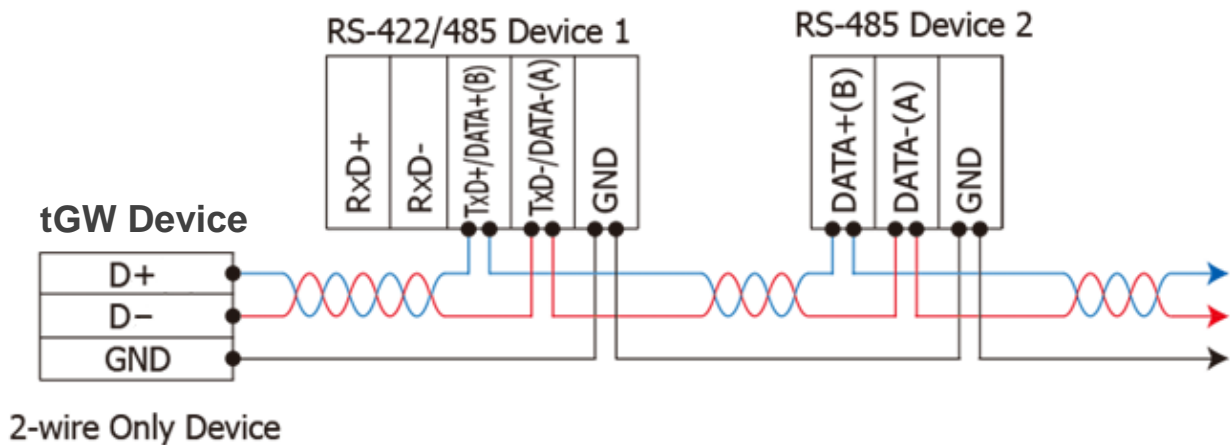

Notes:

1. Usually, you have to connect all signal grounds of RS-422/485 devices together to reduce common-mode voltage between devices.
2. Twisted-pair cable must be used for the D+/D- (or DATA+/ DATA-) wires.
3. Both two ends of the cable may require a termination resistor connected across the two wires (D+ and D-). Typically 120 Ω resistors are used.
4. The D+ and B pins are positive-voltage pins, and the D- and A pins are negative-voltage pins in the above figure. The B/A pins may be defined in another way depending on devices, please check it first.

3. Getting Started for tGW-700 / GW-2200 series on IPv4

This chapter provides detailed information about the “Self-Test” process, which is used to confirm that the tGW-700/GW-2200 series module is operating correctly. Before beginning the “Self-Test” process, the wiring test, Ethernet configuration and eSearch/Modbus utility driver installation procedures must first be fully completed. Follow the procedure described below:

Note: This chapter is based on IPv4 environment.

3.1 Connecting the Power and Host PC

1. Ensure that the network settings on your PC are configured correctly.
Ensure that the Windows firewall or any Anti-Virus firewall software is correctly configured or temporarily disable these functions; otherwise the “Search Servers” function in the eSearch Utility may not work as required. You may need to contact your System Administrator for more details of how to do this.

2. Check that the **Init/Run switch** is in the “Run” position.

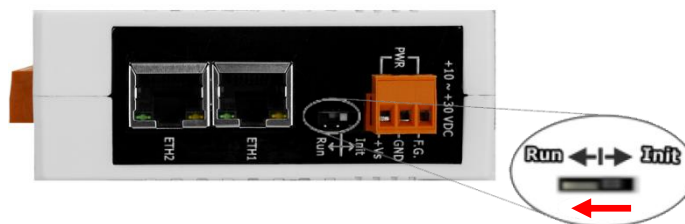
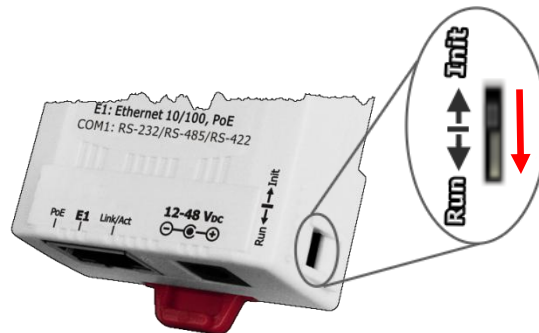

3. Connect both the tGW-700/GW-2200 and the Host computer to the same sub-network or the same Ethernet Switch, and then supply power (PoE or +12 to +48 Vdc) to the tGW-700/GW-2200.

PoE Power Supply

Note: tGW-700-T series don't support PoE.

tGW-700 Series

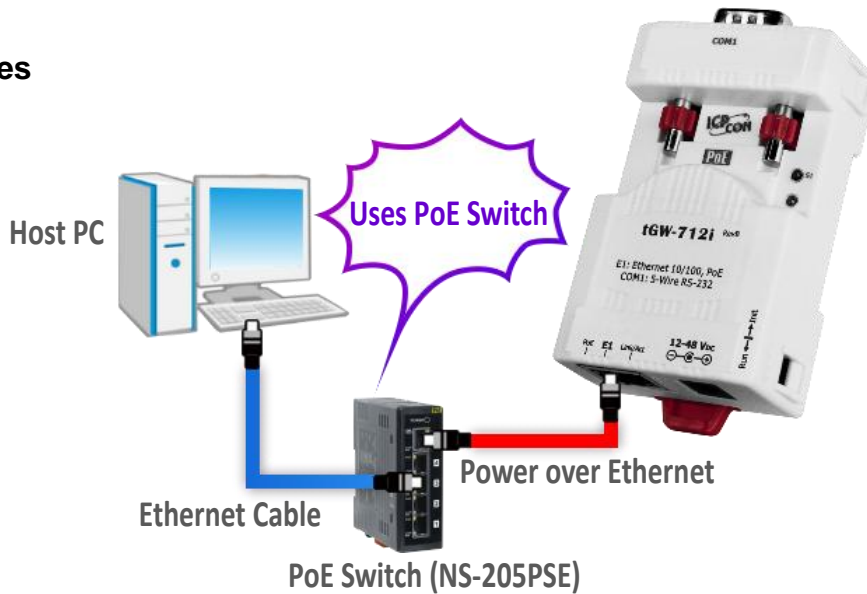

GW-2200 Series

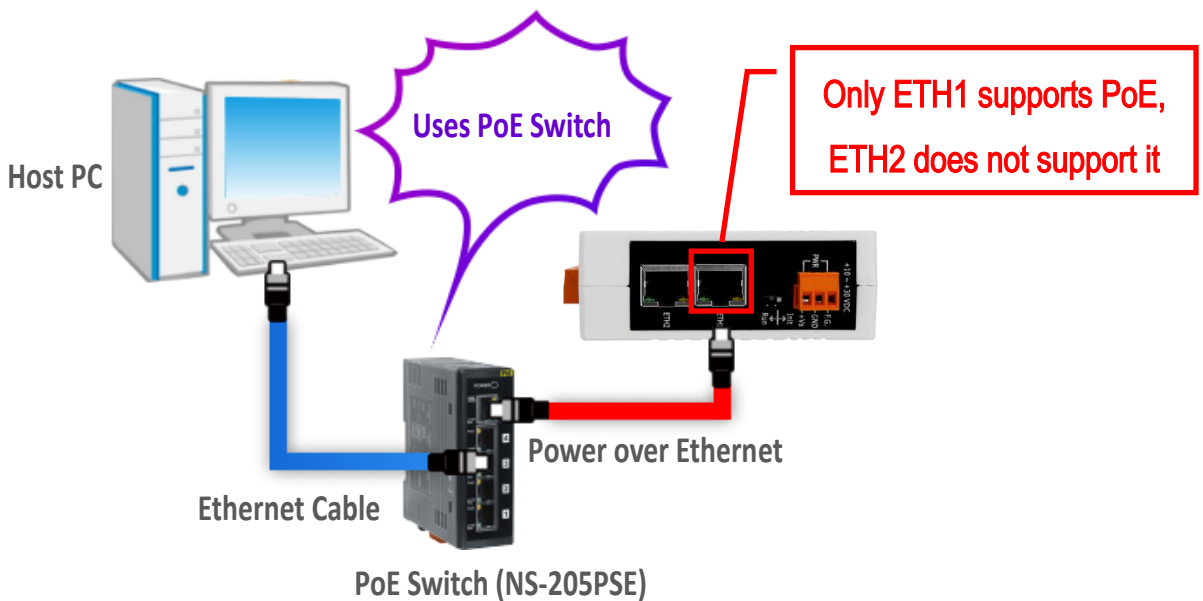

+12 to +48 VDC Jack Power Supply (Non-PoE)

tGW-700 Series

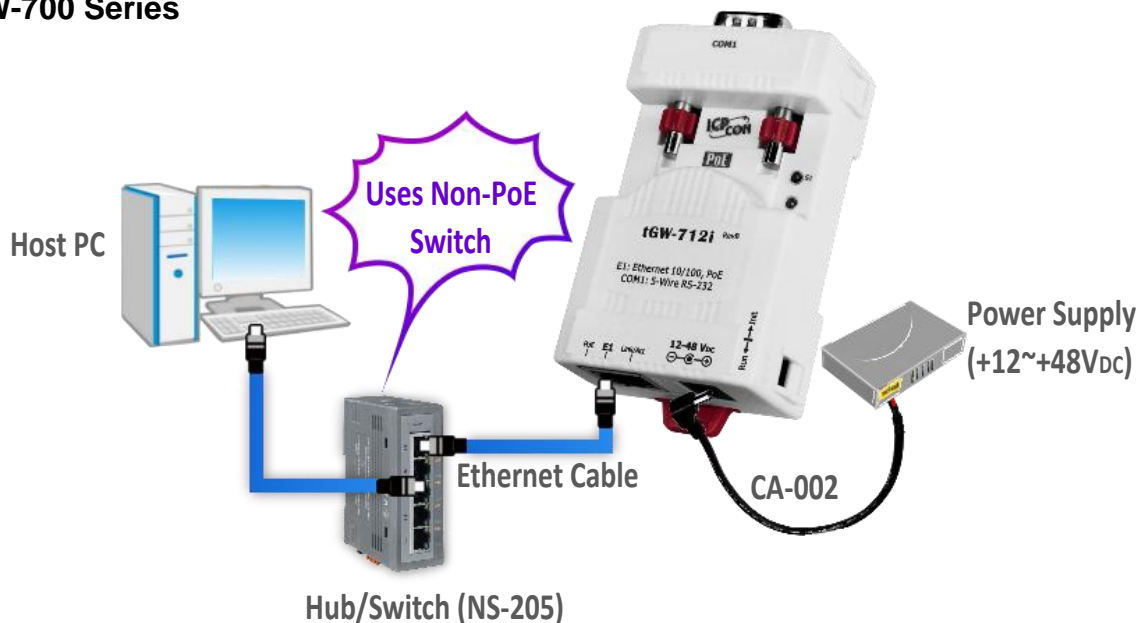

tGW-700-T Series

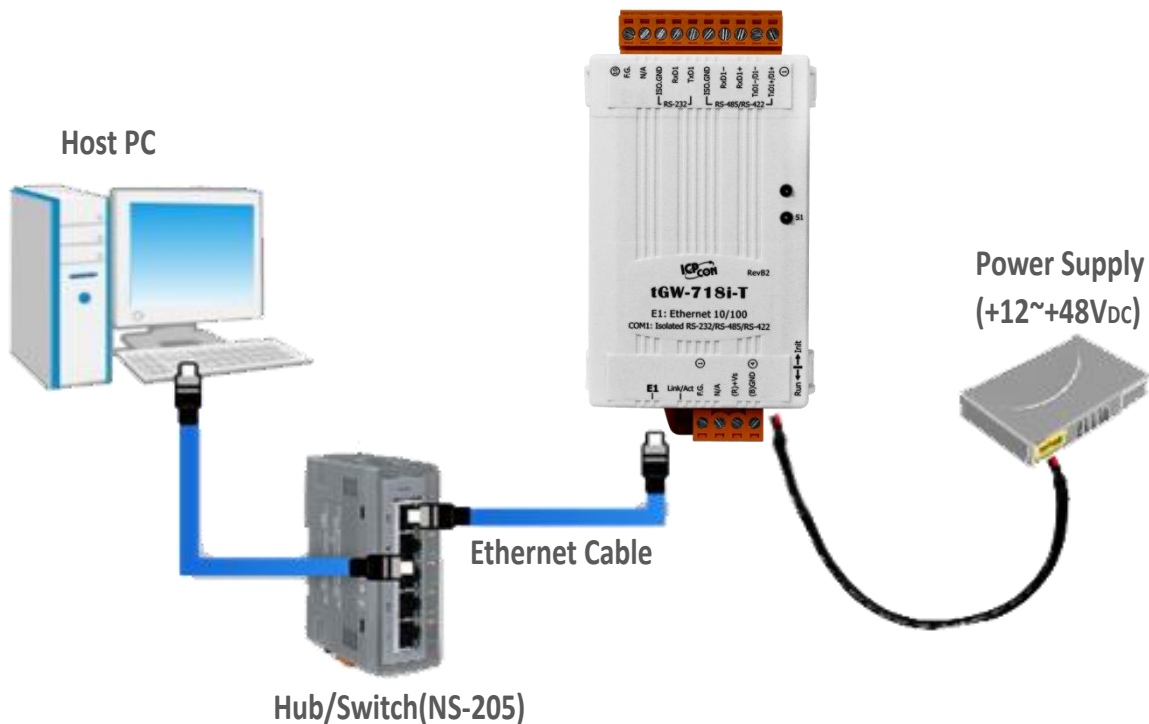

GW-2200 Series

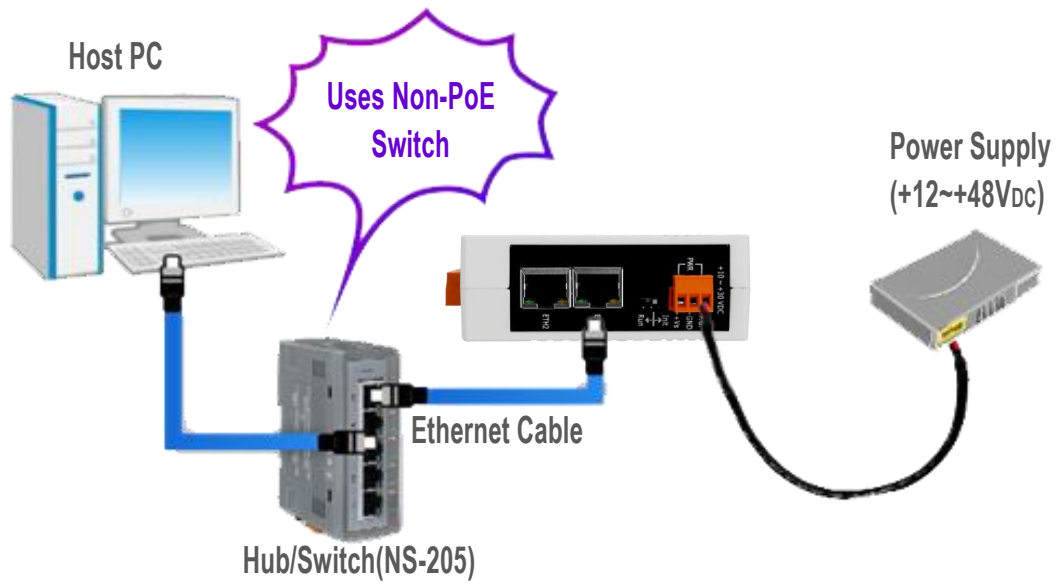

4. Verify that the System (S1) LED indicator is flashing.

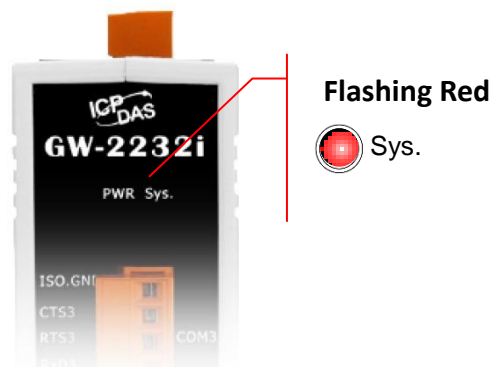
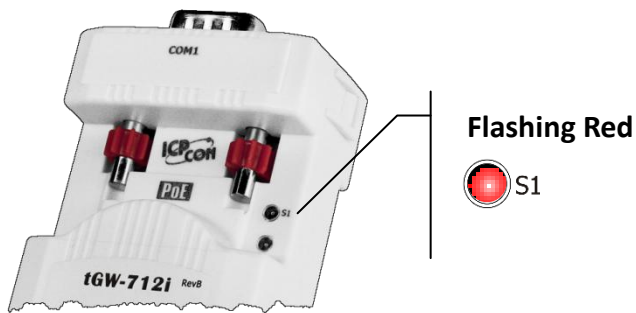

3.2 Configuring Network Settings

1. Download the **eSearch Utility** and install it according to the installation instructions.



eSearch_v1.1.13
_setup.exe

The eSearch Utility can be downloaded from the ICP DAS web site.

 https://www.icpdas.com/en/product/guide+Software+Utility_Driver+eSearch_Utility

2. Double click the **eSearch Utility** shortcut on the desktop.
3. Click the **“Search Servers”** button to search your tGW-700/GW-2200.
4. Once the search process is complete, double-click on the module name to open the **“Configure Server”** dialog box.

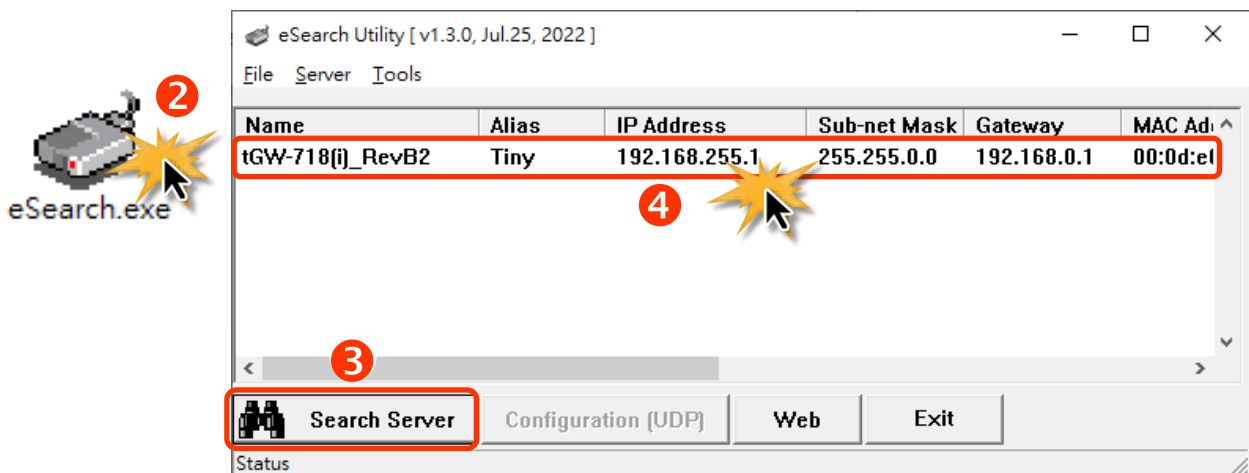

Factory Default Settings of tGW-700/GW-2200 Series Module:

IPv4 settings		Writable
IP Address	192.168.255.1	✓
Subnet Mask	255.255.0.0	✓
Gateway	192.168.0.1	✓
IPv6 settings		Writable
User-defined	fc00::1	✓
Link-Local	EUI-64 format	✗
SLAAC	Auto-Configure	✗

5. Enter the network settings information, including the **IP, Mask, Gateway addresses**, and then click **“OK”** button. The new settings for the tGW-700/GW-2200 will take effect within 2 seconds. If you don't know the correct network configuration information, contact your Network Administrator to obtain the details.

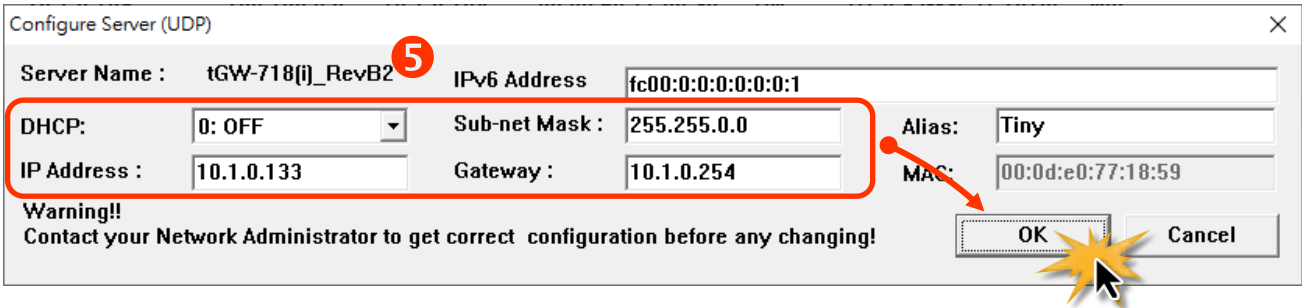

Note: The DHCP feature is only valid on IPv4.

6. Wait 2 seconds and click **“Search Servers”** button again to ensure the tGW-700/GW-2200 is working well with new configuration.

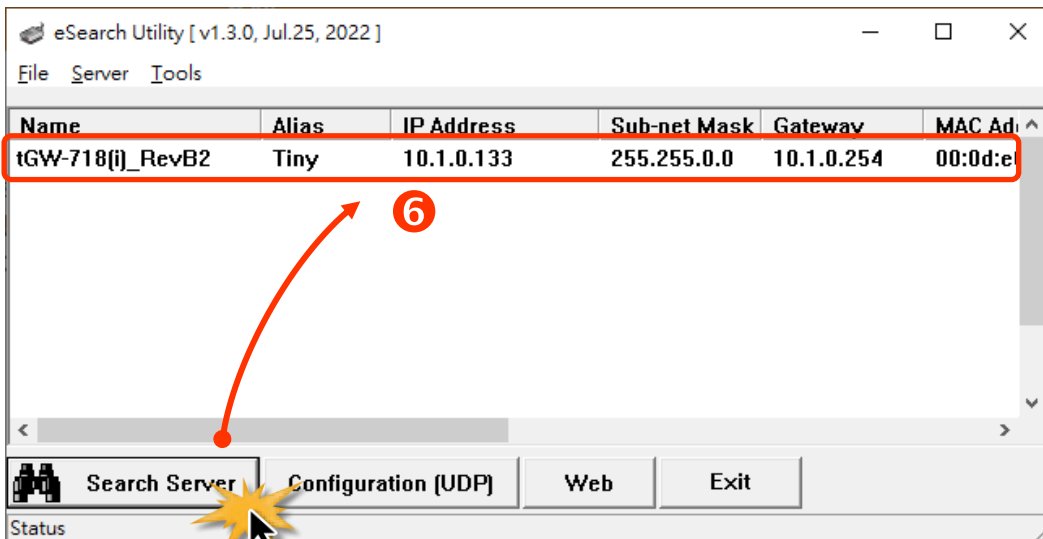

3.3 Connecting the Modbus Devices

Note: The wiring and supply power method vary depending on your Modbus device. Here, the M-7022 module is used as an example. For other Modbus device or third party Modbus device, refer to the product user manual for relevant information.

Connect the tGW-700/GW-2200 with Modbus device (e.g., M-7022, optional) and supply power (+10 to +30 VDC) to the Modbus device. For more detailed information related to wiring options for RS-232/422/485, refer to [Section 2.5 “Wiring Notes for RS-232/485/422 Interfaces”](#).

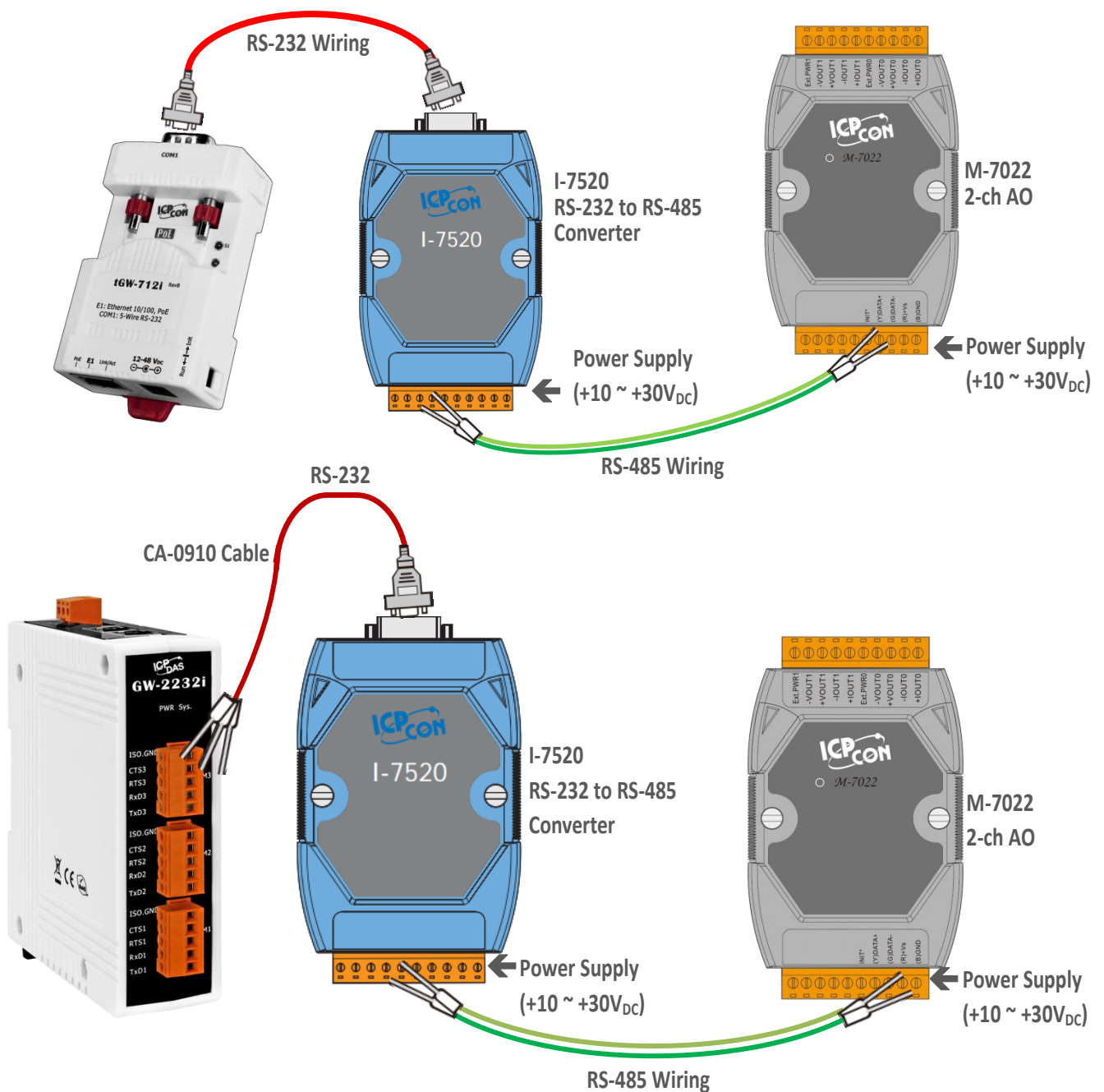

3.4 Configuring the Serial Port

1. Open a web browser, such as Google Chrome, Microsoft Edge or Apple Safari, enter the IP address of the tGW-700/GW-2200 module in the address bar and then click “**Enter**”, or click the “**Web**” button in the eSearch Utility.
2. To enhance the security, you are prompted to change the password when you login to the module for the first time. Enter the default password: **admin** in the **Current password** field, and enter your new password in the **New password** and **Confirm new password** fields, then click the “**Submit**” button.

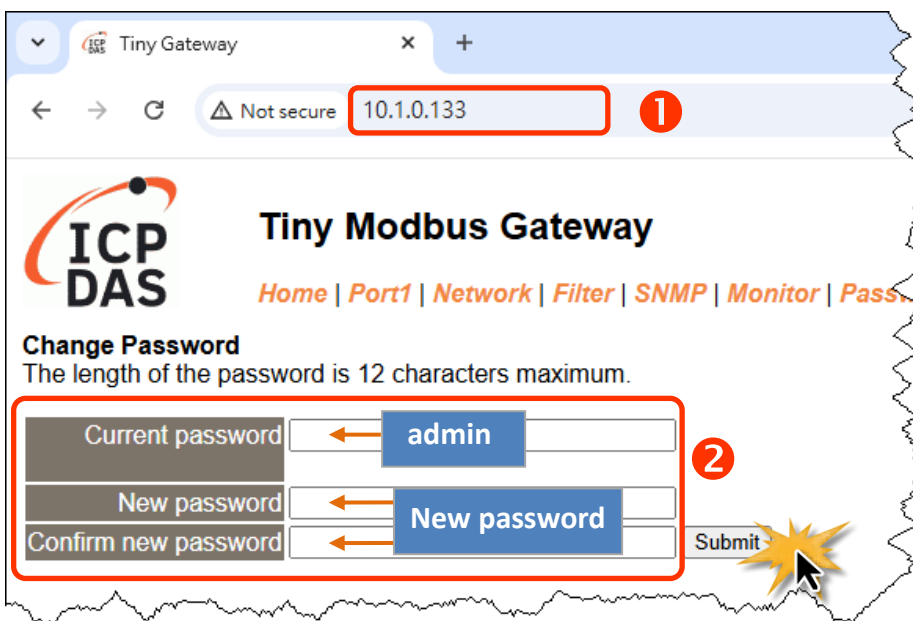

3. Enter the new password in the **Login password** field, and then click the “**Submit**” button to enter the configuration web page.

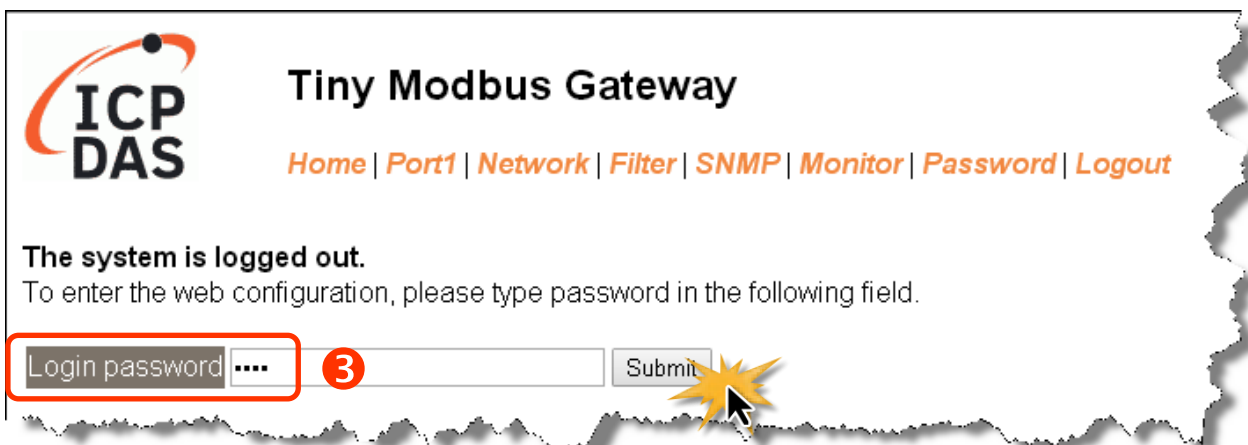

4. Click the **“Port1”** tab to display the Port1 Settings page.

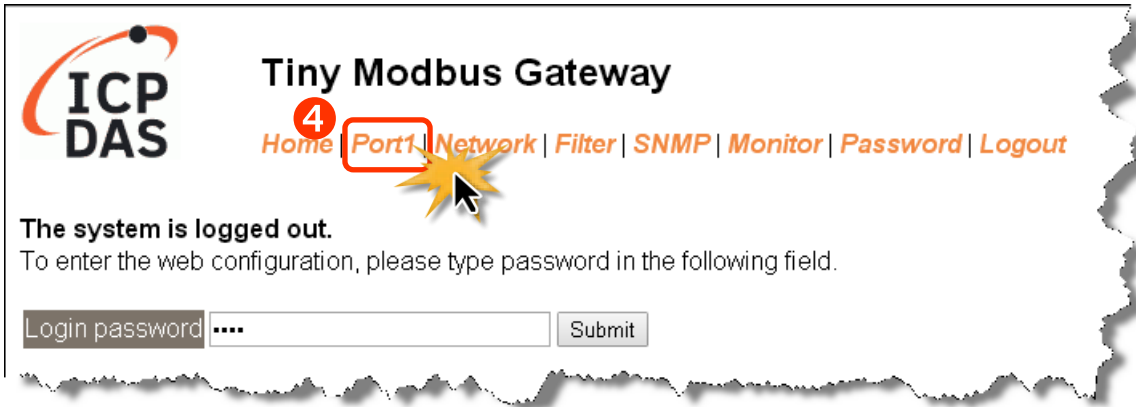

5. **tGW-718i-D:** Select RS-232 or RS-422/485 in the **“Interface”** drop down list depending on your external device type.
Others: The interface is depending on your tGW-700/GW-2200 models and wirings, no interface setting on the web page.

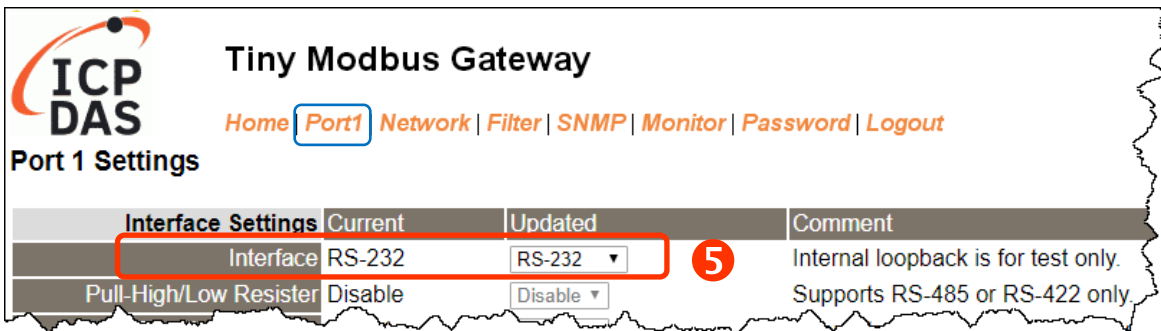

- Select the appropriate Baud Rate, Data Format and Modbus Protocol (e.g., 19200, 8N2 and Modbus RTU) from the relevant drop down options.

Notes:

- The Baud Rate, Data Format and Modbus protocol settings depends on your Modbus device.
- Only one protocol can be used for each serial port.

- Click **“Submit”** to save your settings.

Tiny Modbus Gateway
[Home](#) [Port1](#) [Network](#) | [Filter](#) | [SNMP](#) | [Monitor](#) | [Password](#) | [Logout](#)

Port 1 Settings

Port Settings	Current	Updated	Comment
Baud Rate	115200	19200 (select)	bps (bits/second)
Data Size	8	8	bits/char
Parity	None	None	
Stop Bits	1	2	
Flow Control	None	None	
Remove Errors	FE BE	<input type="checkbox"/> Parity Error <input checked="" type="checkbox"/> Framing Error <input checked="" type="checkbox"/> Break Error	Clear RX FIFO data when serial errors.

Modbus Settings

Modbus Settings	Current	Updated	Comment
Slave Timeout	300	300	10 - 65000 ms (step 10), Default: 300. (Note)
Char Timeout	4	4	4 - 15 bytes, Default: 4
Silent Time	0	0	0 - 65000 ms (step 10), Default: 0
Protocol	Modbus RTU	Modbus RTU	
Virtual ID Range	0 - 247	0 to 247	Range: 0 to 247. Note: Gateway skips the Modbus messages if its ID is NOT in the specified range.
Virtual ID Offset	0	0	Offset: -246 to 246, No change=0. For example: Virtual ID = 1 to 10, offset = 10, then physical Slave ID = 11 to 20. Virtual ID = 31 to 40, offset = -10, then physical Slave ID = 21 to 30.

Modbus TCP Settings

Modbus TCP Settings	Current	Updated	Comment
Queue Timeout	1000	1000	100 - 65000 (step 10), Default: 1000. (Note)

Action Settings (Master/Slave Mode)

Action Settings (Master/Slave Mode)	Current	Updated	Comment
Application Mode	Server	Server	Server: Modbus TCP/UDP master to Modbus RTU/ASCII slave Client: Modbus RTU/ASCII master to Modbus TCP/UDP slave

Submit

3.5 Self-Test

1. In the eSearch Utility, select the **“Modbus TCP Master”** item from the **“Tools”** menu to open the Modbus TCP Master Utility.

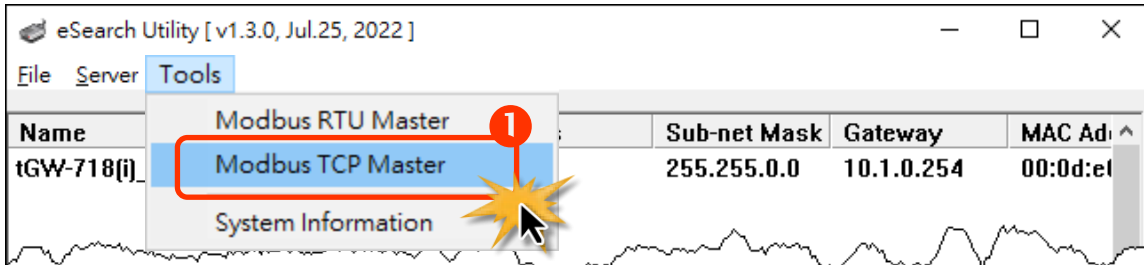

2. In the Modbus TCP Master Utility, enter the **IP address of tGW-700/GW-2200** in the **“Modbus TCP”** section, and then click the **“Connect”** button to connect to the tGW-700/GW-2200.
3. Refer to **“Protocol Description”** section and type the Modbus command in the **“Command”** field then click the **“Send command”** button.
4. If the response data is correct, it means the test is success.

Note: The Modbus command settings depend on your Modbus device.

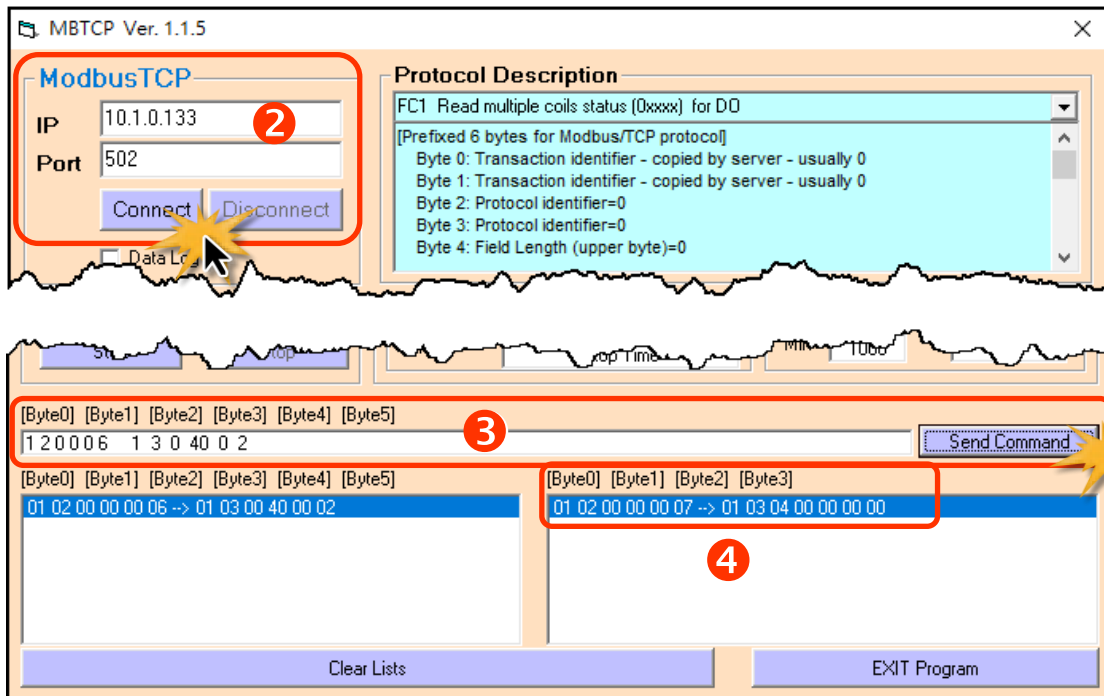

4. Getting Started for tGW-700 / GW-2200 series on IPv6

This chapter provides detailed information about the “Self-Test” process, which is used to confirm that the tGW-700/GW-2200 series module is operating correctly. Before beginning the “Self-Test” process, the wiring test, Ethernet configuration and eSearch/Modbus utility driver installation procedures must first be fully completed. Follow the procedure described below:

Note: This chapter is based on IPv6 environment.

4.1 Connecting the Power and Host PC

1. Ensure that the network settings on your PC are configured correctly.
Ensure that the Windows firewall or any Anti-Virus firewall software is correctly configured or temporarily disable these functions; otherwise the “**Search Servers**” function in the eSearch Utility may not work as required. You may need to contact your System Administrator for more details of how to do this.

2. Check that the **Init/Run switch** is in the “**Run**” position.

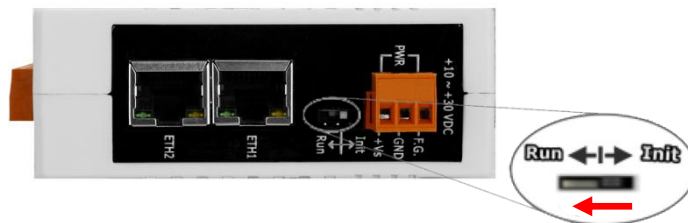
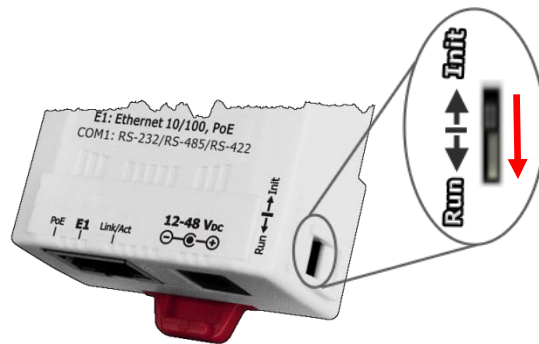

3. Connect both the tGW-700/GW-2200 and the Host computer to the same sub-network or the same Ethernet Switch, and then supply power (PoE or +12 to +48 Vdc) to the tGW-700/GW-2200.

PoE Power Supply

Note: tGW-700-T series don't support PoE.

tGW-700 Series

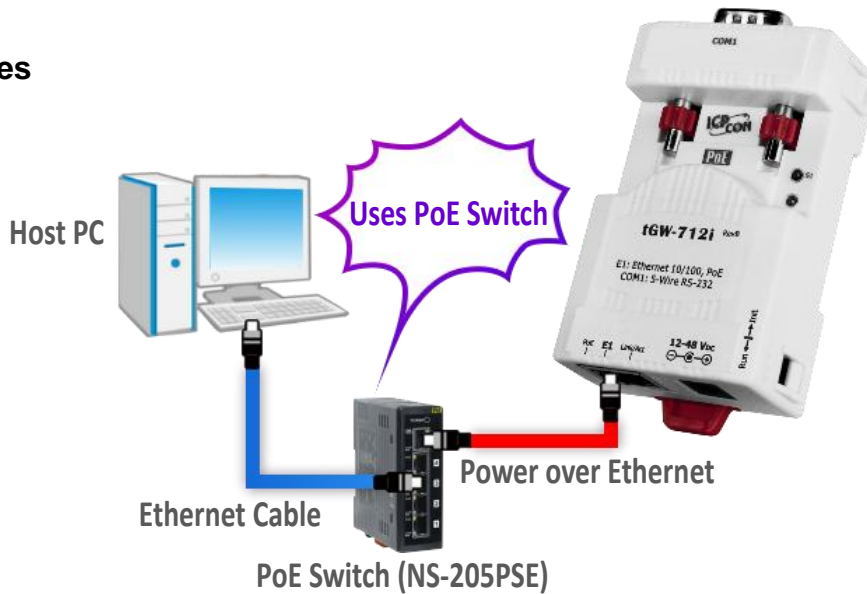

GW-2200 Series

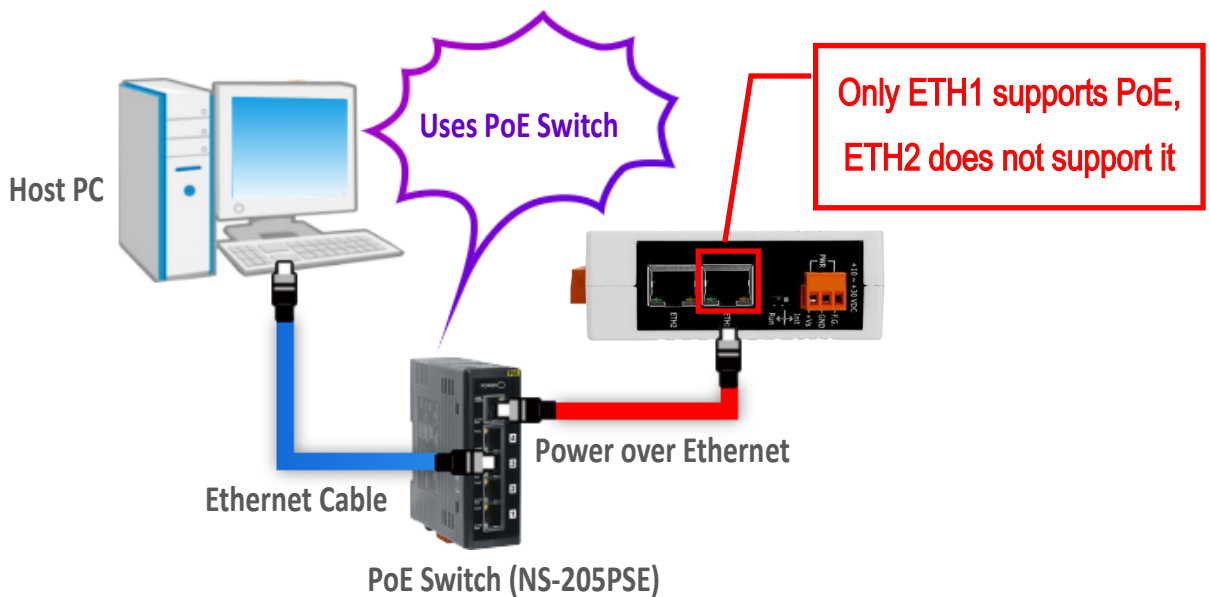

+12 to +48 VDC Jack Power Supply (Non-PoE)

tGW-700 Series

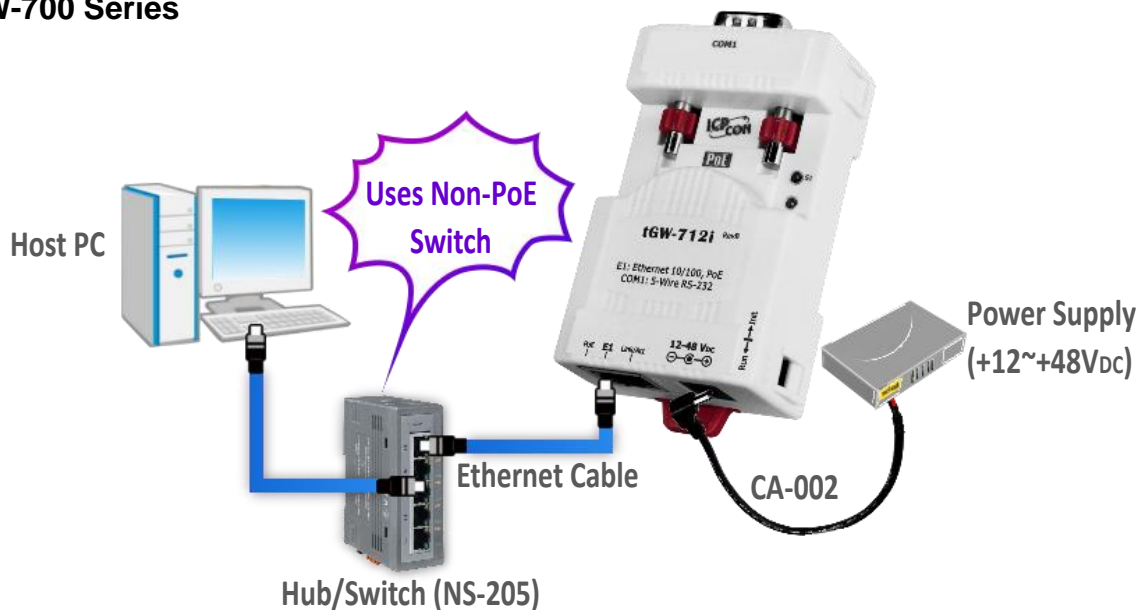

tGW-700-T Series

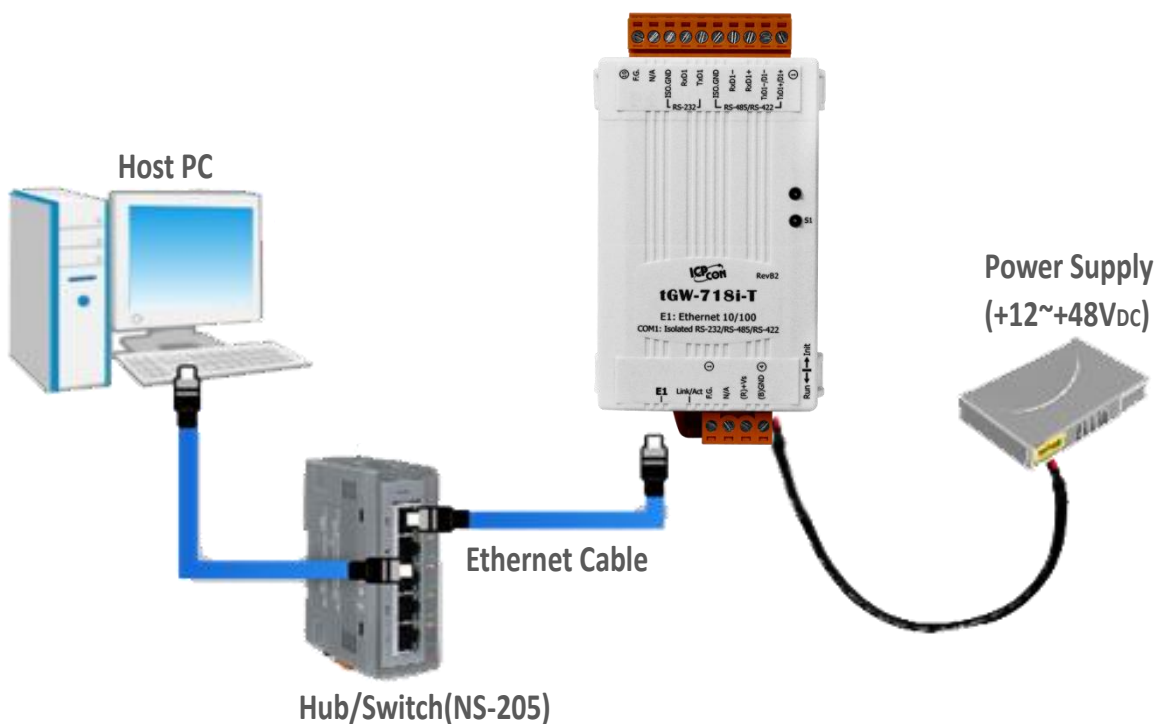

GW-2200 Series

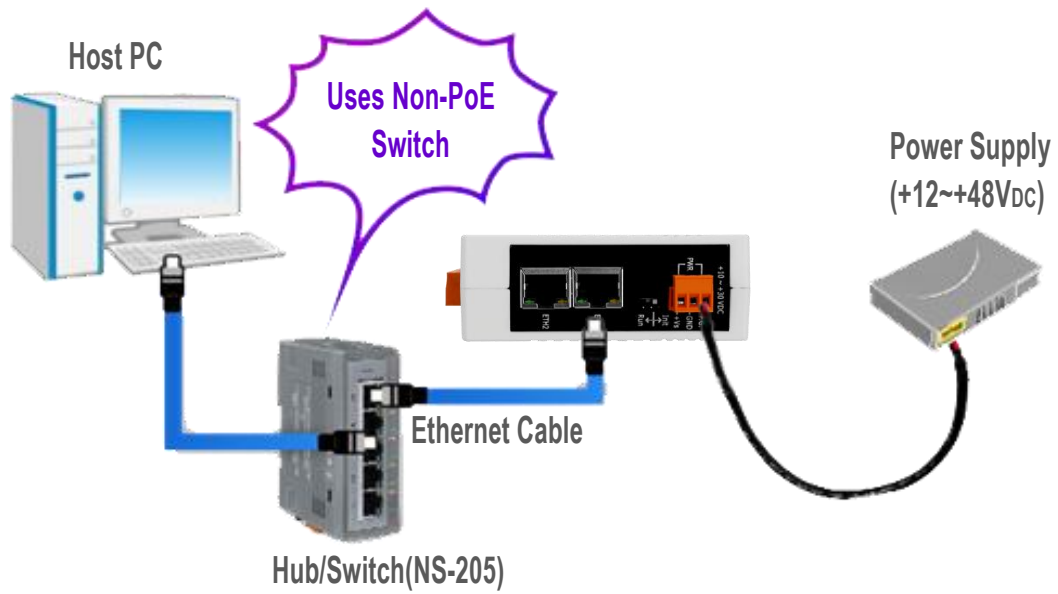

4. Verify that the System (S1) LED indicator is flashing.

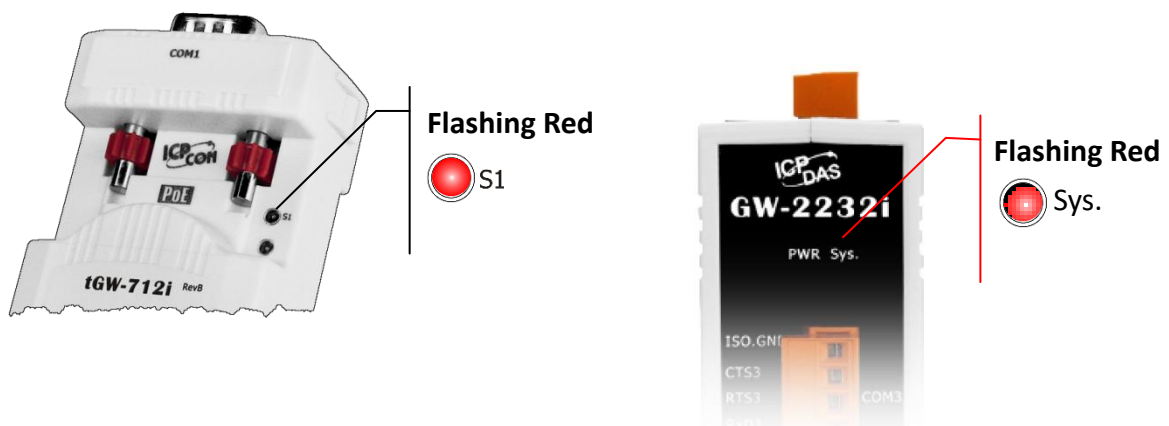

4.2 Configuring Network Settings

1. Download the **eSearch Utility** and install it according to the installation instructions.



The eSearch Utility can be obtained from the link below:

 https://www.icpdas.com/en/product/guide+Software+Utility_Driver+eSearch_Utility

Note: eSearch Utility version v1.2.5 or later is required for the following configuration.

2. Double click the **eSearch Utility** shortcut on the desktop.
3. Click the **“Search Servers”** button to search your tGW-700/GW-2200.

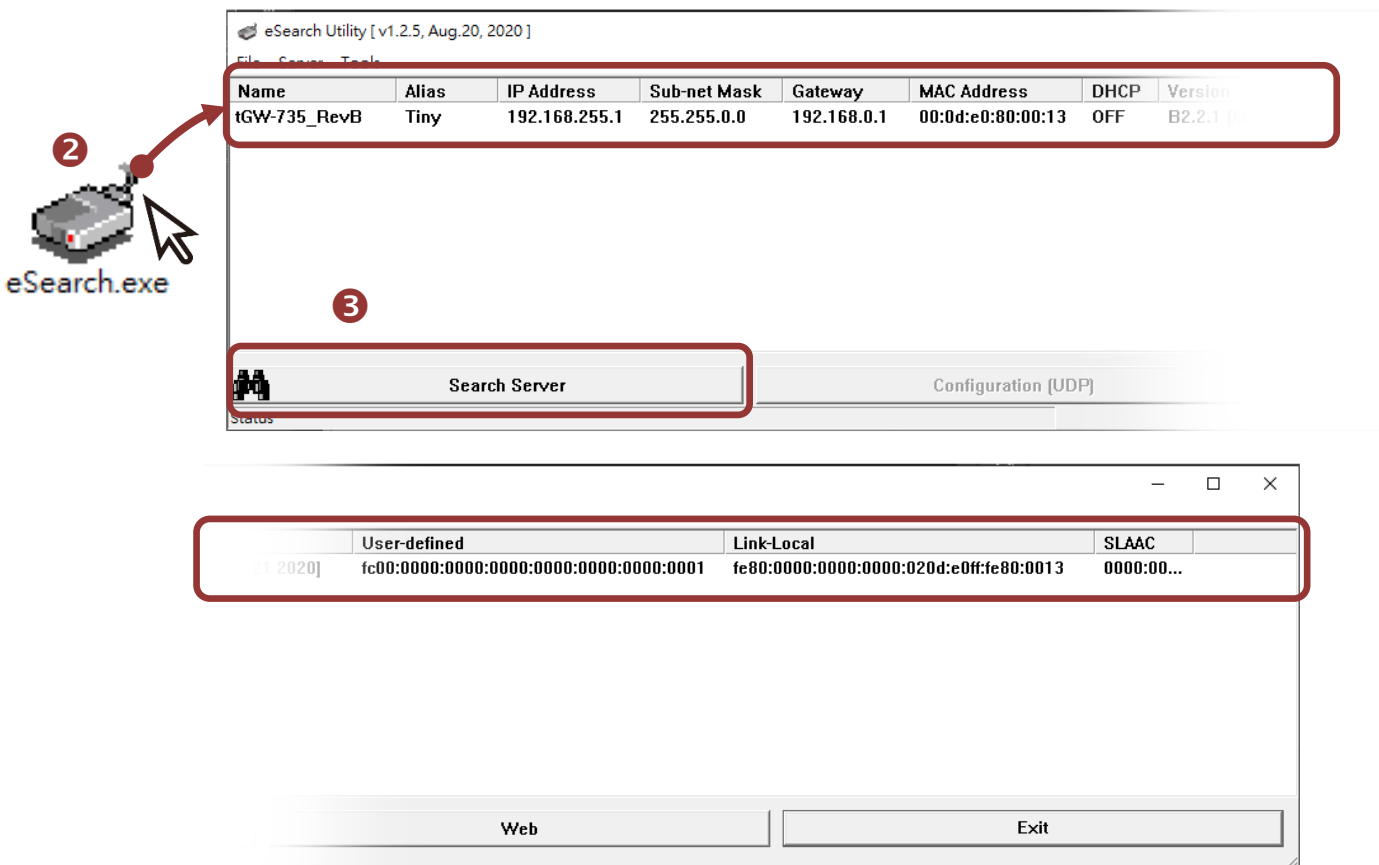

- Every IPv6 device has the Link-Local address. You can view the Link-Local address of the tGW-700/GW-2200 module in the “Link-Local” field without configuring. If your environment supports Stateless Address Auto-configuration (SLAAC), the SLAAC field will display the SLAAC address when the SLAAC configuration is completed. You can click the “**Search Servers**” button again to update the state.

Factory Default Settings of tGW-700/GW-2200 Series Module:

IPv4 settings		Writable
IP Address	192.168.255.1	✓
Subnet Mask	255.255.0.0	✓
Gateway	192.168.0.1	✓
IPv6 settings		Writable
User-defined	fc00::1	✓
Link-Local	EUI-64 format	✗
SLAAC	Auto-Configure	✗

4.3 Connecting the Modbus Devices

Note: The wiring and supply power method vary depending on your Modbus device. Here, the M-7022 module is used as an example. For other Modbus device or third party Modbus device, refer to the product user manual for relevant information.

Connect the tGW-700/GW-2200 with Modbus device (e.g., M-7022, optional) and supply power (+10 to +30 VDC) to the Modbus device. For more detailed information related to wiring options for RS-232/422/485, refer to [Section 2.5 “Wiring Notes for RS-232/485/422 Interfaces”](#).

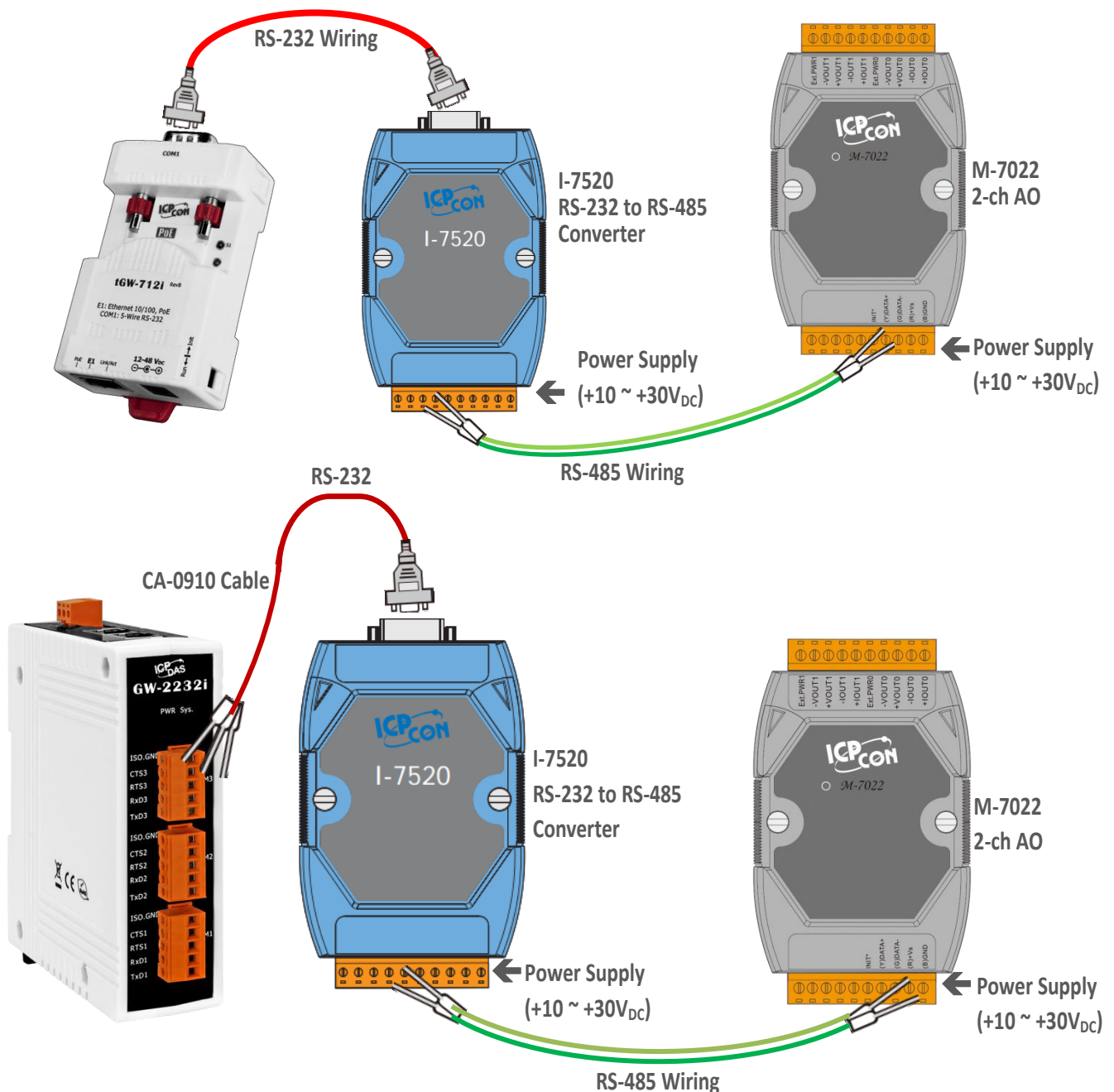

4.4 Configuring the Serial Port

1. Right Click on the Link-Local field and click the **“Copy to Clipboard”** to copy the **“Link-Local address”** of the tGW-700/GW-2200 module.
2. Paste the **“Link-Local address”** of the tGW-700/GW-2200 module in the address bar of the browser and add the brackets, i.e., **[Link-Local address]**.

Note: The Web button use the IPv4 address to access the Web Server, not IPv6 address.

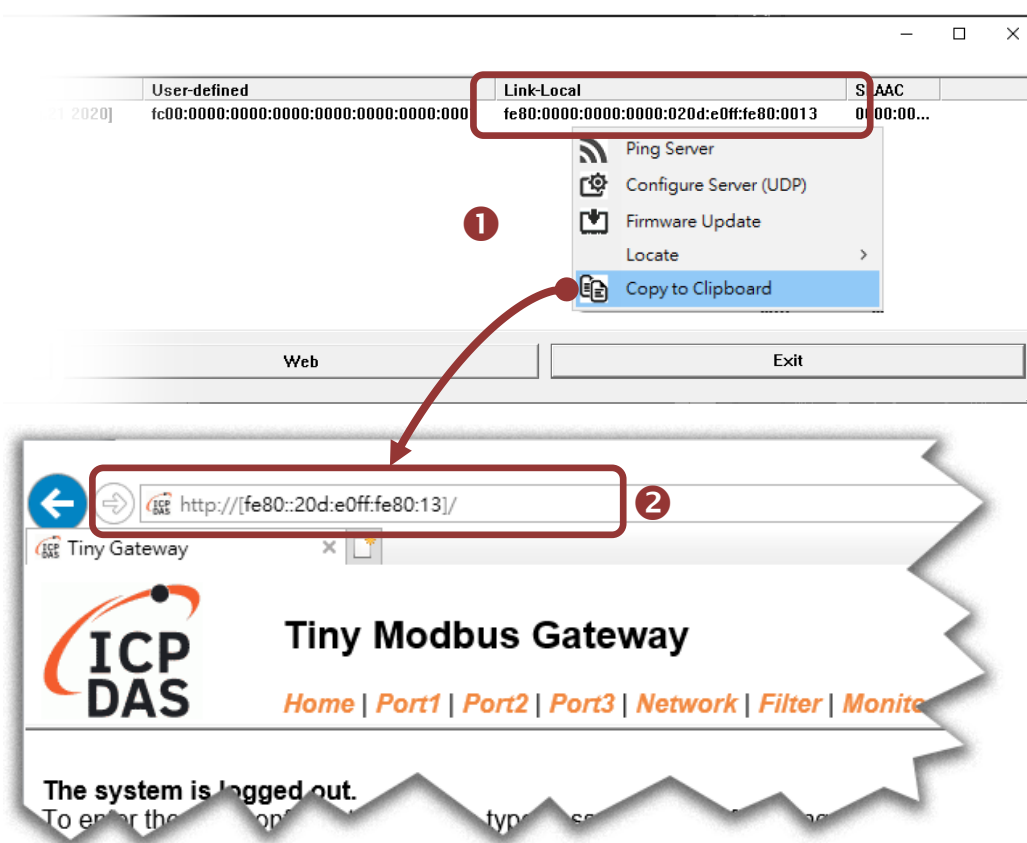

- To enhance the security, you are prompted to change the password when you login to the module for the first time. Enter the default password: **admin** in the **Current password** field, and enter your new password in the **New password** and **Confirm new password** fields, then click the **“Submit”** button.

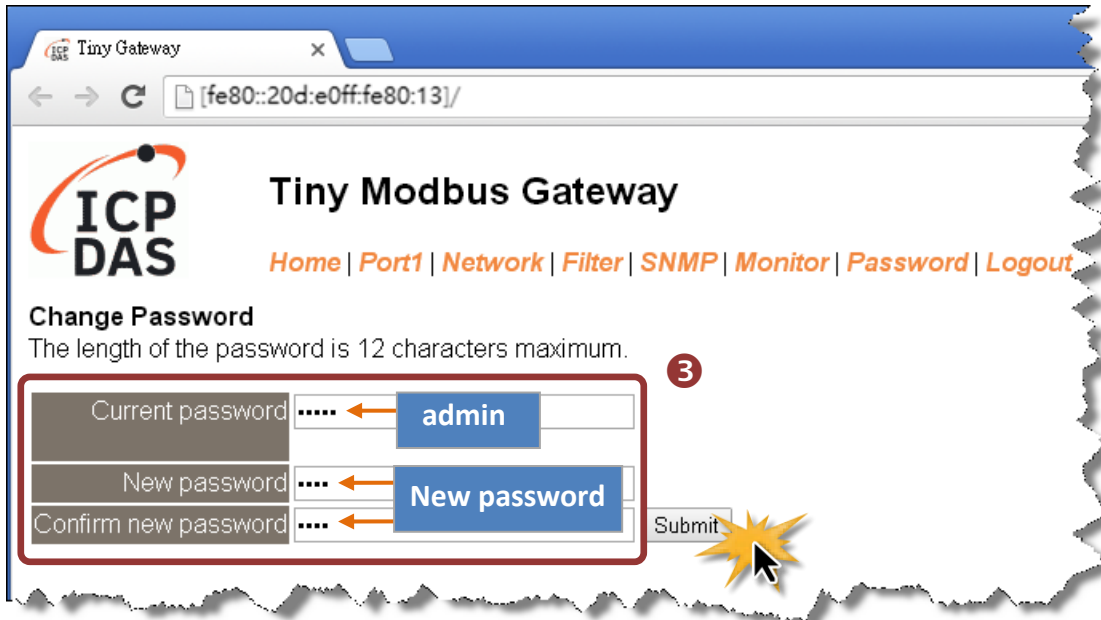

- Enter the new password in the **Login password** field, and then click the **“Submit”** button to enter the configuration web page.

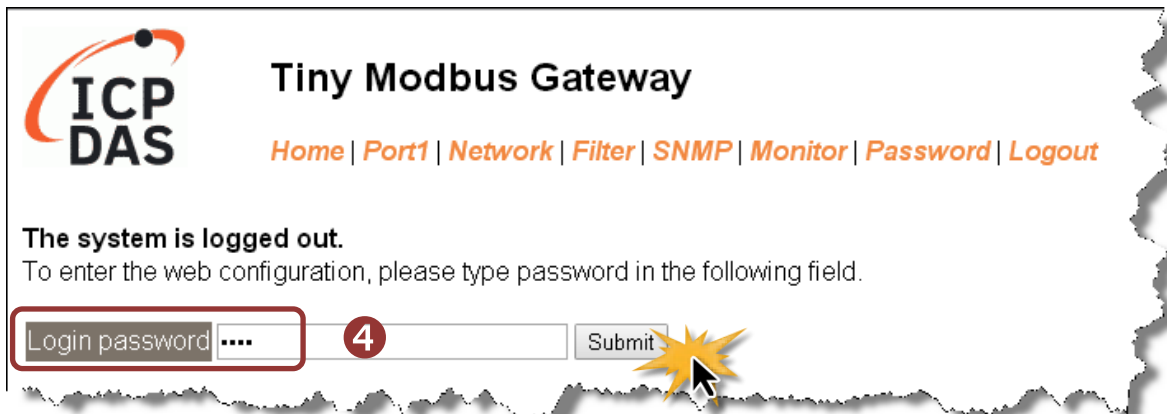

- 5. Click the “Port1” tab to display the Port1 Settings page.



- 6. **tGW-718i-D:** Select RS-232 or RS-422/485 in the “Interface” drop down list depending on your external device type.
Others: The interface is depending on your tGW-700/GW-2200 models and wirings, no interface setting on the web page.

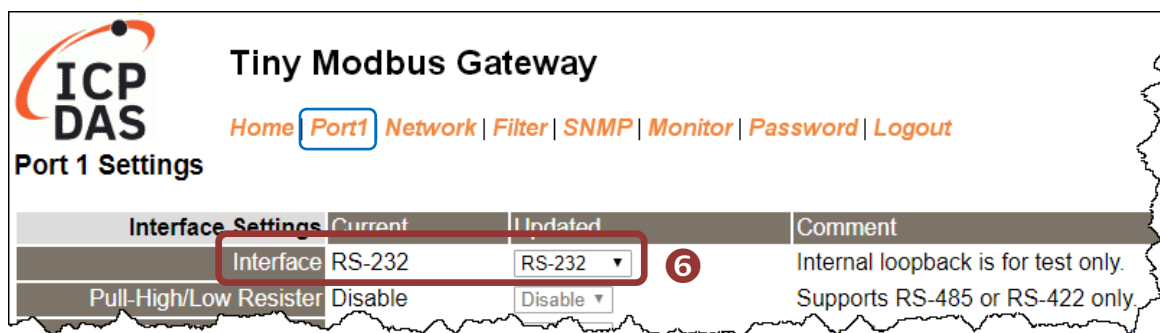

7. Select the appropriate Baud Rate, Data Format and Modbus Protocol (e.g., 19200, 8N2 and Modbus RTU) from the relevant drop down options.

Notes:

1. The Baud Rate, Data Format and Modbus protocol settings depends on your Modbus device.
2. Only one protocol can be used for each serial port.

Tiny Modbus Gateway
[Home](#) [Port1](#) [Network](#) | [Filter](#) | [SNMP](#) | [Monitor](#) | [Password](#) | [Logout](#)

Port 1 Settings

Port Settings	Current	Updated	Comment
Baud Rate	115200	19200 (select <input type="text" value="19200"/>)	bps (bits/second)
Data Size	8	8	bits/char
Parity	None	None	
Stop Bits	1	2	
Flow Control	None	None	
Remove Errors	FE BE	<input type="checkbox"/> Parity Error <input checked="" type="checkbox"/> Framing Error <input checked="" type="checkbox"/> Break Error	Clear RX FIFO data when serial errors.
Modbus Settings	Current	Updated	Comment
Slave Timeout	300	300	10 - 65000 ms (step 10), Default: 300. (Note)
Char Timeout	4	4	4 - 15 bytes, Default: 4
Silent Time	0	0	0 - 65000 ms (step 10) Default: 0
Protocol	Modbus RTU	Modbus RTU	
Virtual ID Range	0 - 247	0 to 247	Range: 0 to 247. Note: Gateway skips the Modbus messages if its ID is NOT in the specified range.
Virtual ID Offset	0	0	Offset: -246 to 246, No change=0. For example: Virtual ID = 1 to 10, offset = 10, then physical Slave ID = 11 to 20. Virtual ID = 31 to 40, offset = -10, then physical Slave ID = 21 to 30.
Modbus TCP Settings	Current	Updated	Comment
Queue Timeout	1000	1000	1000 - 65000 (step 10) Default: 1000 (Note)

8. Click “Submit” to save your settings.

Application Mode (Master/Slave Mode)

Application Mode	Current	Updated	Comment
Application Mode	Server	Server	Server: Modbus TCP/UDP master to Modbus RTU/ASCII slave Client: Modbus RTU/ASCII master to Modbus TCP/UDP slave

4.5 Self-Test

1. Download and install the “Modbus Poll” test program at below link.

<https://www.modbustools.com/download.html>

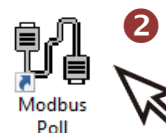

2. Double-click the Modbus Poll shortcut to open.
3. Select the “Read/Write Definition...” item from the “Setup” menu to open the “Read/Write Definition” dialog box.
4. Configure the settings for the Slave.

Note: The Modbus Slave settings depends on your Modbus device.

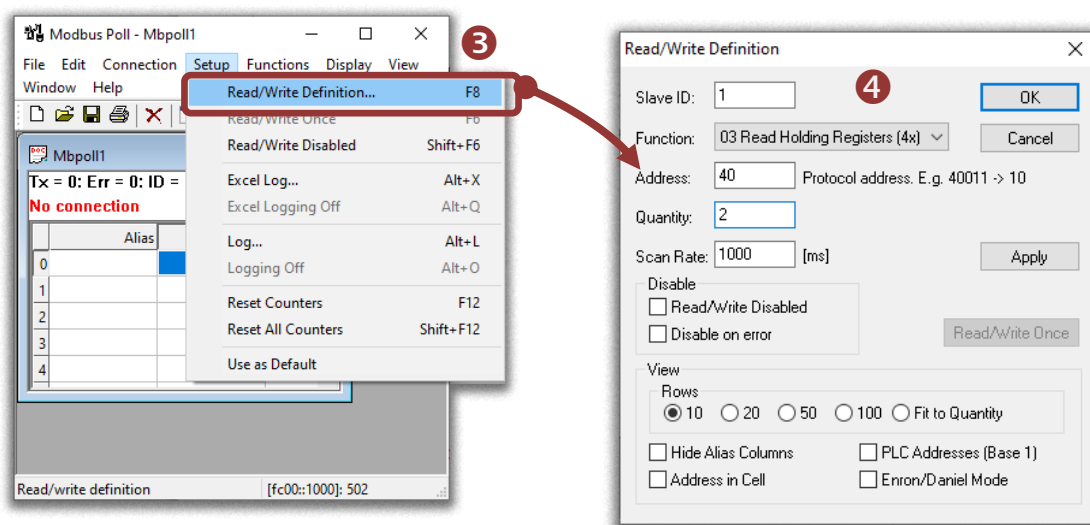

5. Select the “Connect...” item from the “Connection” menu to open the “Connection Setup” dialog box.
6. Configure the IPv6 address and TCP port (default: 502) of tGW-700/GW-2200 and click “OK” to connect the tGW-700/GW-2200 for testing.

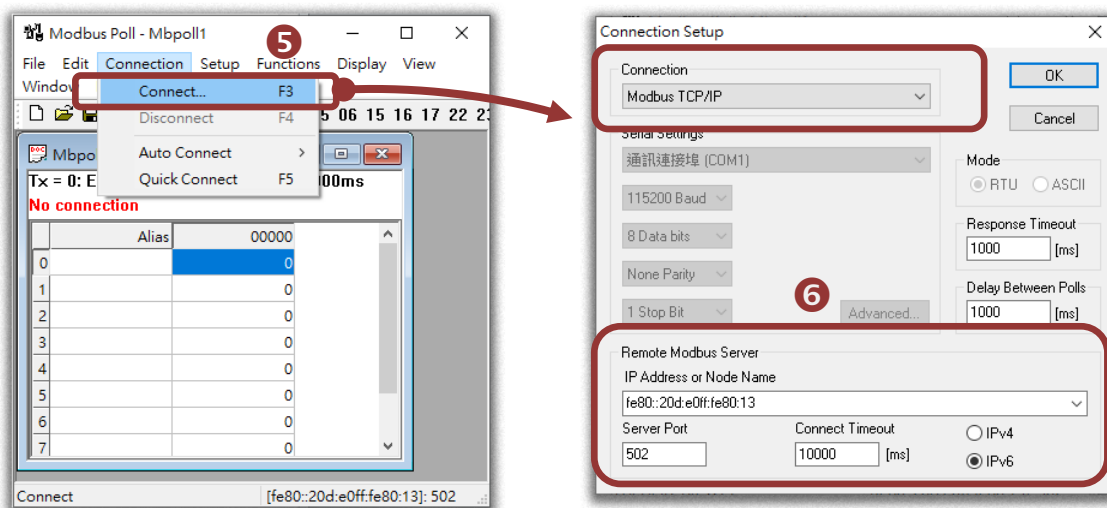

7. If the response data is correct, it means the test is success.

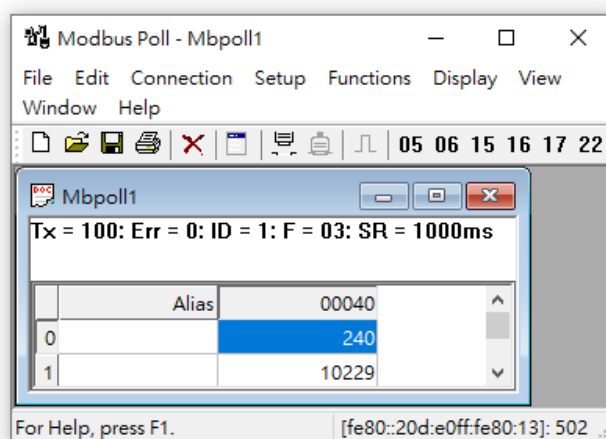

5. Web Configuration

Once the tGW-700/GW-2200 series module has been correctly configured and is functioning normally on the network, the configuration details can be retrieved or modified using either the eSearch Utility described above, or via a standard web browser.

5.1 Logging in to the tGW-700/GW-2200 Web Server

The embedded tGW-700/GW-2200 series web server can be accessed from any computer that has an Internet connection.

Step 1: Open a new browser window

Open a web browser, for example, Google Chrome, Microsoft Edge or Apple Safari, which are reliable and popular browsers that can be used to configure tGW-700/GW-2200 series module.

Step 2: Enter the URL for the tGW-700/GW-2200 web server

Ensure that you have correctly configured the network settings for the tGW-700/GW-2200 series module (refer to [Chapter 3 “Getting Started for tGW-700/GW-2200 series using IPv4”](#), [Chapter 4 “Getting Started for tGW-700/GW-2200 series using IPv6”](#) for detailed instructions), and then enter the URL for the tGW-700/GW-2200 web server in the address bar of the browser.

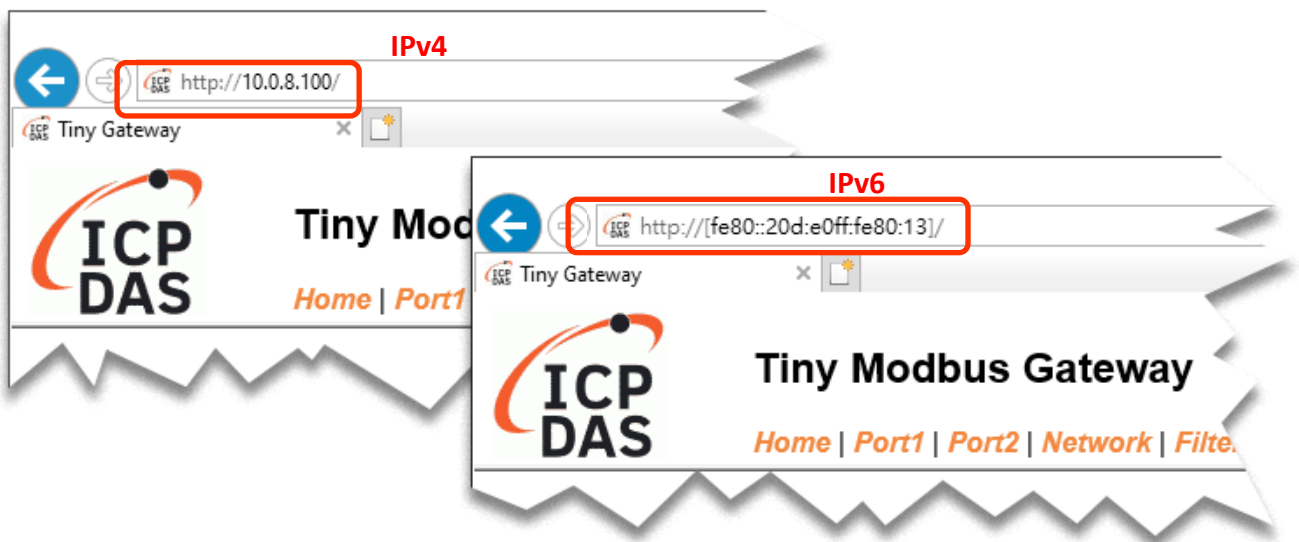

Step 3: Enter the Password

After connecting to the IP address, the login page is displayed. Enter your password in the **Login password** field, and then click the “**Submit**” button to continue. (If this is the first time you login, refer to [Section 3.4](#) to change the factory default password.)

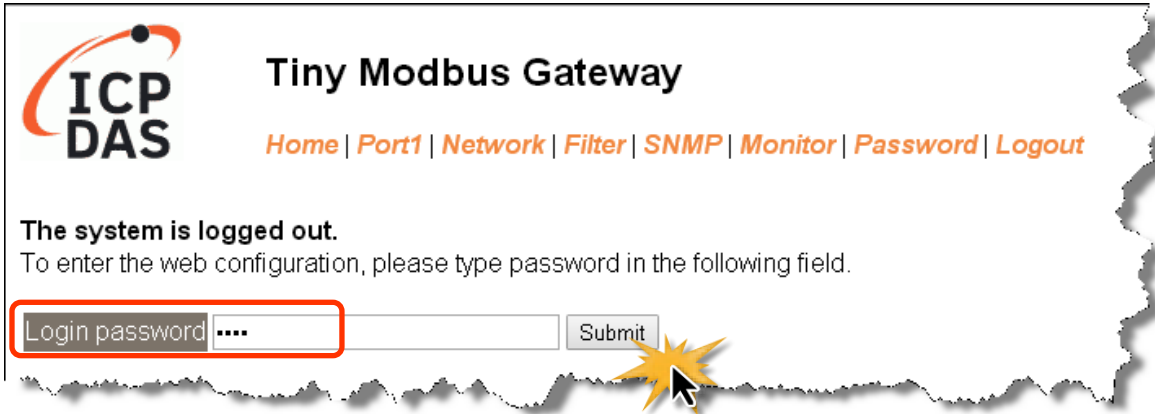

Step 4: Log in to the tGW-700/GW-2200 Web Server

After login, the first page displayed is the “Home” page.

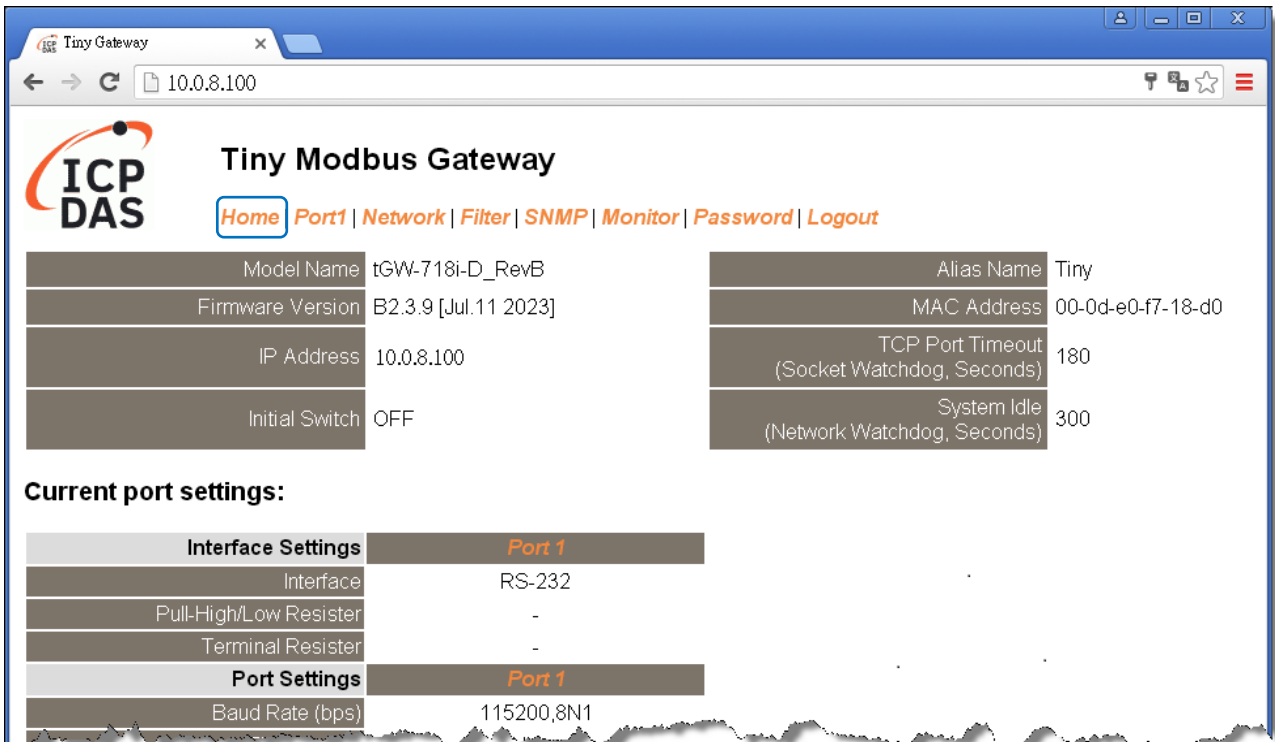

5.2 Home Page

The **Home** link connects to the main page, which contains two parts.



The first part of this page provides basic information about the tGW-700/GW-2200 hardware and software. The software and hardware information section includes information related to the Model Name, the current Firmware version, the IP Address, the current position of the Initial Switch, the Alias, the MAC Address, and the TCP Port, and the System Timeout values. **If the firmware for the tGW-700/GW-2200 module is updated, you can check the version information here.**

Model Name	tGW-718(i)_RevB2	Alias Name	Tiny
Firmware Version	B2.4.2 [Jan.04 2024]	MAC Address	00-0d-e0-77-18-59
IP Address	10.1.0.100	TCP Port Timeout (Socket Watchdog, Seconds)	180
Initial Switch	OFF	System Idle (Network Watchdog, Seconds)	300

The lower section provides information related to the port settings and pair-connection settings.

Current port settings: Only tGW-718i-D has this field.

Interface Settings		<i>Port 1</i>
Interface		RS-232
Pull-High/Low Resister		-
Terminal Resister		-
Port Settings		<i>Port 1</i>
Baud Rate (bps)		115200,8N1
Flow Control		None
Protocol		RTU
Slave Timeout (ms)		300
Char Timeout (bytes)		4
Silent Time (ms)		0
Read Cache (ms)		980
Connection Idle (Seconds)		180
Local TCP Port		502
Virtual ID Range		0-247
Virtual ID Offset		0
Pair-Connection Settings (Master/Slave Mode)		Port 1
Application Mode		TCP/UDP Server

5.3 Network Page

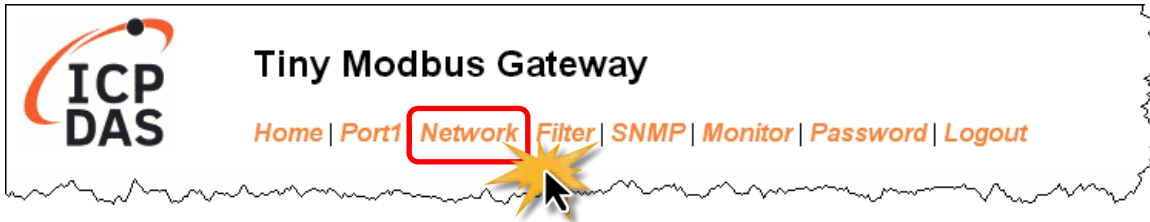

Click **Network** in the navigation toolbar to view the page, which allows you to verify the current settings, configure the IP Address, and the general parameters, and restore the default settings for the tGW-700/GW-2200 module, each of which will be described in more detail below.

5.3.1 IP Address Selection

The **Address Type**, **Static IPv4 Address**, **Subnet Mask** and **Default Gateway** values are the most important network settings and should always correspond to the LAN configuration. If they do not match, the tGW-700/GW-2200 module will not operate correctly in IPv4.

The **IPv6 Link Local Address** always valid within the same link layer. The **IPv6 SLAAC Address** is automatically configured by the router, with the router’s link-local address serving as the default router. An **IPv6 User-defined Address** can also be manually configured. This option is typically more convenient for simple applications. The **IPv6 User-defined Address** can be routed if its prefix matches that of the **IPv6 SLAAC Address**.

Please note that if the settings are changed while the module is in operation, any active connections will be terminated and errors may occur. If the operating environment does not support IPv6, the IPv6 Address fields can be disregarded.

IPv4 Address		
Address Type	Static IP ▾	
Static IPv4 Address	10 . 1 . 0 . 100	
Subnet Mask	255 . 255 . 0 . 0	
Default Gateway	10 . 1 . 0 . 254	
MAC Address	00-0d-e0-77-18-59	(Format: FF-FF-FF-FF-FF-FF)
IPv6 Address		
Link Local Address	fe80:0:0:0:20d:e0ff:fe77:1859	
SLAAC Address	0:0:0:0:0:0:0:0	
SLAAC Timeout	0	(30 ~ 65000 seconds, 0 = Default Disabled)
User-defined Address	fc00:0:0:0:0:0:0:1	
DNS Settings	Client Mode Only	
Auto DNS Configuration	Enable ▾ (Auto DNS Server Configuration by IPv4 DHCP, default enabled.)	
Preferred DNS Server IP	208.67.222.222	IPv4 example: 208.67.222.222 , IPv6 example: 2620:119:35::35
Alternate DNS Server IP	208.67.220.220	IPv4 example: 208.67.220.220 , IPv6 example: 2620:119:53::53
Update Settings		

The following is an overview of the parameters contained in the **IP Address Selection** section:

Item	Description
IPv4: Address Type	<p>Static IP: If no DHCP server is installed on the network, the network settings can be configured manually. Refer to Section “Manual Configuration” for more details.</p>
	<p>DHCP: The Dynamic Host Configuration Protocol (DHCP) is a network application protocol that automatically assigns an IPv4 address to each device. Refer to Section “Dynamic Configuration” for more details.</p> <p>Note: The DHCP function doesn't effective on IPv6.</p>
IPv4: Static IPv4 Address	<p>Each tGW-700/GW-2200 connected to the network must have its own unique IP address. This parameter is used to assign a specific IPv4 address.</p>
IPv4: Subnet Mask	<p>Assigns the subnet mask for the tGW-700/GW-2200. The subnet mask indicates which portion of the IPv4 address is used to identify the local network or subnet.</p>
IPv4: Default Gateway	<p>Assigns the IPv4 Address of the Gateway to be used by the tGW-700/GW-2200. A Gateway (or router) is a device that is used to connect an individual network to one or more additional networks.</p>
IPv4: MAC Address	<p>Sets a user-defined MAC address, which must be in the format FF-FF-FF-FF-FF-FF.</p>
IPv6: Link Local Address	<p>Each IPv6 device connected to the network must have a link-local address. It always effective in the same link layer. It is auto-configured by EUI-64. If your environment doesn't support the IPv6, please ignore this field.</p>
IPv6: SLAAC Address	<p>The tGW-700/GW-2200 supports stateless address auto configuration (SLAAC). It will be configured by the Router automatically, and the default router is the link-local address of the router. The router should provide the prefix and the tGW-700 will calculate the Host ID by EUI-64. If your environment doesn't support the SLAAC, please ignore this field.</p>
IPv6: SLAAC Timeout (SLAAC Watchdog)	<p>Configures the SLAAC timeout value. If the SLAAC address doesn't be configured in the specified time, the system will be rebooted to configure the SLAAC address again. Timeout value range: 30 to 65535 (seconds); Disable = 0;</p>
IPv6: User-defined Address	<p>It can be defined by the User. It's more convenient than using the link-local address in the simple application. This address can be routed if the prefix as same as IPv6 SLAAC Address. If your environment doesn't support the IPv6, please ignore this field.</p>
Update Settings	<p>Clicks this button to save the revised settings to the tGW-700/GW-2200.</p>

Manual Configuration

When using manual configuration, the network settings should be assigned in the following manner:

Step 1: Select the “Static IP” option from the “Address Type” drop-down menu.

Step 2: Enter the relevant details in the respective **network settings** fields. If your environment doesn’t support the IPv6, please ignore the “IPv6 User-defined Address” fields.

Step 3: Click the “Update Settings” button to complete the configuration.

IP Address

IPv4 Address	
Address Type	Static IP 1
Static IPv4 Address	192 . 168 . 255 . 1
Subnet Mask	255 . 255 . 0 . 0 2
Default Gateway	192 . 168 . 0 . 1
MAC Address	00-0d-e0-77-18-59 (Format: FF-FF-FF-FF-FF-FF)
IPv6 Address	
Link Local Address	fe80:0:0:0:20d:e0ff:fe77:1859
SLAAC Address	0:0:0:0:0:0:0
SLAAC Timeout	0 (30 ~ 65000 seconds, 0 = Default Disabled)
User-defined Address	fc00:0:0:0:0:0:1 2
DNS Settings Client Mode Only	
Auto DNS Configuration	Enable (Auto DNS Server Configuration by IPv4 DHCP, default enabled.)
Preferred DNS Server IP	208.67.222.222 IPv4 example: 208.67.222.222 , IPv6 example: 2620:119:35::35
Alternate DNS Server IP	208.67.220.220 IPv4 example: 208.67.220.220 , IPv6 example: 2620:119:53::53
<div style="border: 1px solid red; border-radius: 50%; padding: 5px; display: inline-block;">Update Settings</div> 3 	

Note: The IPv6 Link Local Address is auto-configured by EUI-64.

Note: The IPv6 SLAAC Address is auto-configured by Router. The router should provide the prefix and the tGW-700/GW-2200 will calculate the Host ID by EUI-64.

Dynamic Configuration

Dynamic configuration is very easy to perform. If a DHCP server is connected to you network, an IPv4 network address can be dynamically configured by using the following procedure:

Step 1: Select the “DHCP” option from the “Address Type” drop-down menu.

IP Address

IPv4 Address	
Address Type	DHCP 1
Static IPv4 Address	192 . 168 . 255 . 1
Subnet Mask	255 . 255 . 0 . 0
Default Gateway	192 . 168 . 0 . 1
MAC Address	00-0d-e0-77-18-59 (Format: FF-FF-FF-FF-FF-FF)
IPv6 Address	
Link Local Address	fe80:0:0:20d:e0ff:fe77:1859
SLAAC Address	0:0:0:0:0:0
SLAAC Timeout	0 (30 ~ 65000 seconds, 0 = Default Disabled)
User-defined Address	fc00:0:0:0:0:1
DNS Settings	
Client Mode Only	
Auto DNS Configuration	Enable 2 (Auto DNS Server Configuration by IPv4 DHCP, default enabled.)
Preferred DNS Server IP	208.67.222.222 IPv4 example: 208.67.222.222 , IPv6 example: 2620:119:35::35
Alternate DNS Server IP	208.67.220.220 IPv4 example: 208.67.220.220 , IPv6 example: 2620:119:53::53
Update Settings 	

Note: The DHCP is ineffective on IPv6.

Note: The IPv6 Link Local Address is auto-configured by EUI-64.

Note: The IPv6 SLAAC Address is auto-configured by Router. The router should provide the prefix and the tGW-700/GW-2200 will calculate the Host ID by EUI-64.

5.3.2 General Settings

General Settings

Ethernet Speed	Auto <input type="button" value="v"/> (Auto=10/100 Mbps Auto-negotiation)
HTTP port	80 <input type="text"/> (Default= 80)
Alias Name	Tiny <input type="text"/> (Max. 18 chars)
System Timeout (Network Watchdog)	300 <input type="text"/> (30 ~ 65000 seconds, Default: 300, Disable: 0)
Web Auto-logout	10 <input type="text"/> (1 ~ 65000 minutes, Default: 10, Disable: 0)
UDP Heartbeat	0 <input type="text"/> (20 ~ 300 seconds, 0 = Default Disabled)
UDP Configuration	Enable <input type="button" value="v"/> (Enable/Disable the UDP Configuration, Enable=default.)
<input type="button" value="Update Settings"/>	

The following is an overview of the parameters contained in the **General Settings** section:

Item	Description	Default
Ethernet Speed	Sets the Ethernet speed. The default value is Auto (Auto = 10/100 Mbps Auto-negotiation).	Auto
HTTP Port	Defines the HTTP port used by the tGW-700/GW-2200. A module restart is required after changing this setting. Once modified, the new port number must be entered manually in the browser's address bar. The default is 80. For example: if the HTTP port is set to 81, then enter the "IP address: HTTP port" as 10.0.8.123:81 in the browser's address bar.	80
Alias Name	Assigns an alias for each tGW-700/GW-2200 to assist with easy identification.	Tiny
System Timeout (Network Watchdog)	Specifies the system timeout value. If no network activity is detected within the configured time, the system will automatically reboot. Range: 30 to 65000 seconds Disable = 0	300
Web Auto-logout	Defines the inactivity period before the current user is automatically logged out of the web server. Range: 1 to 65000 minutes Disable = 0	10
UDP Heartbeat	Sets the interval at which UDP heartbeat packets are sent. Range: 20 to 300 seconds; Disable = 0	0
UDP Configuration	Enables or disables the UDP configuration function.	Enable
Update Settings	Clicks this button to save the revised settings to the tGW-700/GW-2200.	

5.3.3 Modbus Settings

Modbus Settings

Gateway Net ID	<input type="text" value="255"/> (Default: 255) Note: This is reserved for gateway, NOT for accessing slave devices . Assign an new gateway ID if it is conflict with slave devices.
CRC Exception	<input type="text" value="1"/> (Default: 1) 0: Gateway returns raw data including CRC when CRC error. 1: Gateway reports exception 0x43 when CRC error. 2: Gateway drops packet when CRC error.
Protocol Exception	<input type="checkbox"/> Reports exception 0x41 when slave response is invalid Modbus message.
Timeout Exception	<input type="checkbox"/> Gateway reports exception 0x0B for slave no response, and 0x4B for data timeout.
Busy Exception	<input type="checkbox"/> Gateway reports exception 0x06 when queued requests are full.
Check TCP Header	<input type="checkbox"/> Drops packet when Modbus TCP header (protocol ID, length) is wrong.
<input type="button" value="Update Settings"/>	

The following is an overview of the parameters contained in the **Modbus Settings** section:

Item	Description	Default
Gateway Net ID	This is reserved for gateway. (Not used to set the slave device)	255
CRC Exception	This parameter is used to enable or disable whether the validity of the RTU/ASCII CRC of the slave response is checked. 0 = Returns the raw data, including the CRC, if a CRC error occurs; 1 = Reports a 0x43 exception code if a CRC error occurs; 2 = Drops the packet if a CRC error occurs.	1
Protocol Exception	This parameter is used to enable or disable whether the slave response is checked for compatibility with the Modbus RTU format. If the slave response is an invalid Modbus message, a 0x41 exception code will be reported. Enable =1; Disable = 0.	1

<p>Timeout Exception</p>	<p>This parameter is used to enable or disable whether a slave/data timeout exception error is reported by the Gateway. If there is no response from a slave device, a 0x0B exception error will be reported. If serial data is being received, a 0x4B exception will be reported.</p> <p>Enable =1; Disable = 0.</p>	<p>1</p>
<p>Busy Exception</p>	<p>This parameter is used to enable or disable whether a busy exception code (0x06) is reported if the Gateway request queue is full.</p> <p>Enable =1; Disable = 0.</p>	<p>1</p>
<p>Check TCP Header</p>	<p>This parameter is used to enable or disable the drop-packet function when the Modbus TCP header is invalid.</p> <p>Enable = 1; Disable = 0.</p>	<p>1</p>
<p>Update Settings</p>	<p>Click this button to save the revised settings to the tGW-700/GW-2200.</p>	

5.3.4 Other Operations

The **Other Operations** section contains the operating interface for restoring factory defaults, rebooting the module, and remotely updating the firmware.

Other Operations

Restore all options to their factory default states	Restore Defaults
Reboot the module	Reboot
Firmware update via Ethernet If the remote firmware update is failed, then on-site firmware update is required to make the module working again. Step 1: Refer to firmware update manual first. Step 2: Run eSearch Utility to prepare and wait for update. Step 3: Click the [Update] button to reboot the module and start update. Step 4: Configure the module again.	Update

Restoring factory defaults

Use the following procedure to reset all parameters to their original factory defaults:

Step 1: Click the “Restore Defaults” button to reset the configuration.

Step 2: Click the “OK” button in the message dialog box.

Step 3: Check whether the module has been reset to the original factory default settings for use with the eSearch Utility. Refer to [Chapter 3 “Getting Started for tGW-700/GW-2200 series using IPv4”](#), [Chapter 4 “Getting Started for tGW-700/GW-2200 series using IPv6”](#) for more details.

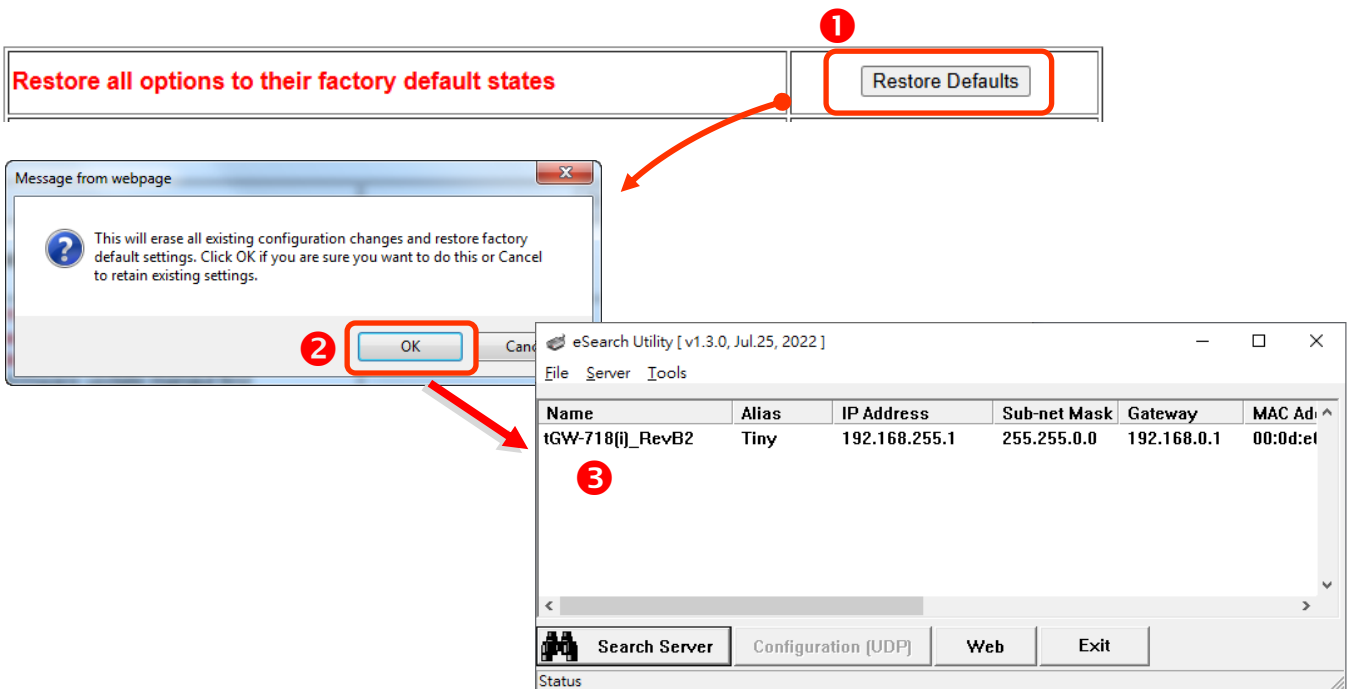

The following is an overview of the factory default settings:

IPv4 Network Settings		IPv6 Network Settings		Basic Settings	
IPv4 Address	192.168.255.1	User-defined	fc00::1	Alias	Tiny
Gateway Address	192.168.0.1	Link-Local	Auto-configure		
Subnet Mask	255.255.0.0	SLAAC	Auto-configure		
DHCP	Disabled				

■ Rebooting the module

Clicking the **Reboot** button can force the tGW-700/GW-2200 module to reboot remotely without power cycle the module. After the module has rebooted, you will be prompted to login again.

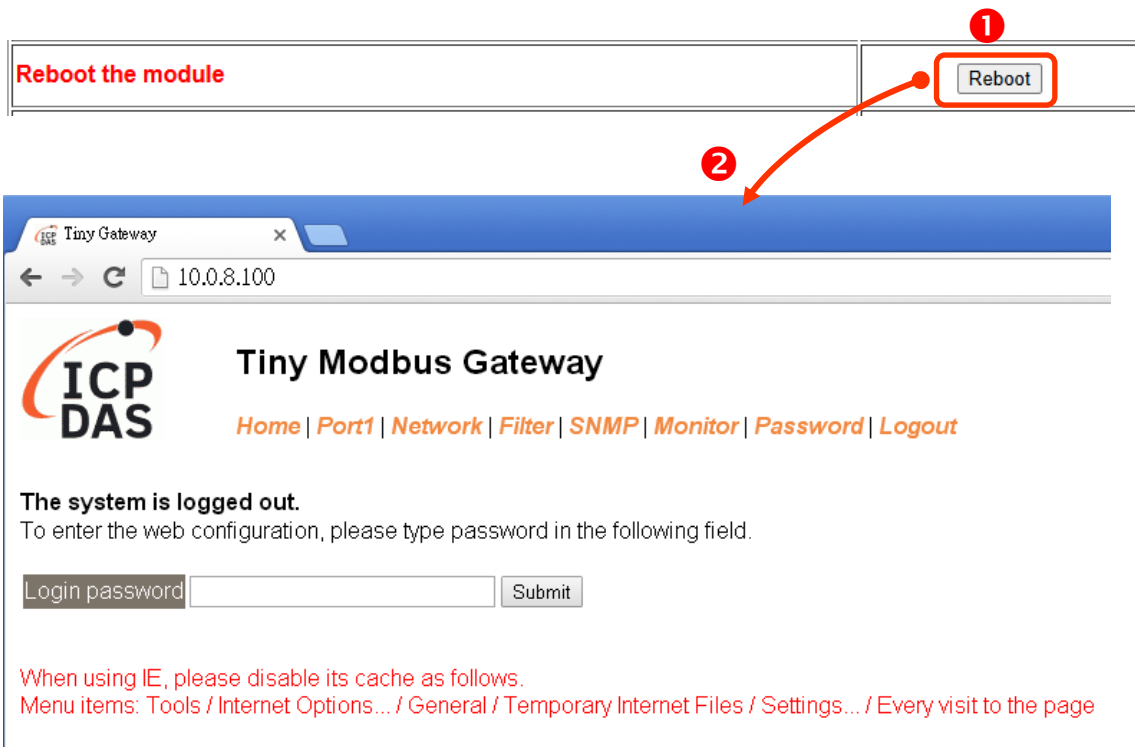

■ Rebooting the module

Firmware update requires initialization and local network operations. Regular firmware update requires adjusting the Init/Run switch and reboots the module manually for the initialization of firmware update, while new firmware allows user to initialize the module via web interface without adjusting the hardware switch. Initialization via web is useful when module is installed in remote site and can be accessed by a remote PC via TeamViewer.

Firmware update via Ethernet

If the remote firmware update is failed, then on-site firmware update is required to make the module working again.

Step 1: Refer to firmware update manual first.

Step 2: Run eSearch Utility to prepare and wait for update.

Step 3: Click the **[Update]** button to **reboot** the module and start update.

Step 4: Configure the module again.

Update

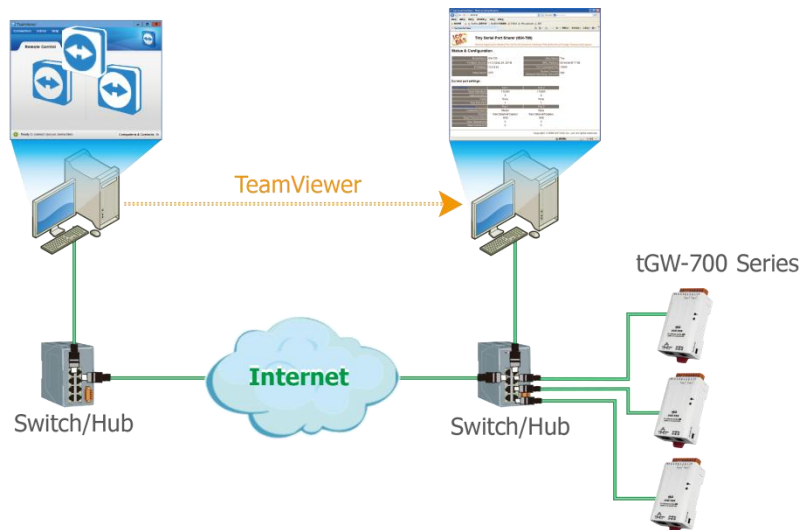

Note:

If the remote firmware update is failed, then the traditional firmware update (Local) is required to make the module working again.

For detailed information regarding how to use this function to update the Firmware for tGW-700/GW-2200 series module, refer to the “tGW-700 Firmware Update Manual (EN)”, “GW-2200 Firmware Update Manual (EN)”. The download address is shown below:

tGW-700 :

<https://www.icpdas.com/en/download/show.php?num=2417>

GW-2200 :

<https://www.icpdas.com/en/download/show.php?num=2750>

5.4 Serial Port Page

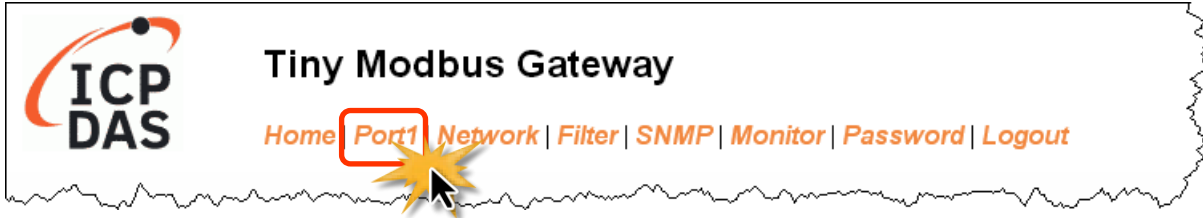

The serial port settings of the tGW-700/GW-2200 module are provided on the **Port1** page, allowing you to configure and view the parameters including the Baud Rate, Data Format, Slave Timeout, Char Timeout, Silent Time, Read Cache, TCP Timeout, Modbus Protocol and Pair-connection, each of which will be described in more detail below.

5.4.1 Settings (Port1 Settings)

The **Interface Settings** setting appears only on the tGW-718i-D module; it does not appear on other modules. Select the interface from the drop-down menu. This interface setting is based on the wiring used to connect to your Modbus device. For detailed instructions, refer to [Section 3.3, Connecting the Modbus Devices](#).

Port 1 Settings

Interface Settings	Current	Updated	Comment
Interface	RS-232	RS-232 ▼	Internal loopback is for test only.
Pull-High/Low Resister	Disable	Disable ▼	Supports RS-485 or RS-422 only.
Terminal Resister	Disable	Disable ▼	Supports RS-485 or RS-422 only.

Item	Description	Default
Interface Settings		
Interface	Sets the interface mode (Loopback, RS-232, RS-422 or RS-485) of serial port for the tGW-718i-D only . Loopback: the internal loopback is used to self-testing.	RS-232
Pull-High/Low Resister	Enables or disables pull-high/low resister for RS-485 or RS-422 of the tGW-718i-D only (1K Ohm) .	Disable
Terminal Resister	Enables or disables terminal resister for RS-485 or RS-422 of the tGW-718i-D only (120 Ohm) .	Disable

Port Settings		Current	Updated	Comment
Baud Rate	115200	115200	(select)	bps (bits/second)
Data Size	8	8		bits/char
Parity	None	None		
Stop Bits	1	1		
Flow Control	None	None		
Remove Errors	FE BE	<input type="checkbox"/> Parity Error <input checked="" type="checkbox"/> Framing Error <input checked="" type="checkbox"/> Break Error		Clear RX FIFO data when serial errors.
Modbus Settings		Current	Updated	Comment
Slave Timeout	300	300		10 - 65000 ms (step 10), Default: 300. (Note)
Char Timeout	4	4		4 - 15 bytes, Default: 4
Silent Time	0	0		0 - 65000 ms (step 10), Default: 0
Protocol	Modbus RTU	Modbus RTU		
Virtual ID Range	0 - 247	0	to 247	Range: 0 to 247. Note: Gateway skips the Modbus messages if its ID is NOT in the specified range.
Virtual ID Offset	0	0		Offset: -246 to 246, No change=0. For example: Virtual ID = 1 to 10, offset = 10, then physical Slave ID = 11 to 20. Virtual ID = 31 to 40, offset = -10, then physical Slave ID = 21 to 30.
Modbus TCP Settings		Current	Updated	Comment
Queue Timeout	1000	1000		1000 - 65000 ms (step 10), Default: 1000. (Note)
Read Cache	980	980		0 - 65000 ms (step 10), Disable: 0
Local TCP Port	502	502		Default: 502
MTCP Length Swap	0	0		0:TX/RX=High byte first. 1:TX=High, RX=Low byte first. 3:TX/RX=Low byte first. 2:TX=Low, RX=High byte first.
Connection Idle	180	180		0 - 65000 seconds, Default: 180, Disable: 0
Pair-Connection Settings (Master/Slave Mode)		Current	Updated	Comment
Application Mode	Server	Server		Server: Modbus TCP/UDP master to Modbus RTU/ASCII slave Client: Modbus RTU/ASCII master to Modbus TCP/UDP slave

Item	Description	Default
Port Settings		
Baud Rate (bps)	Sets the Baud Rate for the COM ports.	115200
Data Size (bits)	Sets the Data Size for the COM ports.	8
Parity	Sets the Parity for the COM ports.	None
Stop Bits (bits)	Sets the Stop Bits for the COM ports.	1
Flow Control	Enables or disables hardware flow control (CTS/RTS) function for the tGW-712, tGW-722, tGW-724, GW-2212i, GW-2222i and GW-2232i only.	None
Remove Errors	Clears the Rx FIFO when the Parity, Framing, Break Error occurs.	FE, BE

Item	Description	Default
Modbus Settings		
Slave Timeout (ms)	<p>Sets the waiting time that should elapse after last character of the request sent to the device before the timeout is activated. The tGW-700/GW-2200 will report a 0x0B exception code if there is no response from the slave device before the timeout period expires, or will report a 0x4B exception code if the slave device is still sending data when the timeout is activated.</p> <p>The Slave Timeout value must be set to less than the response timeout configured in the client software.</p>	300
Char Timeout (bytes)	<p>Modbus RTU requires 3.5 char time between messages.</p> <p>This parameter is used to set the waiting time (based on bytes) that should elapse after last byte of data of the response is received from the slave device is activated. If no more data is received before the timeout period expires, then the transmission of this packet is deemed to have been completed and the tGW-700/GW-2200 begins processing the packet.</p> <p>Range: 4 to 15 bytes</p>	4
Silent Time (ms)	<p>Sets the idle time that should elapse before sending each request to the serial port. This causes the serial bus to be "silent" for the specified period, and allows slower slave devices more time to process previous requests and responses, thereby reducing communication problems.</p> <p>Range: 0 to 65000 ms (step 10)</p>	0
Protocol	Sets the protocol (Modbus RTU or Modbus ASCII) for the serial port.	Modbus RTU
Virtual ID Range	<p>Sets the range for restricting the Device ID.</p> <p>This port only handles the Net ID in the range.</p>	1-247
Virtual ID Offset	<p>Sets the offset value for the Device ID.</p> <p>For more detailed information regarding the mapping configuration for the Virtual ID Range and the Virtual ID Offset, refer to "FAQ: How do I access multiple Modbus TCP slave devices from a single Modbus RTU/ASCII master device."</p>	0

Item	Description	Default
Modbus TCP Settings		
Queue Timeout	<p>The request commands sent from the master are first stored in the queue buffer and then forwarded to the slave devices in sequence. If a message cannot be forwarded within the specified time, the master will receive an error code 0x06.</p> <p>Range: 1000 to 65000 ms, (step 10)</p>	1000
Read Cache (ms)	<p>When multiple master devices need to access the same Modbus RTU/ASCII devices or data, the read-cache function can be enabled. This reduces the communication load on the serial interface and provides faster response times over TCP.</p> <p>Range: 10 to 65000 ms (step 10); Disable = 0.</p>	980
Local TCP Port	<p>This parameter is used to configure the Modbus TCP port.</p> <p>Note: The default COM1/COM2/COM3 = TCP Ports 502/503/504.</p>	502
MTCP Length Swap	<p>Swaps the High/Low byte reading order of Length in the Modbus TCP header.</p> <p>0: TX/RX = High byte first, 1: TX = High byte first, RX = Low byte first, 2: TX = Low byte first, RX = High byte first, 3: TX/RX = Low byte first.</p>	0
Connection Idle (seconds)	<p>Defines the TCP timeout. If no data is received on the TCP port within this timeout period, the system will automatically terminate the connection.</p> <p>Range: 1to 65000 seconds; Disable= 0.</p>	180

5.4.2 Settings (Pair-Connection Settings)

Pair-Connection Settings (Master/Slave Mode)	Current	Updated	Comment
Application Mode	Server	<input type="button" value="Client"/> ▾	Server=Slave, Client=Master
Network Protocol	TCP / IPv4	<input type="button" value="TCP / IPv4"/> ▾	
Remote Server IP	0.0.0.0	<input type="text" value="0.0.0.0"/>	For example : IPv4 = 10.0.8.100 IPv6 = fc00::1000
Remote TCP Port	504	<input type="text" value="504"/>	
<input type="button" value="Submit"/>			

The following is an overview of the parameters contained in the **Settings – Pair-Connection Settings (Master/Slave Mode)** section:

Item	Description	
Pair-Connection Settings (Master/Slave Mode)		
Application Mode	Server (default)	Client
Network Protocol	-	Selects the Modbus protocol (Modbus TCP or UDP) and the Internet protocol (IPv4 or IPv6) for the remote device
Remote Server IP	-	Sets the IP address for the remote device
Remote TCP Port	-	Sets the TCP Port number for the remote device
Submit	Clicks this button to save the revised settings to the tGW-700/GW-2200.	

Note:

For more detailed information regarding pair-connection applications settings, refer to [Section 6.3 “Pair-Connection Applications”](#).

5.5 Filter Page



The **Filter** page is used to query or edit the IP Filter list. The IP Filter can restrict the access of packets based on the IP header. If the filter function is enabled, only clients whose IP is specified in the IP Filter list can access the tGW-700/GW-2200.

Filter Setting:

Accessible IP	IPv4/v6 Address (example: 10.0.8.123, fe80:0:0:0:a8ee:dc07:1cda:5678)
IP0	<input type="text"/>
IP1	<input type="text"/>
IP2	<input type="text"/>
IP3	<input type="text"/>
IP4	<input type="text"/>

Enable IP Filter Check to enable. (Default disabled)

1 (Red circle pointing to the IP input fields)

2 (Red circle pointing to the checkbox)

3 (Red circle pointing to the Update Setting button)

Update Setting (button)

Enables or disables IP Filter (yellow callout box)

Note: Remember to include the IP address of your configuration computer.

Enable the IP Filter:

Step 1: Enter the IP address that is allowed to access the module in the IP0 ~ IP4 fields.

Step 2: Tick the **Check to enable** checkbox in the Enable IP Filter field.

Step 3: Click the **“Update Setting”** button to update the settings.

Disable the IP Filter:

Step 1: Uncheck the **Check to enable** checkbox in the Enable IP Filter field.

Step 2: Click the **“Update Setting”** button to update the settings.

5.6 SNMP Page



The tGW-700/GW-2200 series module supports the standard SNMP v2c protocol. Through this protocol, the tGW-700/GW-2200 series module can transmit modules information to the SNMP Network Management Software or device to help administrators to monitor the status of the modules in real-time.

If the Trap function is enabled, the tGW-700/GW-2200 module can actively send messages to the SNMP manager terminal when the module restarts. The detailed description is as follows.

Note:

1. **SNMP function is available for Firmware v2.3.8 and later. It is not supported on older versions.**
 2. **The tGW-700/GW-2200 module currently supports these MIB-II management items such as sysContact, sysLocation, sysDescr, and sysName.**
-

5.6.1 SNMP Configuration Setting

SNMP v2c Agent Configuration

System Info	Setting	
Contact	User	(Max. 47 chars)
Location	Site	(Max. 47 chars)
Description	Modbus Gateway	(Max. 47 chars)
Name	Device	(Max. 47 chars)
Function	Setting	
Read-Only Community	public	(Max. 47 chars, example: public)
Read-Write Community	private	(Max. 47 chars, example: private)
Trap Community	public	(Max. 47 chars, example: public)
Manager / Trap IP #1	0.0.0.0	(IPv4/v6 Address, example: 10.0.8.123, fe80:0:0:0:a8ee:dc07:1cda:5678)
Manager / Trap IP #2	0.0.0.0	
Generic Trap	<input type="checkbox"/> Cold Start, <input type="checkbox"/> Warm Start	
Enable SNMP	<input type="checkbox"/> Check to enable. (Default disabled)	
<input type="button" value="Update Settings"/>		

The following is an overview of the parameters contained in the **System Info** section:

Item	Description	Default Value
Contact	Sets the module contact person	User
Location	Sets the module location	Site
Description	Sets the description of the module	Modbus Gateway
Name	Sets the name of the module	Device

The following is an overview of the parameters contained in the **Function** section:

Item	Description	Default Value
Read-Only Community	Sets the community name of the module for read-only data	public
Read-Write Community	Sets the community name of the module for read-write data	private
Trap Community	Sets the community name of the module for the trap	public
Manager / Trap IP #1	Sets the IP address of Trap IP #1	0.0.0.0
Manager / Trap IP #2	Sets the IP address of Trap IP #2	0.0.0.0
Generic Trap	Enables or disables the Cold Start or Warm Start function	Disabled
Enable SNMP	Ticks the Check to enable checkbox to enable the SNMP communication function or uncheck the item to disable it.	Disabled
Update Settings	Clicks this button to save the revised settings to the tGW-700/GW-2200. The new settings will be valid after the next power-on.	

5.6.2 SNMP I/O Example

This article takes iReasoning MIB Browser V14 as an example (hereinafter referred to as MIB Browser). Please download the installer program from its official website and run the installer.

<http://www.ireasoning.com/mibbrowser.shtml>

Step 1: Start the MIB Browser.

Click the **File => Load MIBs** on the menu bar and click the specified MIB file of the module (e.g. ICPDAS-tGW700-MIB_20220711.mib), then click the Open button to open it.

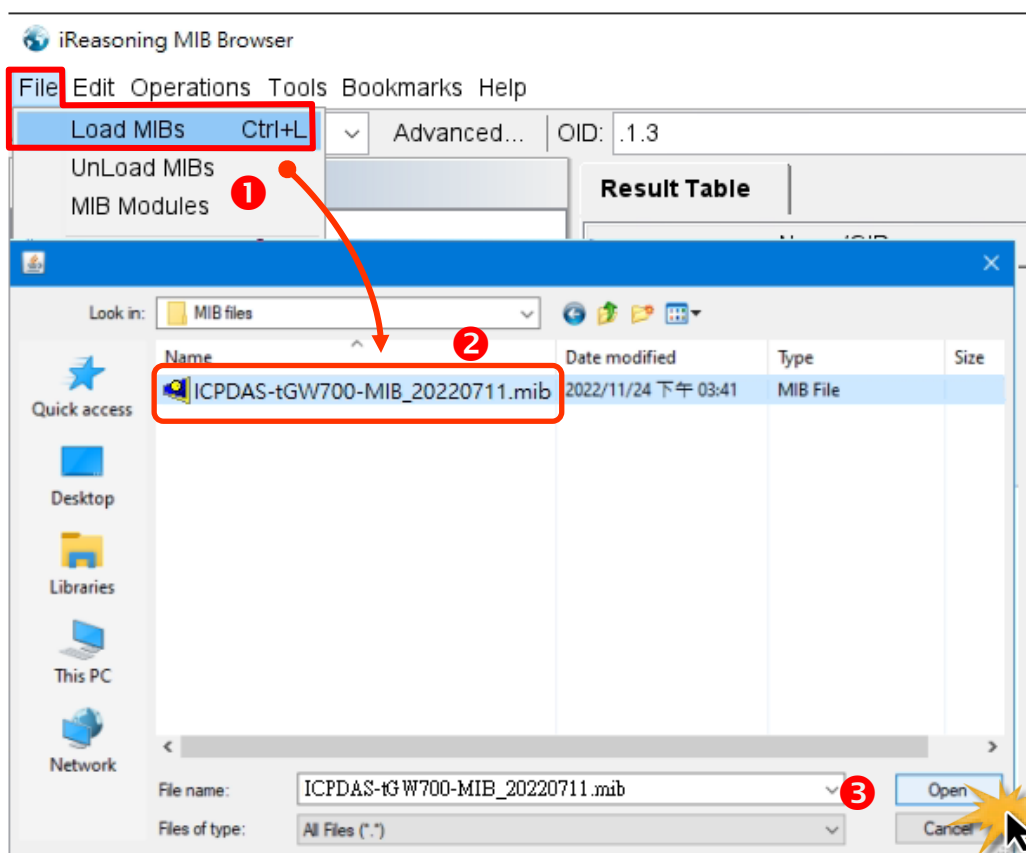

Step 2: Enter the IP address of the tGW-700/GW-2200 module in the **Address** field.

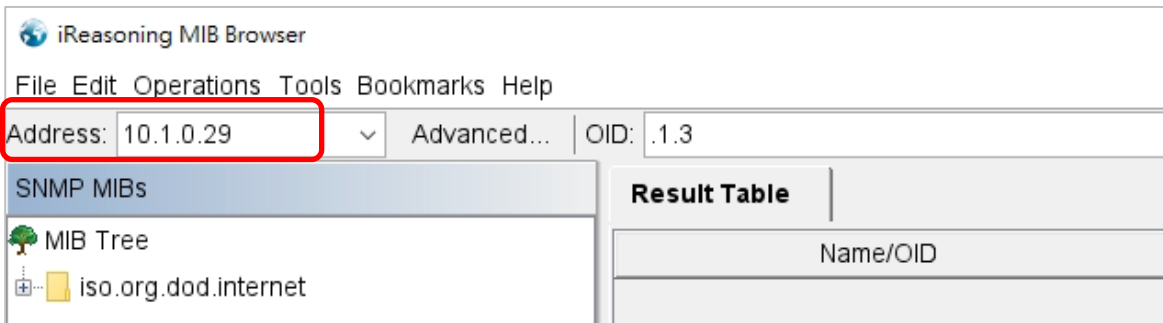

Step 3: Click “**Advanced**” to set the parameters of the SNMP agent. Enter the string in the Read/Write Community fields according to the Read-Only Community / Read-Write Community settings on the tGW-700/GW-2200. If these strings are different on both sides, the agent will not work correctly.

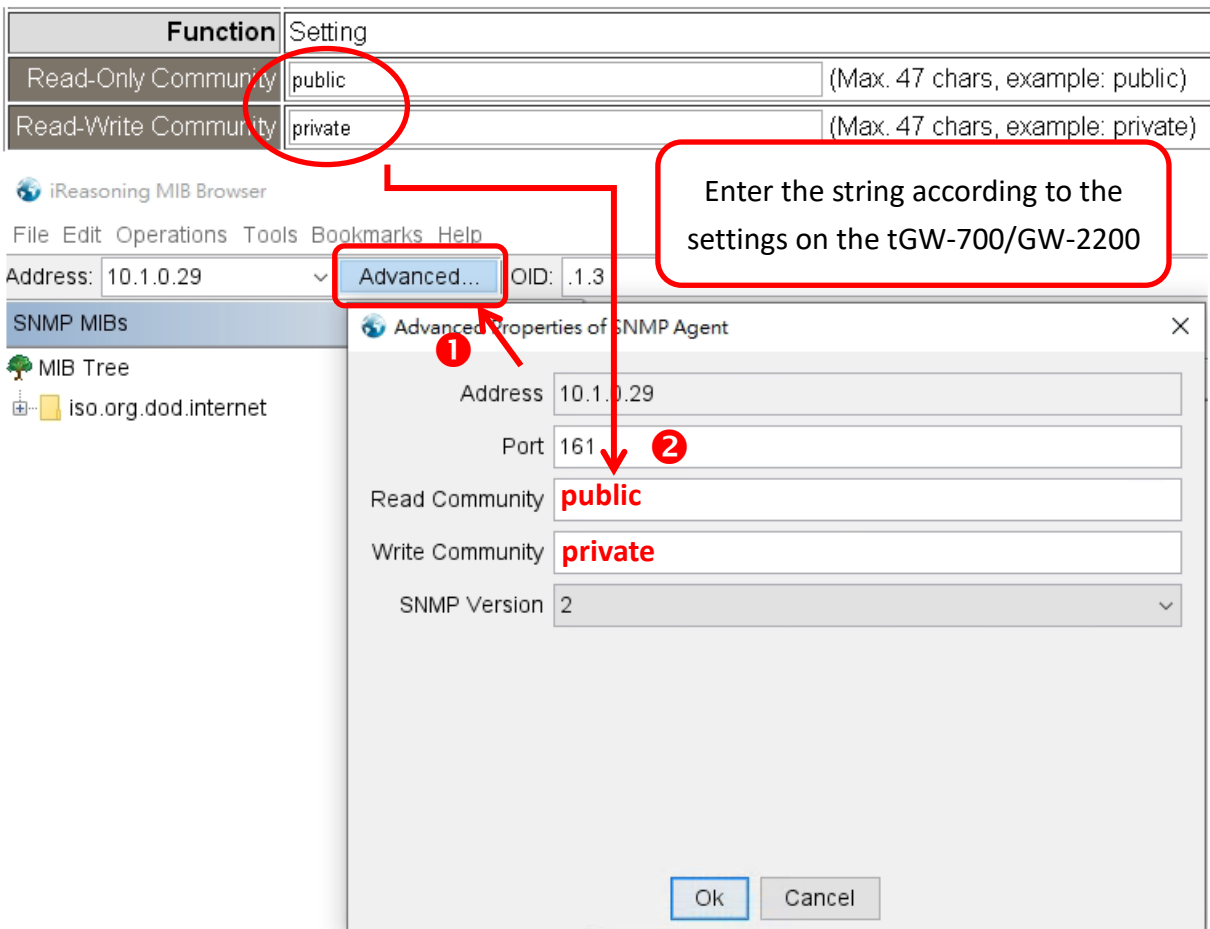

Note: If the Write Community field is not set, a Timeout error will occur during execution.

Step 4: Enter the IP address of MIB Browser in the **Manager/Trap IP #1** field, check the **Check to enable** checkbox to enable the SNMP function, then click” **Update Settings**” to save the changes. Finally, click the **“Reboot”** button to reboot the tGW-700/GW-2200 module.

Function	Setting
Read-Only Community	public (Max. 47 chars, example: public)
Read-Write Community	private (Max. 47 chars, example: private)
Trap Community	public (Max. 47 chars, example: public)
Manager / Trap IP #1	10.1.0.39 (IPv4/v6 Address, example: 10.0.8.123, fe80:0:0:0:a8ee:dc07:1cda:5678)
Manager / Trap IP #2	0.0.0.0
Generic Trap	<input type="checkbox"/> Cold Start, <input type="checkbox"/> Warm Start
Enable SNMP	<input checked="" type="checkbox"/> Check to enable. (Default disabled)

Update Settings

Reboot is required after SNMP configuration.

Read the information of the tGW-700/GW-2200 – The Walk command

Right-click the **iso.org.dod.internet** folder on the left side and click **Walk** to display the information of the tGW-700/GW-2200 in the **Result Table**

The screenshot shows the iReasoning MIB Browser interface. The address is set to 10.1.0.29 and the OID is .1.3.6.1. The MIB Tree on the left shows the folder **iso.org.dod.internet** selected, with a context menu open. The **Walk** option (Ctrl+W) is highlighted. A red arrow points from the **Walk** option to the **Result Table** on the right.

Name/OID	Value	Type	IP:Port
snmpInSetRequests.0	0	Counter32	10.1.0.29...
snmpInGetResponses.0	0	Counter32	10.1.0.29...
snmpInTraps.0	0	Counter32	10.1.0.29...
snmpOutTooBig.0	0	Counter32	10.1.0.29...
snmpOutNoSuchNames.0	0	Counter32	10.1.0.29...
snmpOutBadValues.0	0	Counter32	10.1.0.29...
snmpOutGenErrs.0	0	Counter32	10.1.0.29...
snmpOutGetRequests.0	0	Counter32	10.1.0.29...
snmpOutGetNexts.0	0	Counter32	10.1.0.29...
snmpOutSetRequests.0	0	Counter32	10.1.0.29...
snmpOutGetResponses.0	3	Counter32	10.1.0.29...
snmpOutTraps.0	0	Counter32	10.1.0.29...
snmpEnableAuthenTraps.0	disabled (2)	Integer	10.1.0.29...
.1.3.6.1.2.1.11.31.0	0	Counter32	10.1.0.29...
.1.3.6.1.2.1.11.32.0	0	Counter32	10.1.0.29...
modelName.0	tGW-715/715i_RevB2	OctetString	10.1.0.29...
aliasName.0	Tiny	OctetString	10.1.0.29...
firmwareVersion.0	B2.3.8 [May.11 2023]	OctetString	10.1.0.29...
webServerPort.0	80	Integer	10.1.0.29...
comIndex.1	1	Integer	10.1.0.29...
comName.1	Port1	OctetString	10.1.0.29...
modbusTcpPort.1	502	Integer	10.1.0.29...
modbusTcpPort.1	(Snmp End Of Mib View)	EndOfMi...	10.1.0.29...

5.6.3 SNMP Trap Example

Step 1: Click **Tools => Trap Receiver** on the menu bar to display the window for receiving the Trap messages.

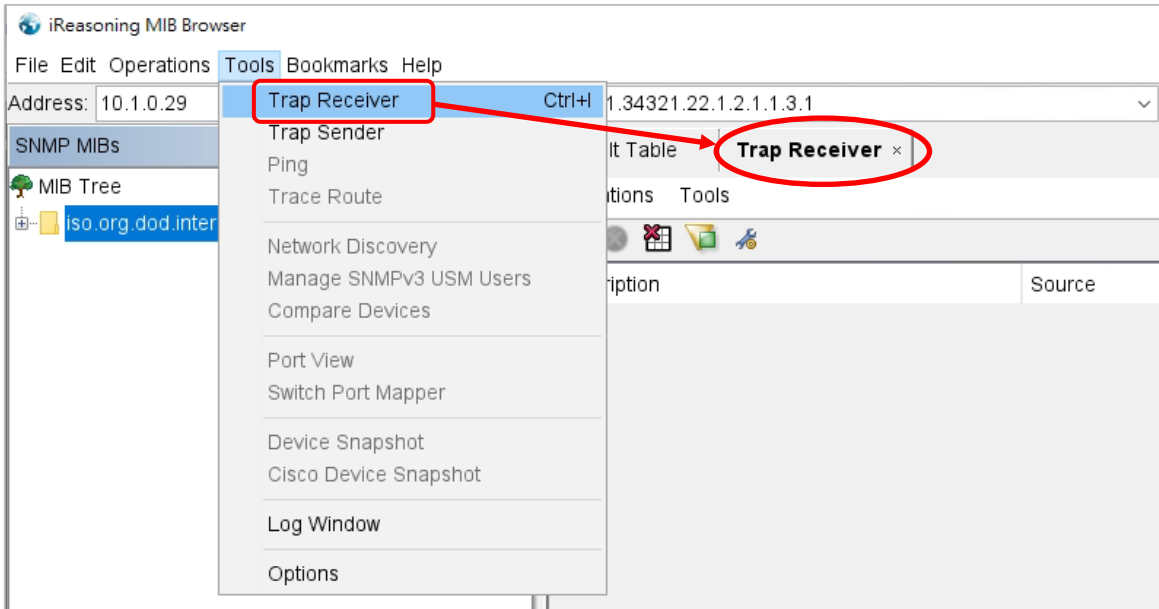

Step 2: The Trap types for the alarms that receive from the tGW-700/GW-2200 module are as follows.

1. Cold Start Trap:

The Cold Start Trap will be sent when the module restarts after it has been powered off.

2. Warm Start Trap:

The Warm Start Trap will be sent when the module restarts without turning off the power, for example, the reboot command or the watchdog mechanism.

Click the Trap message to view the details

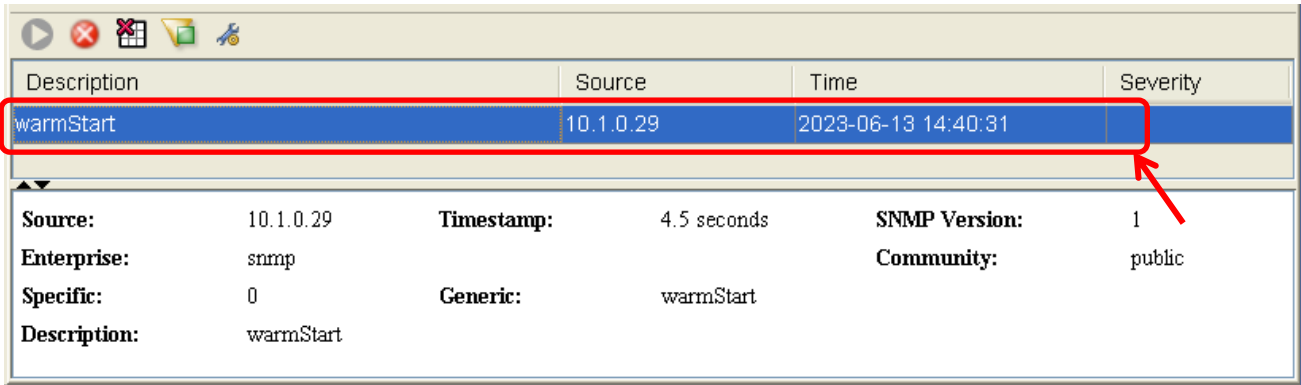

Item	Description
Source	The IP address of the Trap from the module.
Timestamp	The time elapsed since the last startup of the module.
SNMP Version	The version of SNMP
Enterprise	The name of the enterprise
Community	SNMP community name according to the Trap Community setting on the tGW-700/GW-2200
Specific	Specific ID.
Generic	Generic ID.
Description	Trap Information

5.6.4 SNMP Troubleshooting

Unable to receive the Trap message from the module

1. Check the setting of the Windows firewall or the Anti-virus software. These functions can be disabled during the testing
2. Check the setting of the Trap port. Using **iReasoning MIB Browser** as an example:

Click the **Trap Receiver Settings** button on the **Trap Receiver** page to open the window. Then, confirm the **Trap Port**, **Bind IP**, and **Transport** settings. The tGW-700/GW-2200 uses the default Trap port 162 according to the SNMP specification.

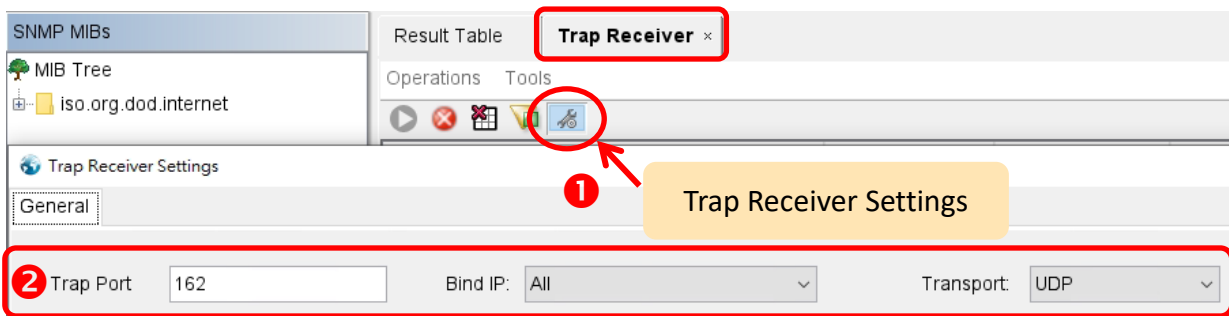

3. Disable Windows SNMP Trap Service

Note: The configuration screen varies according to the Windows version. The following screens are on Windows 10.

Step 1: Enter services.msc in the command bar and click to open the Windows service tool.

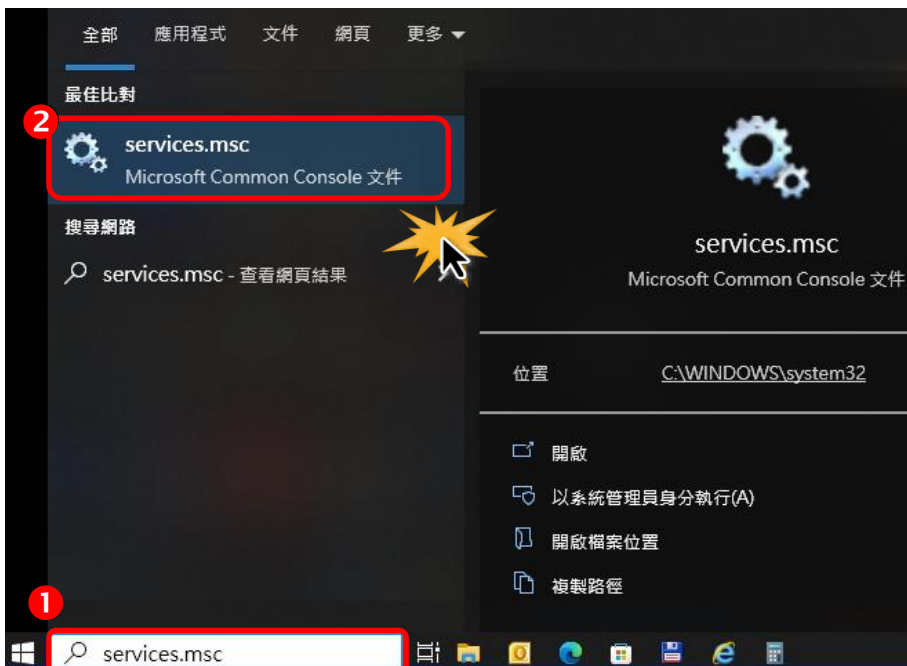

Step 2: Double-click the SNMP Trap and confirm the Startup type is set to “Disabled” and the Service status is set to “Stopped”.

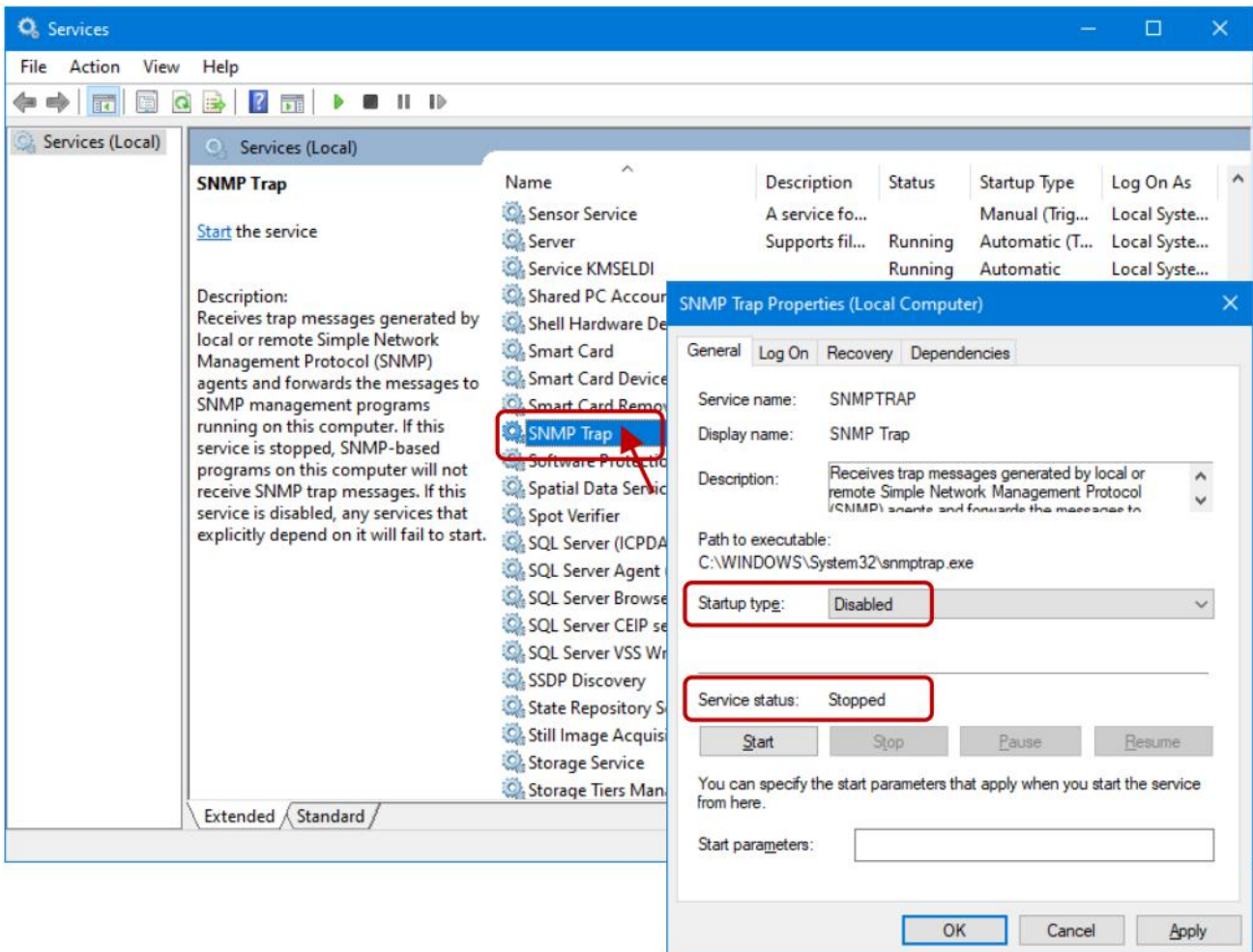

5.7 Monitor Page



Current Connection Status:

Connection	Port 1
Application Mode	TCP/UDP Server
Connected IP1	-
IP2	-
IP3	-
IP4	-
Available Connections	32
Host Query (Client mode)	Port 1
Query State	-
Last Query Time	-
Remote Server IP	-
Connection State	-
Modbus TCP/UDP	Port 1
Sent Packets	0
Received Packets	0
Dropped Packets	0
Queued Packets	0
(No Buffer) Busy Packets	0
(Queue-Timeout) Busy Packets	0
Last Sent	-
Last Received	-
Modbus RTU/ASCII	Port 1
Sent Packets	0
Received Packets	0
Dropped Packets	0
(No Response) Slave Timeouts	0
(Receiving) Slave Timeouts	0
Buffer Usages	0%
Cache Hits	0%
Last Sent	-
Last Received	-
Communication	Port 1
Maximum Response Time (ms)	0
First Error (Hex)	0,0,0
Last Error (Hex)	0,0,0
Remove PE/FE/BE (bytes)	0

Note:

1. for error codes and descriptions.
2. The "**Busy Error**" can occur if there are too many Modbus requests in the queue. To resolve this, increase timeout and scan time on all Master (Client) software.
3. The **Maximum Response Time** above is the round trip time between the Gateway and the Slave.

The **Monitor** page contains the information regarding the current status of the serial port connections as shown on the left.

5.8 Password Page



The login password can be modified on the **Password** page.
The following are the steps to change the password:

Step 1: Enter the old password in the “*Current password*” field.

Step 2: Enter the new password in the “*New password*” and “*Confirm new password*” fields.

Step 3: Click the “**Submit**” button to update the password.

A screenshot of the 'Change Password' form. The title 'Change Password' is at the top left. Below it is the instruction 'The length of the password is 12 characters maximum.' There are three input fields: 'Current password' with five dots, 'New password' with four dots, and 'Confirm new password' with four dots and a small eye icon. A 'Submit' button is to the right of the third field. A yellow starburst cursor is pointing to the 'Submit' button.

Note:

If you forgot password, please refer to [Section A1. How do I restore the web password for the module to the factory default password?](#)

5.9 Logout Page



After clicking **Logout**, you will be logged out of the system and returned to the login page.

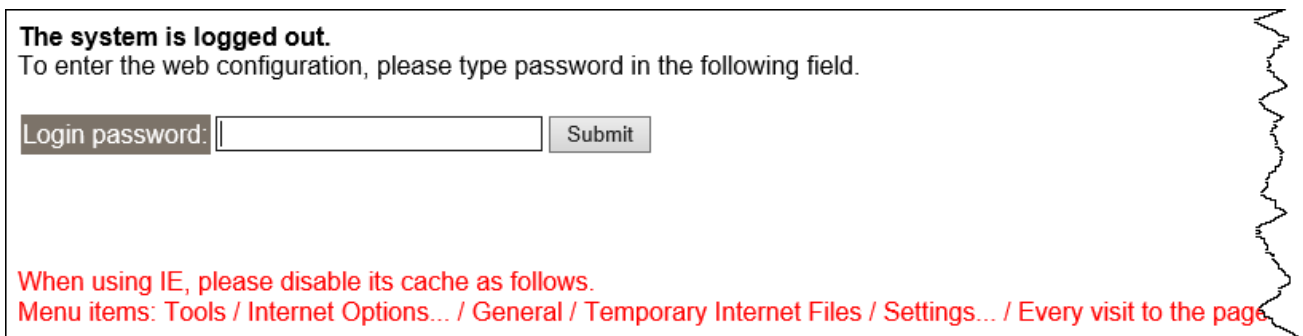

6. Typical Applications

This chapter provides some examples of typical scenarios for the tGW-700/GW-2200 series module, including applications focused on the Modbus Gateway, Modbus Net ID, Pair-connection and TCP Client Mode, etc...

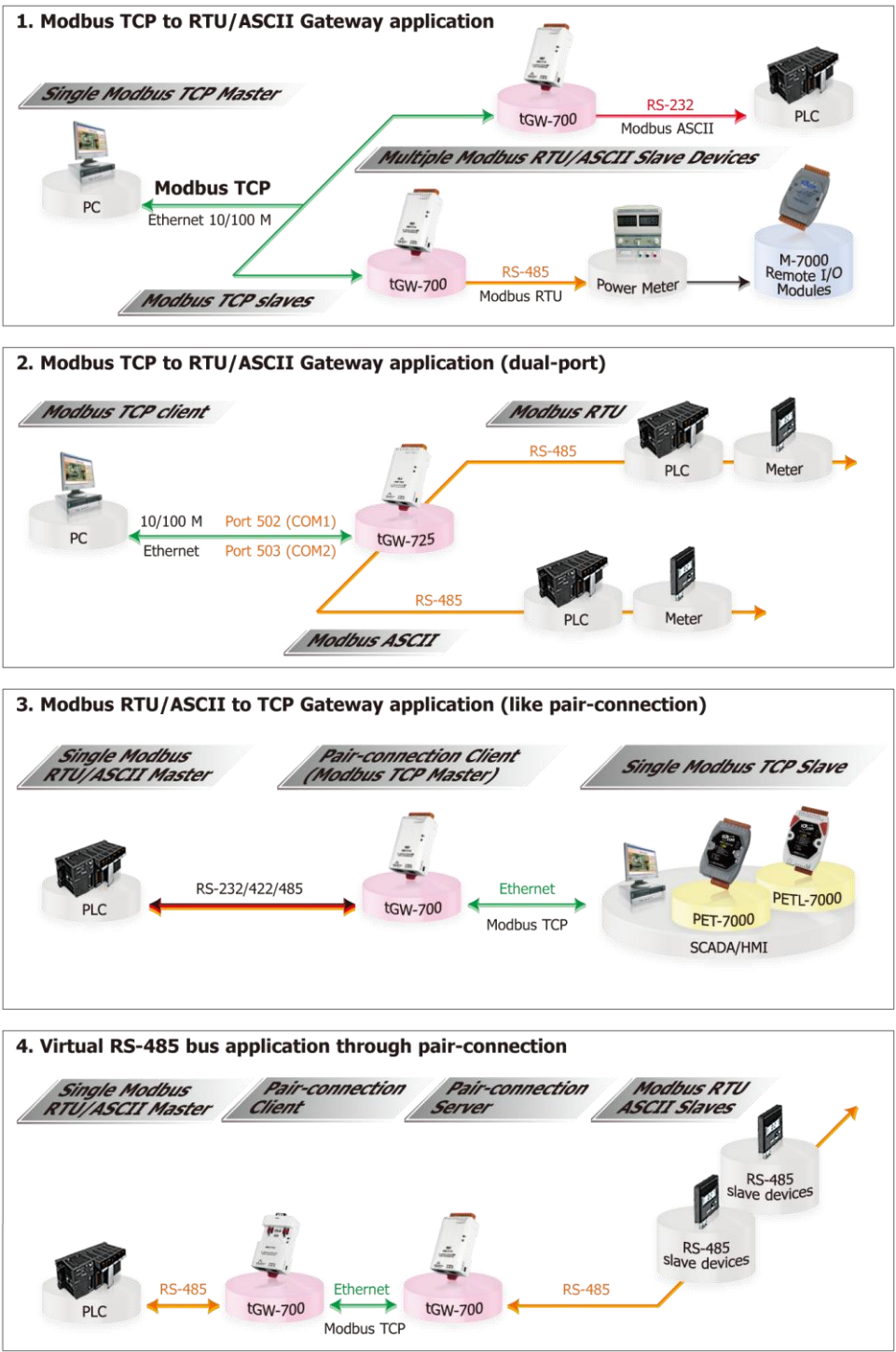

6.1 Modbus Gateway

The tGW-700/GW-2200 series module is a Modbus TCP/UDP to RTU/ASCII gateway that enables a Modbus TCP/UDP host to communicate with serial Modbus RTU/ASCII devices through an Ethernet network, and eliminates the inherent cable length limitations of legacy serial communication devices.

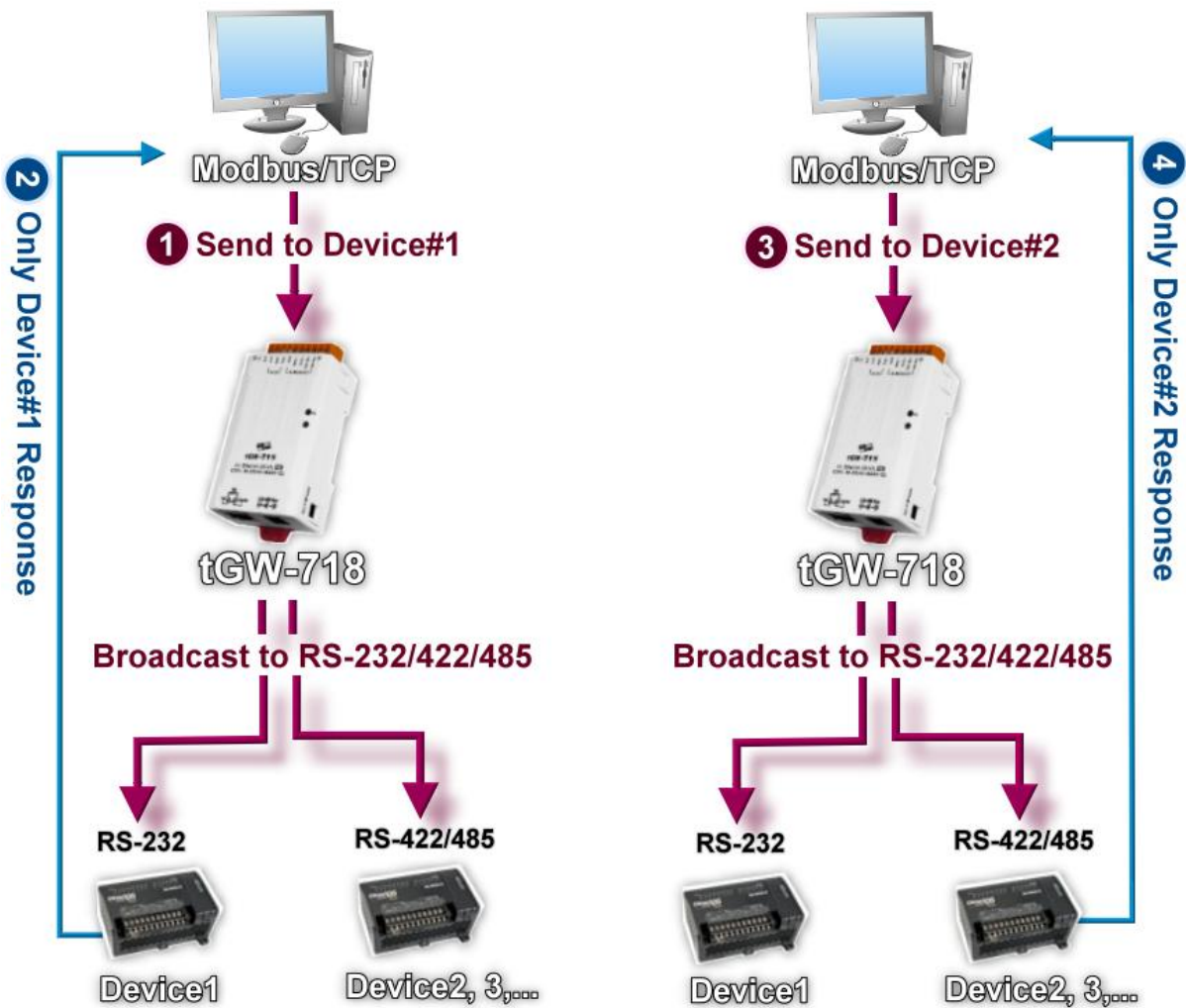

6.2 Modbus Net ID

The tGW-700/GW-2200 series module is a gateway that can be used to convert between the Modbus TCP/UDP protocol and the Modbus RTU/ASCII protocol. Consequently, SCADA/HMI applications is able to access each Modbus RTU/ASCII slave device via the tGW-700/GW-2200 gateway by specifying correct Net ID of the intended slave device in each Modbus TCP request.

Note that the Net ID of the tGW-700/GW-2200 gateway is reserved for specific control purposes, and is not used to access slave devices.

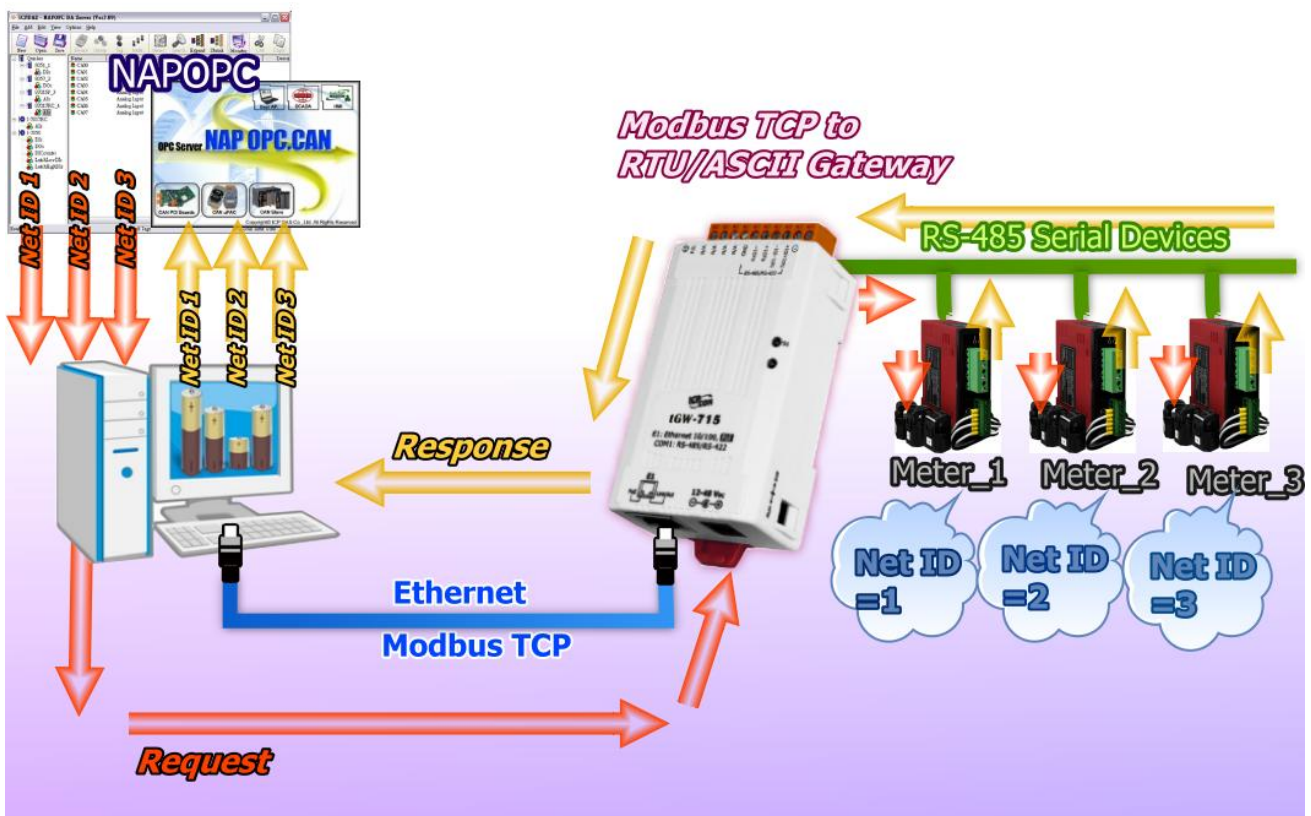

6.3 Pair-connection Applications

The tGW-700/GW-2200 Modbus gateway can be used to create a pair-connection applications (as well as serial-bridge or serial-tunnel), and then route Modbus messages between two serial devices via TCP/IP, which is useful when connecting Modbus RTU/ASCII devices that do not themselves have Ethernet capability.

The Pair-Connection Basis (Virtual RS-485 bus through the pair-connection)

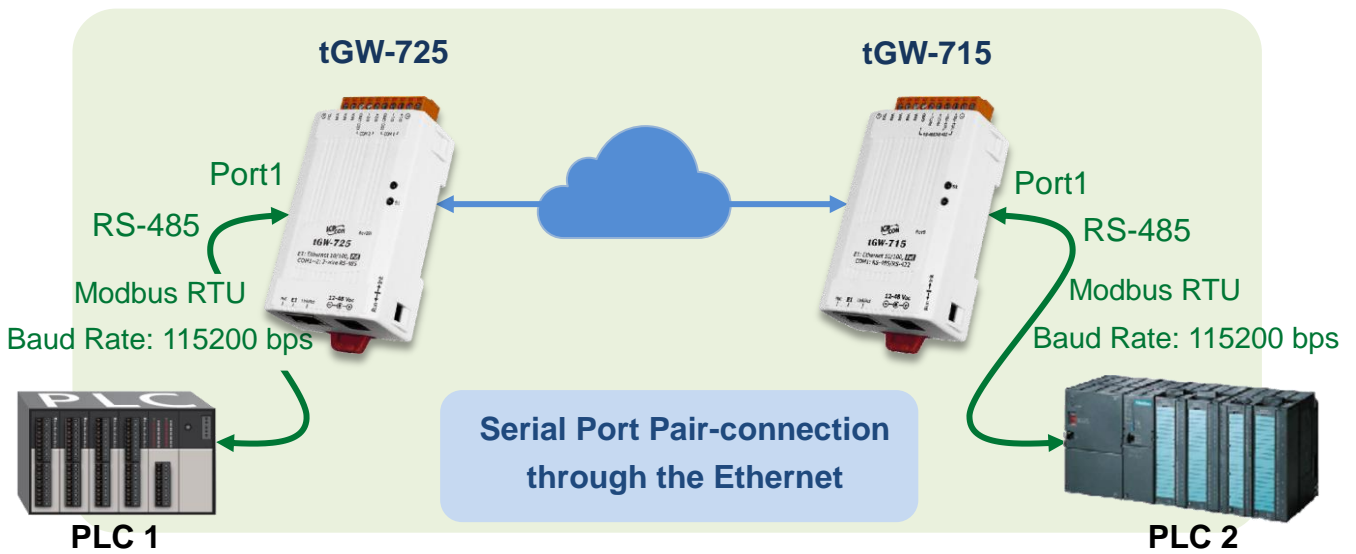

The Pair-connection with Different Baud Rate and Interfaces

(Modbus RTU to Modbus ASCII over Virtual RS-232 to RS-485 bus)

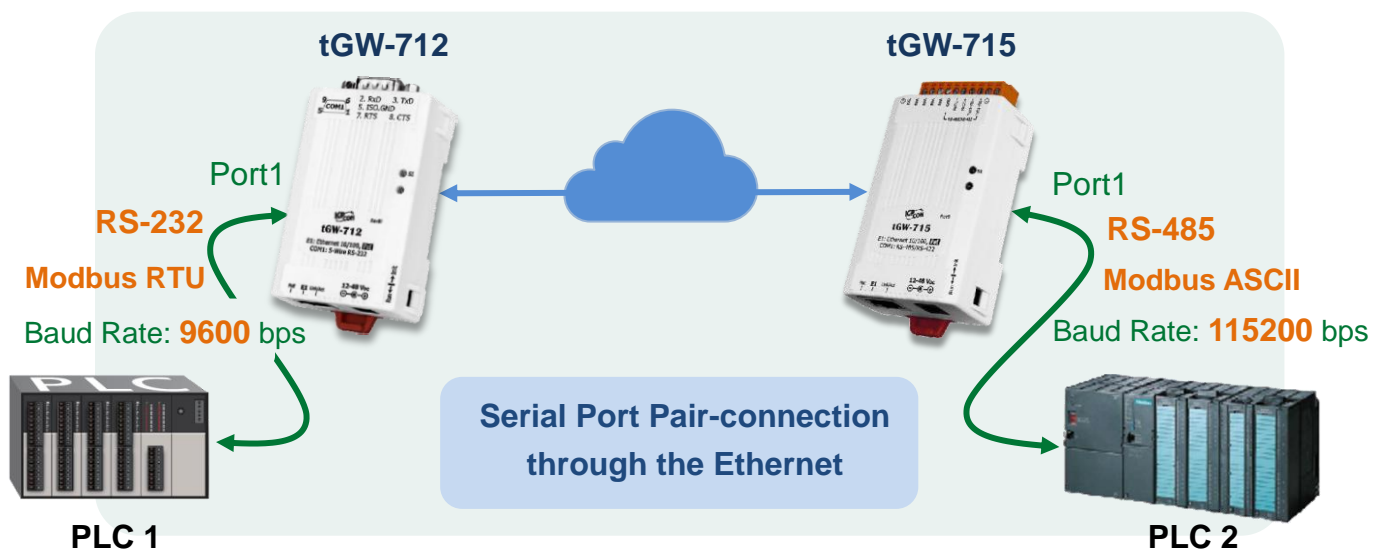

The following are examples of pair-connection tests:

➤ Pair-connection Settings:

Model	Port Settings (default)		Pair-connection Settings		
	Baud Rate	Data Format	Application Mode	Remote Server IP	Remote TCP Port (default)
tGW-700 #1	115200	8N1	Client	IP Address of tGW-700 #2	502
tGW-700 #2	115200	8N1	Server	-	-

Note: The Baud Rate and Data Format settings of the client and server (tGW-700 #1 and #2) depend on the COM ports of the PC (or the connected device). The serial port settings between tGW-700 #1 and tGW-700#2 can be different.

Step 1: Connecting to a network, PC and Power

1. Confirm that the tGW-700/GW-2200 modules are functioning correctly. For detailed information regarding how to install, configure and operate your tGW-700/GW-2200 series module, refer to [Chapter 3 “Getting Started for tGW-700/GW-2200 series using IPv4”](#), [Chapter 4 “Getting Started for tGW-700/GW-2200 series using IPv6”](#).
2. Use an I-7520 module (optional) to connect the COM1 of Host PC with COM1 of tGW-700 #1. For detailed information regarding RS-422/485 wiring, refer to [Section 2.5 “Wiring Notes for RS-232/422/485 Interfaces”](#).
(I-7520 product page: https://www.icpdas.com/en/product/I-7520_series)
3. Connect the Modbus device (e.g., M-7055D, optional) to COM1 of tGW-700 #2.
(M-7055D product page: <https://www.icpdas.com/en/product/M-7055D-G>)

➤ Refer to [Figure 6-1](#) for an illustration of how to perform **Steps 1-1 to 1-3** of the procedure described above.

The image below shows an example of the setup for a pair-connection test:

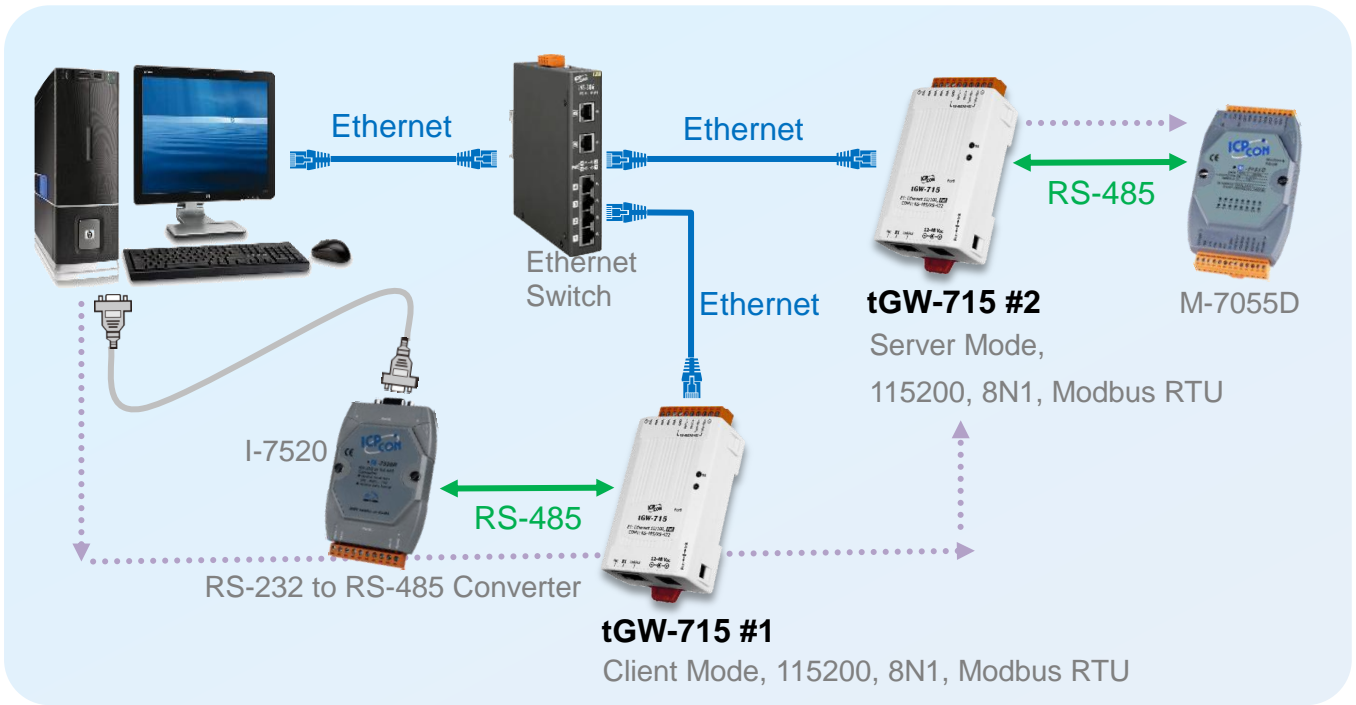

Figure 6-1

.....▶
Data request flow

Step 2: Configuring the Ethernet Settings

Contact your Network Administrator to obtain the correct and functioning network configuration for the tGW-700/GW-2200 modules (including the **IP Address, Mask and Gateway** details). Also refer to [Chapter 3 “Getting Started for tGW-700/GW-2200 series using IPv4”](#), [Chapter 4 “Getting Started for tGW-700/GW-2200 series using IPv6”](#) for more details.

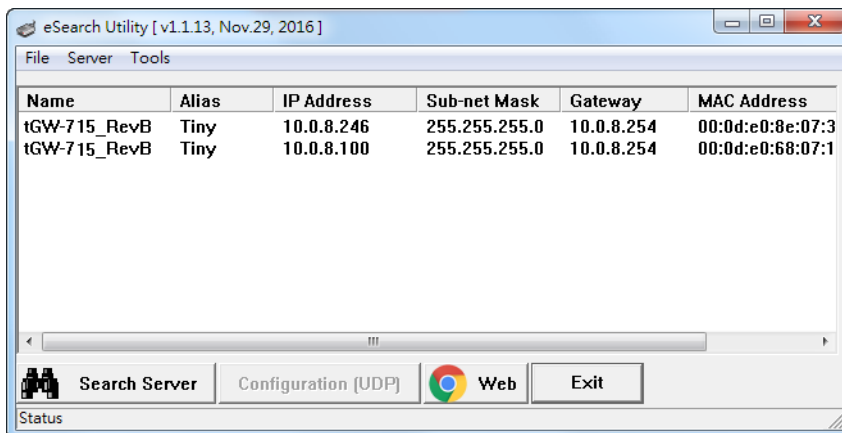

Figure 6-2

Step 3: Configuring the Pair-connection (Client Mode) on the Web Server for tGW-700#1

1. Open the eSearch Utility to search for the tGW-700/GW-2200 modules connected to the network. Click the name of the first tGW-700 module (tGW-700#1) to select it, and then click the **“Web”** button to launch a browser window to connect to the web server on the tGW-700 #1 module. Alternatively, you can enter the URL for tGW-700 #1 in the address bar of the browser.
2. When the login screen is displayed, enter the password in the **Login password** field, and then click the **“Submit”** button to display the configuration page.

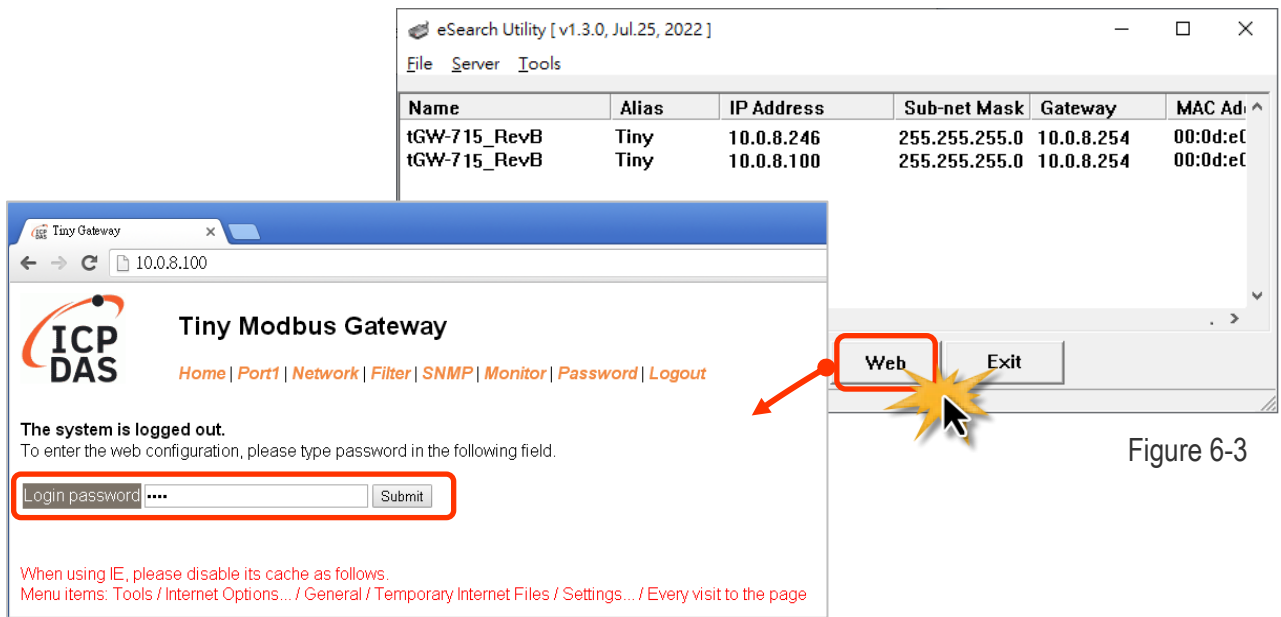

Figure 6-3

3. Click the **“Port1”** tab to display to the **Port1 Settings** page.



- Select the appropriate **Baud Rate, Data Format and Modbus Protocol** settings from the relevant drop down options. The following is an example: Baud Rate (bps) **“115200”**, Data Bits (bits) **“8”**, Parity **“None”**, Stop Bits (bits) **“1”** and Modbus Protocol **“Modbus RTU”**.

Port 1 Settings			
Port Settings	Current	Updated	Comment
Baud Rate	115200	115200 (select <input type="text"/>)	bps (bits/second)
Data Size	8	8 <input type="text"/>	bits/char
Parity	None	None <input type="text"/>	
Stop Bits	1	1 <input type="text"/>	
Flow Control	None	None <input type="text"/>	
Remove Errors	FE BE	<input type="checkbox"/> Parity Error <input checked="" type="checkbox"/> Framing Error <input checked="" type="checkbox"/> Break Error	Clear RX FIFO data when serial errors.
Modbus Settings	Current	Updated	Comment
Slave Timeout	300	300 <input type="text"/>	10 - 65000 ms (step 10), Default: 300. (Note)
Char Timeout	4	4 <input type="text"/>	4 - 15 bytes, Default: 4
Silent Time	0	0 <input type="text"/>	0 - 65000 ms (step 10), Default: 0
Protocol	Modbus RTU	Modbus RTU <input type="text"/>	

Figure 6-5

- In the **Pair-connection Settings** area for Port1, check that the configuration details are the same as those shown below.

Field	Application Mode	Network Protocol	Remote Server IP	Remote TCP Port
Pair-connection Settings	Client	TCP / IPv4	10.0.8.246	502
		Modbus Protocol, IP address and TCP port for tGW-700#2		

- Amend and details as required and then click the **“Submit”** button to complete the configuration.

Pair-Connection Settings (Master/Slave Mode)	Current	Updated	Comment
Application Mode	Client	Client <input type="text"/>	Server=Slave, Client=Master
Network Protocol	TCP / IPv4	TCP / IPv4 <input type="text"/>	
Remote Server IP	10.0.8.246	10.0.8.246 <input type="text"/>	For example : IPv4 = 10.0.8.100 IPv6 = fc00::1000
Remote TCP Port	502	502 <input type="text"/>	
<input type="button" value="Submit"/>			

Figure 6-6

Step 4: Configuring the Pair-connection (Server Mode) on the Web Server for tGW-700#2

1. In the eSearch Utility, click the name of the second tGW-700 module (tGW-700 #2) to select it, and then click the **“Web”** button to launch a browser window to connect to the web server on the tGW-700 #2 module. Alternatively, you can enter the URL for tGW-700 #2 in the address bar of the browser.
2. When the login screen is displayed, enter the password (use the default password **“admin”**) in the Password field, and then click the **“Submit”** button to display the configuration page.
3. Click the **“Port1”** tab to display the **Port1 Settings** page.
4. Select the appropriate **Baud Rate, Data Format and Modbus Protocol** settings from the relevant drop down options. The following is an example: Baud Rate (bps) **“9600”**, Data Bits (bits) **“8”**, Parity **“None”**, Stop Bits (bits) **“1”** and Modbus Protocol **“Modbus RTU”**.

➦ Refer to Figures 6-3 to 6-5 for an illustration of how to perform Steps 4-1 to 4-4 of the procedure described above.

5. In the **Pair-connection Settings** area for Port1, select **“Server”** from the **“Application Mode”** drop down options.
6. Amend any details as required and then click the **“Submit”** button to complete the configuration.

Pair-Connection Settings (Master/Slave Mode)	Current	Updated	Comment
Application Mode	Server	Server ▼	Server=Slave, Client=Master

Figure 6-7

Step 5: Testing the Pair-connection Functions

1. In the eSearch Utility, select the “**Modbus RTU Master**” item from the “**T**ools” menu to open the Modbus TCP Master Utility.

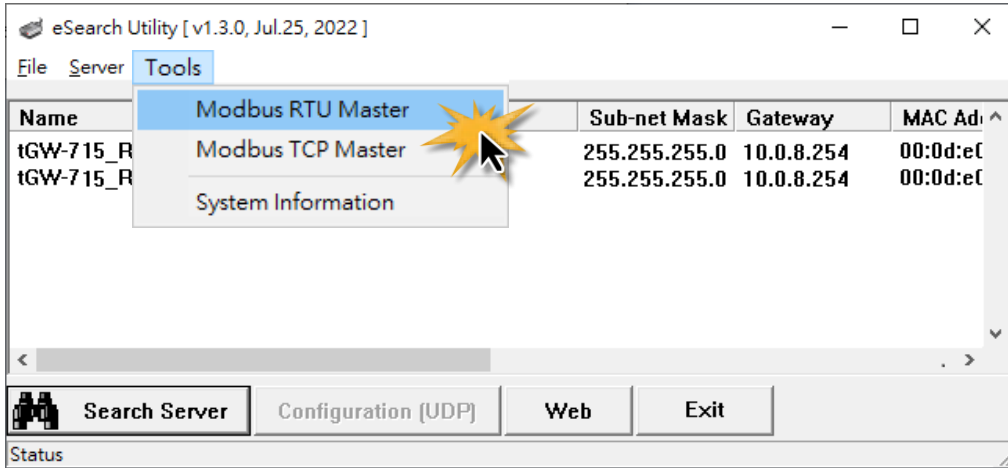

Figure 6-8

2. Select the appropriate COM port, Baud Rate and Data Format (e.g., COM1, 115200, N, 8, 1) settings for the tGW-700/GW-2200, and then click the “**O**pen” button.

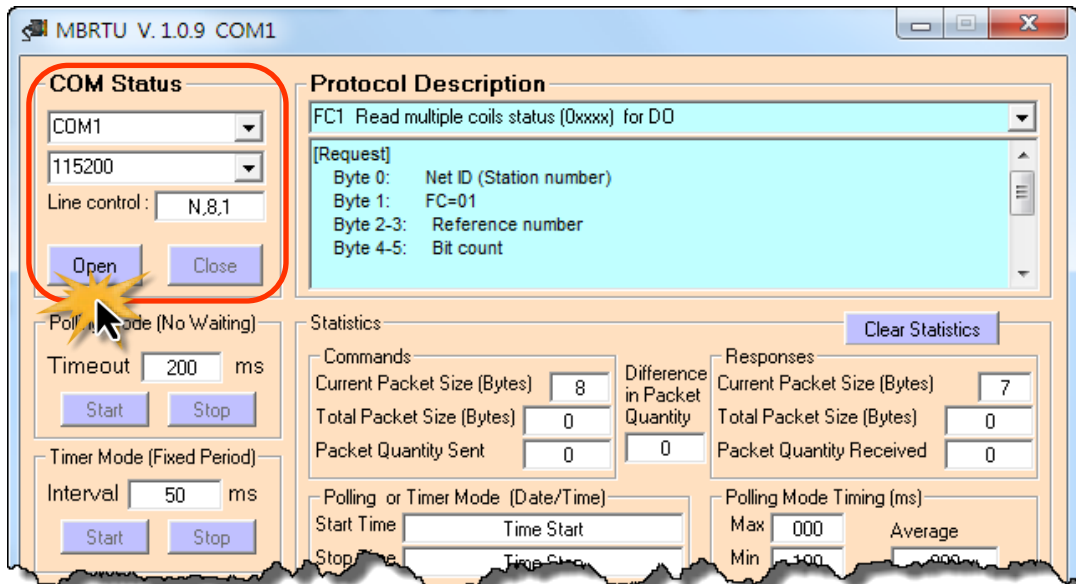

Figure 6-9

3. Refer to the **"Protocol Description"** field in the top right-hand section of the Modbus Utility window. You can **send a request command** and **confirm the response** is correct.

- Step 1: Enter the **Modbus command** in the **"Command"** field
- Step 2: Click the **"Send Command"** button.
- Step 3: If the **response data** is correct, it means the test is success.

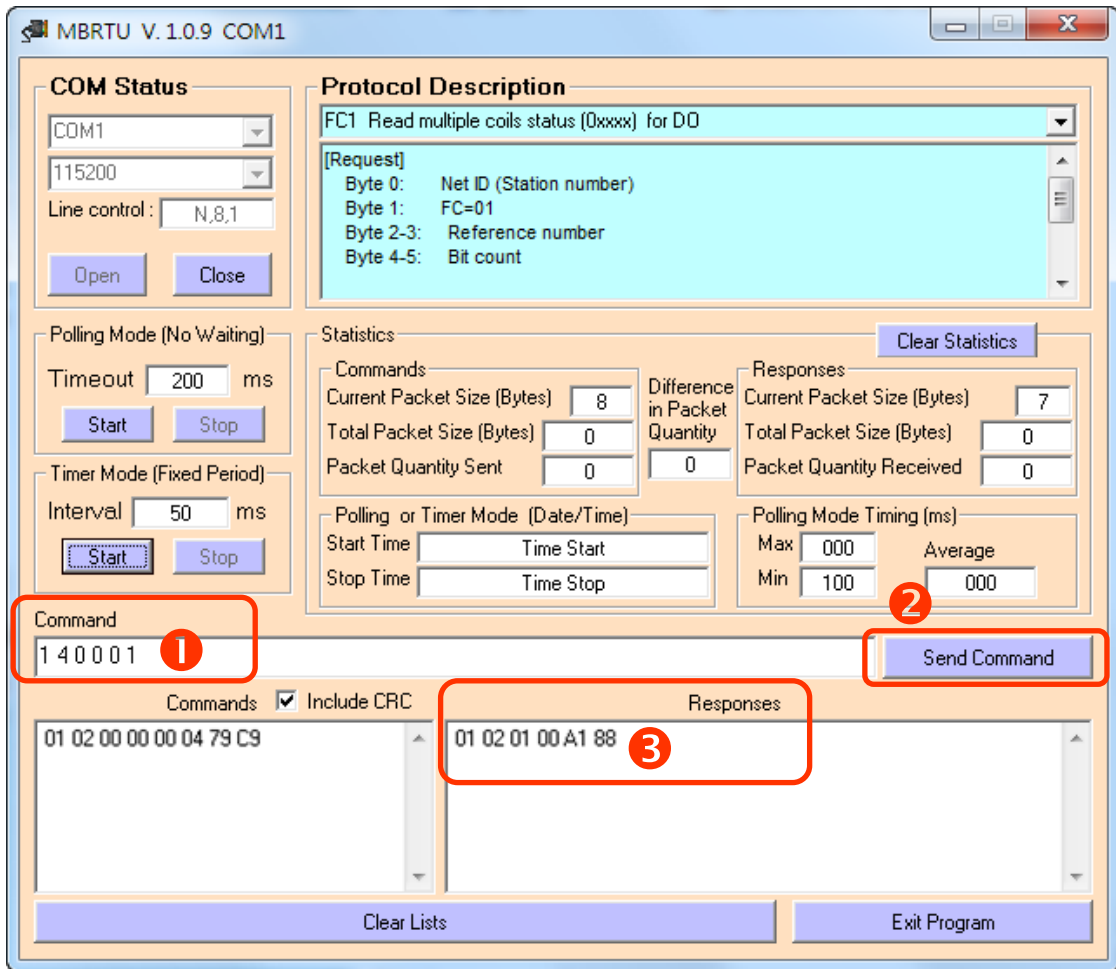

Figure 6-10

Notes:

1. The response depends on which Modbus is device connected.
2. The Baud Rate and Data Format values depend on the serial port settings configured for the web configuration described above.

6.4 TCP Client Mode Applications

In TCP Client Mode, the tGW-700/GW-2200 can actively establish a TCP connection to a specific Modbus TCP slave device. An example of how the complete system should operate is shown below:



Figure 6-11

The following are examples of pair-connection tests:

➤ **TCP Client Mode Settings:**

Model	Port Settings (default)		Pair-connection Settings		
	Baud Rate	Data Format	Application Mode	Remote Server IP	Remote TCP Port
tGW-700 GW-2200	115200	8, N, 1	Client	10.0.8.10	502
				IP address and TCP port for the tPET-P6 (Slave Device)	
tPET-P6 (Slave Device)	-	-	-	-	-

Step 1: Connecting to a network, a PC and a Power Supply

1. Confirm that the tGW-700/GW-2200 device is functioning correctly. For detailed information regarding how to install, configure and operate your tGW-700/GW-2200 series module, refer to [Chapter 3 “Getting Started for tGW-700/GW-2200 series using IPv4”](#), [Chapter 4 “Getting Started for tGW-700/GW-2200 series using IPv6”](#).
2. Connect both the tGW-700/GW-2200, the Slave Device (e.g. a tPET-P6, optional) and your computer to the same sub network or the same Ethernet Switch. For detailed information regarding RS-232/RS-422/485 wiring, refer to [Section 2.5 “Wiring Notes for RS-232/422/485 Interfaces”](#).

The wiring diagram is as follows:

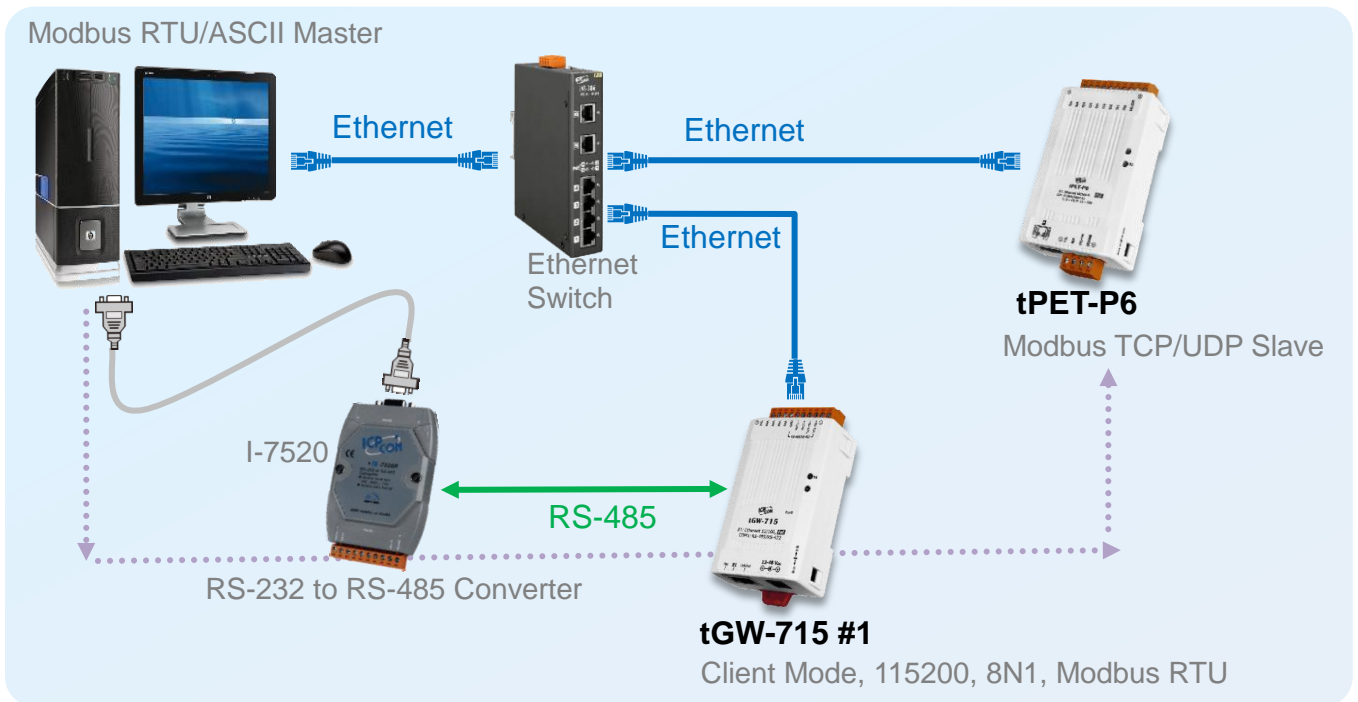

Figure 6-12

.....▶
Data request flow

Step 2: Configuring the Ethernet Settings

Contact your Network Administrator to obtain a correct and functioning network configuration (including the **IP Address, Mask and Gateway details**) for the tGW-700/GW-2200 module. Also refer to [Chapter 3 “Getting Started for tGW-700/GW-2200 series using IPv4”](#), [Chapter 4 “Getting Started for tGW-700/GW-2200 series using IPv6”](#) for more details.

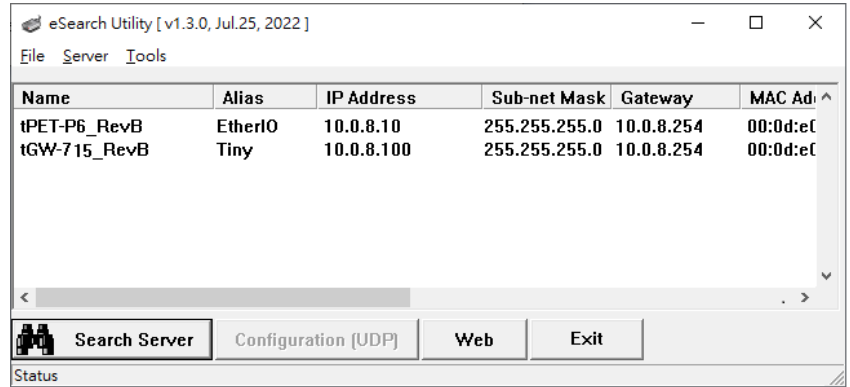

Figure 6-13

Step 3: Configuring Pair-connection (TCP Client Mode) for the tGW-700/GW-2200 module

1. Open the eSearch Utility to search for the tGW-700/GW-2200 modules connected to the network. Click the name of the first tGW-700/GW-2200 module to select it, and then click the **“Web”** button to launch a browser window to connect to the web server on the tGW-700/GW-2200 module. Alternatively, you can enter the URL for tGW-700/GW-2200 in the address bar of the browser.
2. When the login screen is displayed, enter the password in the Password field, and then click the **“Submit”** button to display the configuration page.

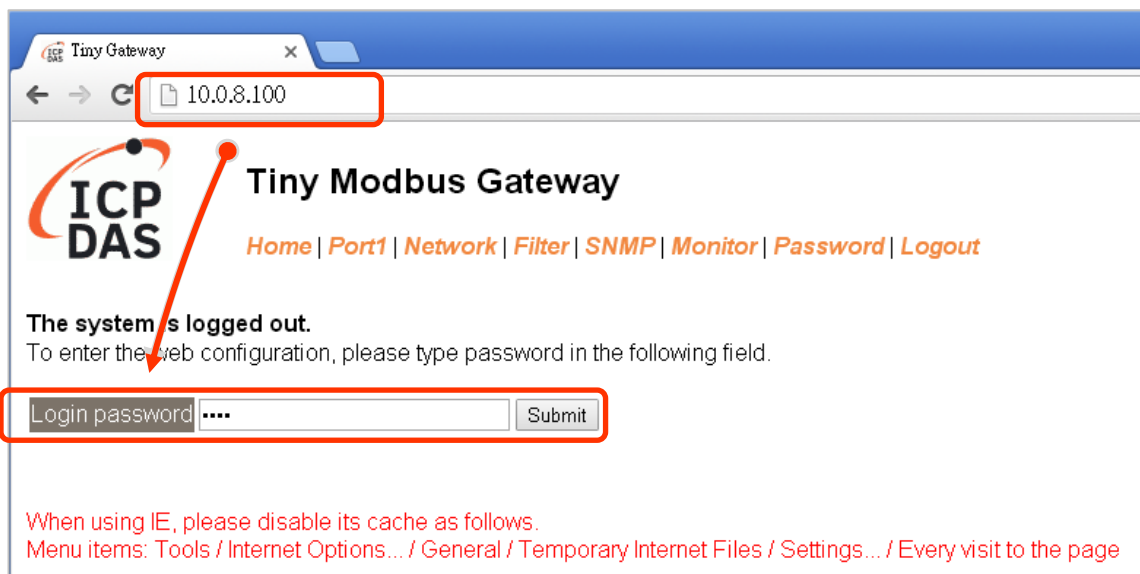

Figure 6-14

3. Click the “Port1” tab to display the Port1 Settings page.



Figure 6-15

4. Select the appropriate **Baud Rate**, **Data Format** and **Modbus Protocol** settings from the relevant drop down options. The following is an example: Baud Rate (bps) “115200”, Data Bits (bits) “8”, Parity “None”, Stop Bits (bits) “1” and Modbus Protocol “Modbus RTU”.

Port 1 Settings			
Port Settings	Current	Updated	Comment
Baud Rate	115200	115200 (select <input type="text"/>)	bps (bits/second)
Data Size	8	8 <input type="text"/>	bits/char
Parity	None	None <input type="text"/>	
Stop Bits	1	1 <input type="text"/>	
Flow Control	None	None <input type="text"/>	
Remove Errors	FE BE	<input type="checkbox"/> Parity Error <input checked="" type="checkbox"/> Framing Error <input checked="" type="checkbox"/> Break Error	Clear RX FIFO data when serial errors.
Modbus Settings	Current	Updated	Comment
Slave Timeout	300	300 <input type="text"/>	10 - 65000 ms (step 10), Default: 300. (Note)
Char Timeout	4	4 <input type="text"/>	4 - 15 bytes, Default: 4
Silent Time	0	0 <input type="text"/>	0 - 65000 ms (step 10), Default: 0
Protocol	Modbus RTU	Modbus RTU <input type="text"/>	

Figure 6-16

5. In the **Pair-connection Settings** area of the Port1 Settings page, check that the configuration details are the same as those shown below.

Field	Application Mode	Network Protocol	Remote Server IP	Remote TCP Port
Pair-Connection Settings	Client	TCP / IPv4	10.0.8.10	502
		Modbus Protocol, IP address and TCP port of the slave device (e.g., tPET-P6)		

6. Amend any details as required and then click the **“Submit”** button to complete the configuration.

Pair-Connection Settings (Master/Slave Mode)	Current	Updated	Comment
Application Mode	Client	Client ▾	Server=Slave, Client=Master
Network Protocol	TCP / IPv4	TCP / IPv4 ▾	
Remote Server IP	10.0.8.10	<input type="text" value="10.0.8.10"/>	For example : IPv4 = 10.0.8.100 IPv6 = fc00::1000
Remote TCP Port	502	<input type="text" value="502"/>	

Figure 6-17

Step 4: Testing the Pair-connection (TCP Client Mode) Functions

➤ For more detailed information regarding the testing procedure, refer to [Step 5 \(Figures 6-8 to 6-10\)](#) in the [Section 6.3 “Pair-connection Applications”](#).

7. Modbus Information

What is Modbus TCP/IP?

Modbus is a communication protocol developed by Modicon in 1979. You can also visit <http://www.modbus.org> to find more valuable information.

The Different versions of Modbus used today include Modbus RTU (based on serial communication interfaces such as RS485 and RS232), Modbus ASCII and Modbus TCP, which is the Modbus RTU protocol embedded into TCP packets.

Modbus TCP is an internet protocol. The protocol embeds a Modbus frame into a TCP frame so that a connection oriented approach is obtained, thereby making it reliable. The master queries the slave and the slave responds with the reply. The protocol is open and, hence, highly scalable.

7.1 Modbus Message Structure

Modbus devices communicate using a master-slave (client-server) technique in which only one device (the master/client) can initiate transactions (called queries). The other devices (slaves/servers) respond by supplying the requested data to the master, or by taking the action requested in the query.

A query from a master will consist of a slave address (or broadcast address), a function code defining the requested action, any required data, and an error checking field. A response from a slave consists of fields confirming the action taken, any data to be returned, and an error checking field.

Modbus/TCP Message Structure

Byte 00~05	Byte 06~11
6-byte header	RTU Data

Leading 6 bytes of Modbus/TCP protocol:

Byte 00	Byte 01	Byte 02	Byte 03	Byte 04	Byte 05
Transaction identifier		Protocol identifier		Length field (upper byte)	Length field (lower byte)

Transaction identifier: Assigned by Modbus/TCP master (client)

Protocol identifier: 0

Length field (upper byte): 0 (since all messages are smaller than 256)

Length field (lower byte): Number of following RTU data bytes

RTU Data Structure

Byte 06	Byte 07	Byte 08-09	Byte 10-11
Net ID (Station number)	Function Code	Data Field	
		Reference number (Address Mapping)	Number of points

➤ **Net ID (Station Number):** specifies the address of the receiver (Modbus/TCP slave).

The first byte in the message structure of Modbus is the receiver’s address. The valid addresses are in the range of 0 to 247. Address 0 is used for broadcast, while addresses 1 to 247 are given to individual Modbus devices.

➤ **Function Code:** specifies the message type.

The second byte in the frame structure of the Modbus RTU is the function code. The function code describes what the slave is required to do. Valid function codes are between 1 and 255. The slave uses the same function code as the request to answer it. Only when an error occurs in the system will the highest bit of the function code be set to ‘1’. Hence the master will know whether the message has been transmitted correctly or not.

Code	Function	Reference (Address)
01 (0x01)	Read the Status of the Coils (Readback DOs)	0xxxx
02 (0x02)	Read the Status of the Input(Reads DIs)	1xxxx
03 (0x03)	Read the Holding Registers (Readback AOs)	4xxxx
04 (0x04)	Read the Input Registers (Reads AIs)	3xxxx
05 (0x05)	Force a Single Coil (Writes DO)	0xxxx
06 (0x06)	Preset a Single Register (Writes AO)	4xxxx
15 (0x0F)	Force Multiple Coils (Writes DOs)	0xxxx
16 (0x10)	Preset Multiple Registers (Writes AOs)	4xxxx

➤ **Data Field:** is the data block.

Data is transmitted in 8-, 16- and 32-bit format. The data for 16-bit registers is transmitted in high-byte first format. For example: 0x0A0B ==> 0x0A, 0x0B. The data for 32-bit registers is transmitted as two 16-bit registers, and is low-word first. For example: 0x0A0B0C0D ==> 0x0C, 0x0D, 0x0A, 0x0B.

The data field of messages sent between a master and a slave contains additional information about the action to be taken by the master or any information requested by the slave. If the master does not require this information, the data field can be empty.

Reference (Address)	Description
0xxxx	<u>Read/Write Discrete Outputs or Coils.</u> A 0x reference address is used to output device data to a digital output channel.
1xxxx	<u>Read Discrete Inputs.</u> The ON/OFF status of a 1x reference address is controlled by the corresponding digital input channel.
3xxxx	<u>Read Input Registers.</u> A 3x reference register contains a 16-bit number received from an external source, e.g. an analog signal.
4xxxx	<u>Read/Write Output or Holding Registers.</u> A 4x register is used to store 16bits of numerical data (binary or decimal), or to send the data from the CPU to an output channel.

Note: For details regarding address mapping (Reference Number) depends on your slave device.

01(0x01) Read the Status of the Coils (Readback DOs)

This function code is used to read either the current status of the coils or the current digital output readback value.

[Request]

Byte	Description	Size	Value
00	Net ID (Station Number)	1 Byte	1 to 247
01	Function Code	1 Byte	0x01
02-03	Starting DO Address	2 Bytes	Refer to the Modbus address depends on your slave device for more details. Byte 02 = high byte Byte 03 = low byte
04-05	Number of Points (Channels)	2 Bytes	Byte 04 = high byte Byte 05 = low byte

[Response]

Byte	Description	Size	Value
00	Net ID (Station Number)	1 Byte	1 to 247
01	Function Code	1 Byte	0x01
02	Byte Count	1 Byte	Byte Count of the Response ($n = (Points+7)/8$)
03	Data	n Bytes	n= 1; Byte 03 = data bit 7 to 0 n= 2; Byte 04 = data bit 15 to 8 n= m; Byte m+2 = data bit (8m-1) to 8(m-1)

[Error Response]

Byte	Description	Size	Value
00	Net ID (Station Number)	1 Byte	1 to 247
01	Function Code	1 Byte	0x81
02	Exception Code	1 Byte	Refer to the Modbus Standard Specifications for more details

02(0x02) Read the Status of the Input (Read DIs)

This function code is used to read the current digital input value.

[Request]

Byte	Description	Size	Value
00	Net ID (Station Number)	1 Byte	1 to 247
01	Function Code	1 Byte	0x02
02-03	Starting DI Address	2 Bytes	Refer to the Modbus address depends on your slave device for more details. Byte 02 = high byte Byte 03 = low byte
04-05	Number of Points (Channels)	2 Bytes	Byte 04 = high byte Byte 05 = low byte

[Response]

Byte	Description	Size	Value
00	Net ID (Station Number)	1 Byte	1 to 247
01	Function Code	1 Byte	0x02
02	Byte Count	1 Byte	Byte Count of Response ($n = (\text{Points} + 7) / 8$)
03	Data	n Bytes	n= 1; Byte 03 = data bit 7 to 0 n= 2; Byte 04 = data bit 15 to 8 n= m; Byte m+2 = data bit (8m-1) to 8(m-1)

[Error Response]

Byte	Description	Size	Value
00	Net ID (Station Number)	1 Byte	1 to 247
01	Function Code	1 Byte	0x82
02	Exception Code	1 Byte	Refer to the Modbus Standard Specifications for more details

03(0x03) Read the Holding Registers (Readback AOs)

This function code is used to readback either the current values in the holding registers or the analog output value.

[Request]

Byte	Description	Size	Value
00	Net ID (Station Number)	1 Byte	1 to 247
01	Function Code	1 Byte	0x03
02-03	Starting AO Address	2 Bytes	Refer to the Modbus address depends on your slave device for more details. Byte 02 = high byte Byte 03 = low byte
04-05	Number of 16-bit Registers (Channels)	2 Bytes	Word Count Byte 04 = high byte Byte 05 = low byte

[Response]

Byte	Description	Size	Value
00	Net ID (Station Number)	1 Byte	1 to 247
01	Function Code	1 Byte	0x03
02	Byte Count	1 Byte	Byte Count of the Response (n=Points x 2 Bytes)
03~	Register Values	n Bytes	Register Values n= 2; Byte 03 = high byte Byte 04 = low byte n= m; Byte 03 = high byte Byte 04 = low byte Byte m+1 = high byte Byte m+2 = low byte

[Error Response]

Byte	Description	Size	Value
00	Net ID (Station Number)	1 Byte	1 to 247
01	Function Code	1 Byte	0x83
02	Exception Code	1 Byte	Refer to the Modbus Standard Specifications for more details

04(0x04) Read the Input Registers (Read AIs)

This function code is used to read either the input registers or the current analog input value.

[Request]

Byte	Description	Size	Value
00	Net ID (Station Number)	1 Byte	1 to 247
01	Function Code	1 Byte	0x04
02-03	Starting AI Address	2 Bytes	Refer to the Modbus address depends on your slave device for more details. Byte 02 = high byte Byte 03 = low byte
04-05	Number of 16-bit Registers (Channels)	2 Bytes	Word Count Byte 04 = high byte Byte 05 = low byte

[Response]

Byte	Description	Size	Value
00	Net ID (Station Number)	1 Byte	1 to 247
01	Function Code	1 Byte	0x04
02	Byte Count	1 Byte	Byte Count of the Response (n=Points x 2 Bytes)
03~	Register Values	n Bytes	Register Values n= 2; Byte 03 = high byte Byte 04 = low byte n= m; Byte 03 = high byte Byte 04 = low byte Byte m+1 = high byte Byte m+2 = low byte

[Error Response]

Byte	Description	Size	Value
00	Net ID (Station Number)	1 Byte	1 to 247
01	Function Code	1 Byte	0x84
02	Exception Code	1 Byte	Refer to the Modbus Standard Specifications for more details.

05(0x05) Force a Single Coil (Write DO)

This function code is used to set the status of a single coil or a single digital output value.

[Request]

Byte	Description	Size	Value
00	Net ID (Station Number)	1 Byte	1 to 247
01	Function Code	1 Byte	0x05
02-03	DO Address	2 Bytes	Refer to the Modbus address depends on your slave device for more details. Byte 02 = high byte Byte 03 = low byte
04-05	Output Value	2 Bytes	0xFF 00 sets the output to ON. 0x00 00 sets the output to OFF. All other values are invalid and will not affect the coil. Byte 04 = high byte Byte 05 = low byte

[Response]

Byte	Description	Size	Value
00	Net ID (Station Number)	1 Byte	1 to 247
01	Function Code	1 Byte	0x05
02-03	DO Address	2 Bytes	The value is the same as Bytes 02-03 of the Request
04-05	Output Value	2 Bytes	The value is the same as Bytes 04-05 of the Request

[Error Response]

Byte	Description	Size	Value
00	Net ID (Station Number)	1 Byte	1 to 247
01	Function Code	1 Byte	0x85
02	Exception Code	1 Byte	Refer to the Modbus Standard Specifications for more details.

06(0x06) Preset a Single Register (Write AO)

This function code is used to set a specific holding register to store the configuration values.

[Request]

Byte	Description	Size	Value
00	Net ID (Station Number)	1 Byte	1 to 247
01	Function Code	1 Byte	0x06
02-03	AO Address	2 Bytes	Refer to the Modbus address depends on your slave device for more details. Byte 02 = high byte Byte 03 = low byte
04-05	Register Value	2 Bytes	Register Value Byte 04 = high byte Byte 05 = low byte

[Response]

Byte	Description	Size	Value
00	Net ID (Station Number)	1 Byte	1 to 247
01	Function Code	1 Byte	0x06
02-03	AO Address	2 Bytes	The value is the same as Bytes 02-03 of the Request
04-05	Register Value	2 Bytes	The value is the same as Bytes 04-05 of the Request

[Error Response]

Byte	Description	Size	Value
00	Net ID (Station Number)	1 Byte	1 to 247
01	Function Code	1 Byte	0x86
02	Exception Code	1 Byte	Refer to the Modbus Standard Specifications for more details.

15(0x0F) Force Multiple Coils (Write DOs)

This function code is used to set multiple coils status or write multiple digital output values.

[Request]

Byte	Description	Size	Value
00	Net ID (Station Number)	1 Byte	1 to 247
01	Function Code	1 Byte	0x0F
02-03	Starting DO Address	2 Bytes	Refer to the Modbus address depends on your slave device for more details. Byte 02 = high byte Byte 03 = low byte
04-05	Number of Output Channels (Points)	2 Bytes	Byte 04 = high byte Byte 05 = low byte
06	Byte count	1 Byte	$n = (Points + 7) / 8$
07	Output value	n Bytes	A bit corresponds to a channel. A value of 1 for a bit denotes that the channel is ON, while a value of 0 denotes that the channel is OFF. n= 1; Byte 07 = data bit 7 to 0 n= 2; Byte 08 = data bit 15 to 8 n= m; Byte m+6 = data bit (8m-1)to 8 (m-1)

[Response]

Byte	Description	Size	Value
00	Net ID (Station Number)	1 Byte	1 to 247
01	Function Code	1 Byte	0x0F
02-03	Starting DO Address	2 Bytes	The value is the same as Bytes 02-03 of the Request
04-05	Number of Output Channels (Points)	2Bytes	The value is the same as Bytes 04-05 of the Request

[Error Response]

Byte	Description	Size	Value
00	Net ID (Station Number)	1 Byte	1to 247
01	Function Code	1 Byte	0x8F
02	Exception Code	1 Byte	Refer to the Modbus Standard Specifications for more details.

16(0x10) Preset Multiple Registers (Write AOs)

This function code is used to set multiple holding registers that are used to store the configuration values.

[Request]

Byte	Description	Size	Value
00	Net ID (Station Number)	1 Byte	1 to 247
01	Function Code	1 Byte	0x10
02-03	Starting AO Address	2 Bytes	Refer to the Modbus address depends on your slave device for more details. Byte 02 = high byte Byte 03 = low byte
04-05	Number of 16-bit Registers (Channels)	2 Bytes	Word Count. Byte 04 = high byte Byte 05 = low byte
06	Byte Count	1 Byte	n =Points x 2 Bytes
07	Register Values	n Bytes	Register Values. n= 2; Byte 03 = high byte Byte 04 = low byte n= m; Byte 03 = high byte Byte 04 = low byte Byte m+1 = high byte Byte m+2 = low byte

[Response]

Byte	Description	Size	Value
00	Net ID (Station Number)	1 Byte	1 to 247
01	Function Code	1 Byte	0x10
02-03	Starting AO Address	2 Bytes	The value is the same as Bytes 02-03 of the Request
04-05	Number of 16-bit Registers (Channels)	2 Bytes	The value is the same as Bytes 04-05 of the Request

[Error Response]

Byte	Description	Size	Value
00	Net ID (Station Number)	1 Byte	1 to 247
01	Function Code	1 Byte	0x90
02	Exception Code	1 Byte	Refer to the Modbus Standard Specifications for more details.

7.2 Exception Codes

If an exception occurs during Modbus communication, the slave device will return an Exception Code in the response message. The following is an explanation of the Exception Codes:

➤ Exception Codes:

Code	Name and Description
0x01	ILLEGAL FUNCTION
	Indicates that the function code received in the query is not an allowable action for the slave. If not an allowable action for the slave. If a Poll Program Complete command was issued, this code indicates that no program function preceded it.
0x02	ILLEGAL DATA ADDRESS
	Indicates that the data address received in the query is not an allowable address for the slave.
0x03	ILLEGAL DATA VALUE
	Indicates that a value contained in the query data field is not an allowable value for the slave.
0x04	SLAVE DEVICE FAILURE
	Indicates that an unrecoverable error occurred while the slave was attempting to perform the requested action.
0x05	ACKNOWLEDGE
	Indicates that the slave has accepted the request and is processing it, but it will take an extended period of time to do so. This response is returned to prevent a timeout error from occurring in the master. The master can issue a Poll Program Complete message later to determine whether the processing is complete.
0x06	SLAVE DEVICE BUSY
	Indicates that the slave is engaged in processing a long-duration program command. The master should retransmit the message later when the slave is free.
0x07	NEGATIVE ACKNOWLEDGE
	Indicates that the extended file area failed to pass a consistency check, and the slave cannot perform the program function received in the query. This code is returned when a programming request using function code 13 or 14 decimal was unsuccessful. The master should request diagnostic or error information from the slave.
0x08	MEMORY PARITY ERROR
	Indicates that the slave attempted to read extended memory, but detected a parity error in the memory. The master can retransmit the request, but maintenance may be required on the slave device.

➤ **Defined Exception Codes for tGW-700/GW-2200:**

Code	Name and Description
0x0B	GATEWAY TARGET DEVICE FAILED TO RESPOND
	Timeout. The slave device does not respond within the timeout value, the tGW-700/GW-2200 will return this code.
0x4B	GATEWAY TARGET DATA FAILED TO RESPOND
	Timeout. The slave device is still sending data when timed out, the tGW-700/GW-2200 will return this code. Please use larger Slave Timeout value for the serial port of the tGW-700/GW-2200 module.
0x41	MODBUS PROTOCOL FORMAT ERROR
	The tGW-700/GW-2200 will return this code when slave response is invalid Modbus message.
0x42	WRONG DATA LENGTH
	The tGW-700/GW-2200 will return this code when tGW-700/GW-2200 received wrong data length. Please use larger Slave Timeout value for the serial port of the tGW-700/GW-2200 module.
0x43	CRC ERROR
	The tGW-700/GW-2200 will return this code when the CRC of the slave response is wrong.

Appendix A: Troubleshooting

A1. How do I restore the web password for the module to the factory default password?

The instructions below outline the procedure for resetting the web password to the factory default value. **Note: Be aware that ALL settings will be restored to the factory default values after the module is reset.**

Step 1 Locate the Init/Run switch that can be found on the right-hand side of the tGW-700/GW-2200 module and set it to the "Init" position. Reboot the module to load factory default settings including default web password.

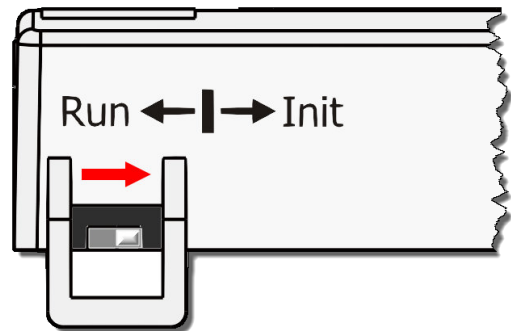

Step 2 Execute the eSearch Utility to search for any tGW-700/GW-2200 modules connected to the network. Verify that the tGW-700/GW-2200 has been reset to the original factory default settings. For example, the module should be shown as having the default IP address, which is 192.168.255.1.

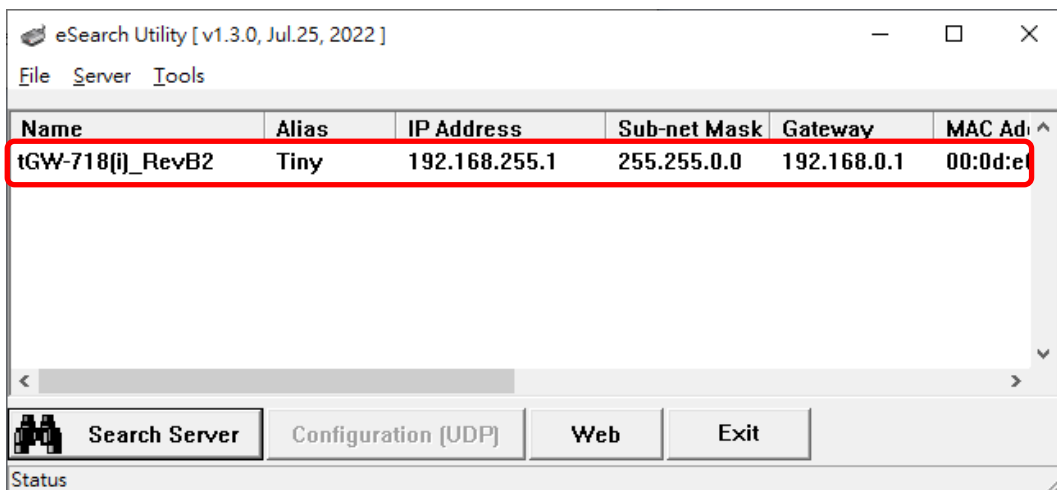

Step 3 Double-click the name of the module to open the Configure Server (UDP) dialog box, and modify the basic settings as necessary, e.g., the IP, Mask and Gateway addresses, and then click the "OK" button to **save the new settings**.

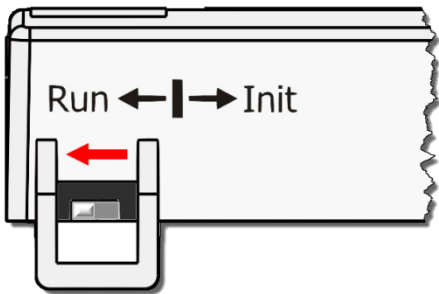
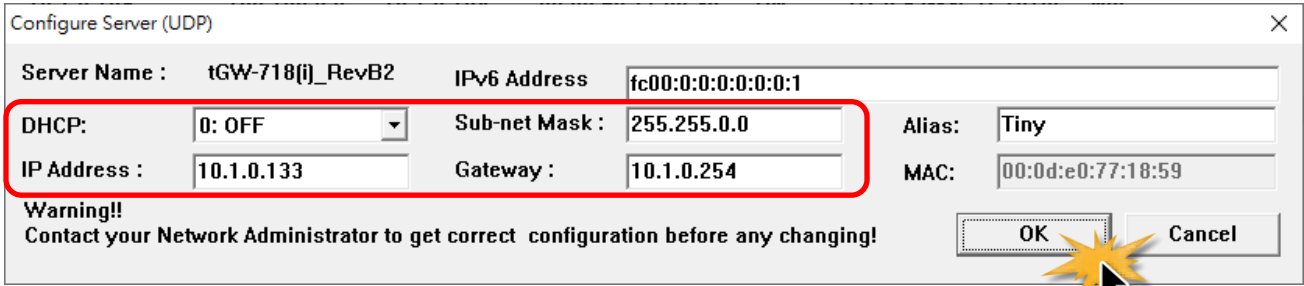

Step 4 Reset the Init/Run switch on the tGW-700/GW-2200 module to the "Run" position and reboot the module.

Step 5 Log in to the tGW-700/GW-2200 web server.

It requires you to change the password as the first login. Enter "admin" in the **Current password** field, and enter your new password in the **New password** and **Confirm new password** fields, then click the "Submit" button.

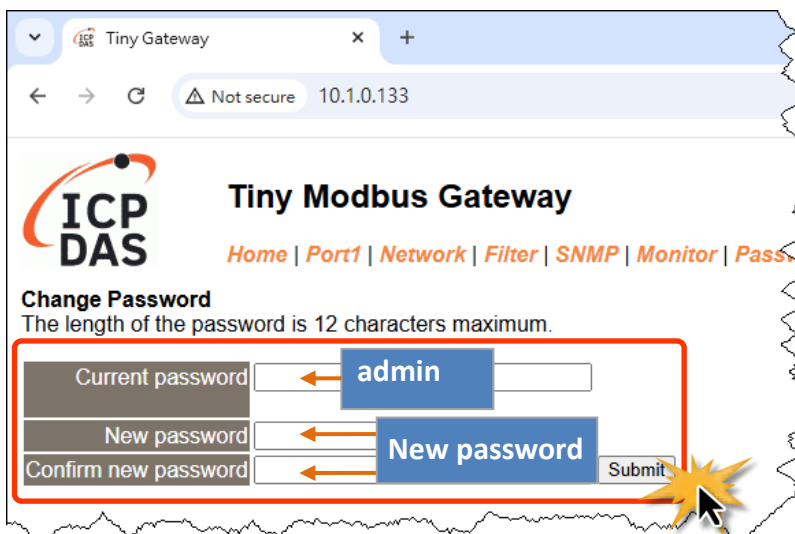

Appendix B: Glossary

1. ARP (Address Resolution Protocol)

The Address Resolution Protocol (ARP) is a telecommunication protocol that is used to convert an IP address to a physical address, such as an Ethernet address.

Consider two machines A and B that share the same physical network. Each has an assigned IP address IP_A and IP_B , and a MAC address, MAC_A and MAC_B . The goal is to devise a low-level software application that hides the MAC addresses and allows higher-level programs to work only with the IP addresses. Ultimately, however, communication must be carried out by the physical networks using whatever MAC address scheme the hardware supplies.

Suppose machine A wants to send a packet to machine B across a physical network to which they are both attached, but A only has the Internet address for B, IP_B . The question arises: how does A map that address to the MAC address for B, MAC_B ?

ARP provides a method of dynamically mapping 32-bit IP address to the corresponding 48-bit MAC address. The term dynamic is used since the mapping is performed automatically and is normally not a concern for either the application user or the system administrator.

2. Clients and Servers

The client-server paradigm uses the direction of initiation to categorize whether a program is a client or server. In general, an application that initiates peer-to-peer communication is called a client. End users usually invoke client programs when they use network services.

By comparison, a server is any program that waits for incoming requests from a client program. The server receives a request from a client, performs the necessary action and returns the result to the client.

3. Ethernet

The term Ethernet generally refers to a standard published in 1982 by Digital Equipment Corp., Intel Corp. and Xerox Corp. Ethernet is the most popular physical layer Local Area Network (LAN) technology in use today.

4. Firmware

Firmware is an embedded software program or set of instructions programmed on a device that provides the necessary instructions for how the device communicated with other computer hardware, and is located or stored in a semi-permanent storage area, e.g., ROM, EEPROM, or Flash memory. Firmware can often be updated by downloading a file from the manufacturer's web site or FTP.

5. Gateway

Computers that interconnect two networks and pass packets from one to the other are called Internet Gateways or Internet Routers. Gateways route packets that are based on the destination network, rather than the destination host.

6. ICMP (Internet Control Message Protocol)

ICMP provides a method of communicating between the Internet Protocol software on one machine and the corresponding software on another. It allows a gateway to send error or control messages to other gateways, or allows a host to diagnose problems with the network communication.

7. Internet

Physically, the Internet is a collection of packet switching networks interconnected by gateways that together with the TCP/IP protocol, allows them to perform logically as a single, large and virtual network. The Internet recognizes hosts using 32-bit IP address.

8. IP (Internet Protocol) Address

Each interface on the Internet must have a unique IP address (also called an Internet address). These addresses are 32-bit numbers, and are normally written as four decimal numbers, one for each byte of the address for example “192.168.41.1”. This is called dotted-decimal notation.

9. MAC (Media Access Control) Address

To allow a computer to determine which packets are meant for it, each device attached to an Ethernet network is assigned a 48-bit integer known as its MAC address (also called the Ethernet address, the hardware address or the physical address). A MAC address is normally written as eight hexadecimal numbers, for example “00:71:88: AF: 12:3e:0f:01”. Ethernet hardware manufacturers purchase blocks of MAC addresses and assign them in sequence as they manufacture Ethernet interface hardware. Thus, no two hardware interfaces can have the same MAC address.

10. Packet

A packet is the unit of data sent across a physical network. It consists of a series of bits containing data and control information, including the source and the destination node (host) address, and is formatted for transmission from one node to another.

11. Ping

Ping is a network administration utility used to test the whether a host on an Internet network is active, and to measure the round-trip time for messages sent from the originating host to a destination computer. Ping operates by sending an ICMP echo request message to a host, expecting an ICMP echo reply to be returned. Normally, if a host cannot be pinged, Telnet or FTP cannot be used to connect to the host. Conversely, if Telnet or FTP cannot be used to connect to a host, Ping is often the starting point to determine the nature of the problem.

12. RARP (Reverse Address Resolution Protocol)

RARP provides a method of dynamically mapping 48-bit MAC address to the corresponding 32-bit IP address. RARP has now been replaced by the Bootstrap Protocol (BOOTP) and the modern Dynamic Host Configuration Protocol (DHCP).

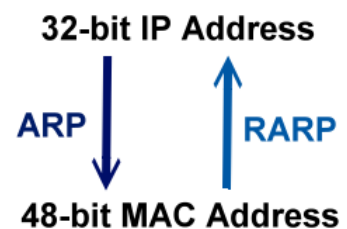

13. Socket

Each TCP segment contains a source and destination port number that can be used to identify the sending and receiving application. These two values, along with the source and destination IP addresses in the IP header, uniquely identify each connection. The combination of an IP address and a port number is called a socket.

14. Subnet Mask

A Subnet mask, often simply called the “Mask”, is a 32-bit number that masks an IP address, and divides the IP address into the network address and the host address. Given its own IP address and its subnet mask, a host can determine whether a TCP/IP packet is destined for a host that is (1) on its own subnet, or (2) on a different network. If (1), the packet will be delivered directly; otherwise it, will be delivered via a gateway or a router.

15. TCP (Transmission Control Protocol)

TCP is a set of rules used in combination with the Internet Protocol to send data in the form of message units between computers over the Internet. TCP provides a reliable flow of data between two hosts and is associated with tasks such as dividing the data passed to it from an application into appropriately sized chunks for the network layer below, acknowledging received packets, setting timeouts to make certain that the other end acknowledges packets that are sent, and so on.

16. TCP/IP

The Transmission Control Protocol (TCP) and the Internet Protocol (IP) are standard network protocols that are almost always implemented and used together in a formation are known as TCP/IP. TCP/IP can be used to communicate across any set of interconnected networks.

17. UDP (User Datagram Protocol)

UDP is an internet protocol that provides a much simpler service to the application layer as it only sends packets of data from one host to another, but there is no guarantee that the packets will reach the destination host. UDP is suitable for purposes where error checking and correction is either not necessary or is performed in the application.

Appendix C: Actual Baud Rate Measurement

Ideal Baud Rate (bps)	Actual Baud Rate (bps)	Error
300	298.48	0.51%
600	597.04	0.49%
1200	1197.6	0.20%
2400	2395.2	0.20%
4800	4790.4	0.20%
9600	9568.0	0.33%
14400	14392	0.05%
19200	19136	0.33%
38400	38464	0.17%
57600	57552	0.08%
115200	114960	0.21%
128000	128240	0.18%
230400	229920	0.21%
250000	250000	0.00%
256000	256400	0.15%
460800	459760	0.22%
921600	921600	0.00%

Note:

Recommended max baud rate is 115200 bps or below.

Because the loading of the module, we don't guarantee a proper operation if using a larger baud rate (over 115200 bps).

Appendix D: Revision History

This chapter provides revision history information to this document.

The table below shows the revision history.

Revision	Date	Description
1.0	Oct. 2010	Initial issue
1.1	Dec. 2010	Added the software and hardware information about the tGW-712/722/732/715/725/735/718.
1.3	Jan. 2011	Added the software and hardware information about the tGW-724/734.
1.7	Mar.2013	Added Chapter Appendix: Exception Codes.
1.9.1	Aug. 2014	Added Chapter Appendix: Actual Baud Rate Measurement.
1.9.2	Nov. 2014	Added the software and hardware information about the tGW-715i.
2.0	Dec. 2016	Added the software and hardware information about the tGW-712i/722i/732i/715i/725i/735i/718i/724i/734i.
2.1	Aug.2017	<ol style="list-style-type: none"> 1. Added Chapter Appendix A: Troubleshooting. 2. Added Chapter Appendix E: Revision History.
2.2	Nov.2017	Added the software and hardware information about the tGW-718i-D. Remove the package CD
2.2.1	Aug.2018	Update the dimensions of tGW-718i-D in the Sec 2.3.
2.3	Jun.2020	Added the software and hardware information about the GW-2200 series.
2.6	Oct.2020	Added the IPv6 features and tGW-700-T series information.
2.7	Jul. 2023	<ol style="list-style-type: none"> 1. Added Section 5.6. SNMP Page 2. Added information for changing the password on first login in Sections 3.4 and 4.4. 3. Modified the steps of IP Filter settings in Section 5.5
2.8	Sep. 2025	<ol style="list-style-type: none"> 1. Updated user interface information.