



## GW-7472

EtherNet/IP to Modbus RTU/TCP Gateway

### Features

- Tiny form-factor and low power consumption
- Ethernet Protocol: EtherNet/IP Adapter
- Modbus Protocol: Modbus RTU Master/Modbus TCP Client
- Maximum support 30 Modbus RTU commands
- Maximum support 10 Modbus TCP Servers
- Support 8 Modbus TCP commands for each TCP servers
- Maximum EtherNet/IP Input/Output data size: 500 bytes



### Introduction

The GW-7472 (EtherNet/IP adapter to Modbus RTU Master/TCP Client Gateway) is helpful for data-exchanging between the Modbus RTU/TCP network, and the EtherNet/IP network. It reads the register data from the Modbus RTU slaves as well as Modbus TCP servers and publishes these data to the input register data of the EtherNet/IP scanner. The output data transmitted by the EtherNet/IP scanner are updated to the register data of Modbus RTU slaves/TCP servers via the GW-7472. Through the GW-7472, all of the Modbus slaves/servers can be regard as one EtherNet/IP adapter.

### Utility Features



Network parameters configuration

- UART parameters configuration
- Modbus devices configuration
- Auto search GW-7472 device
- Easy test to transmit/receive EtherNet/IP data

### Internal I/O Structure

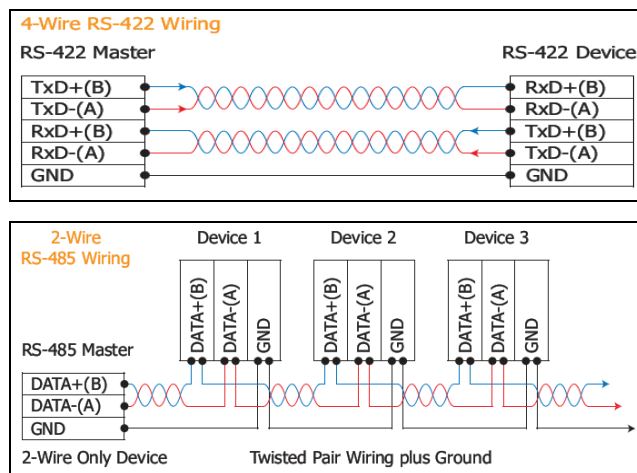

### Dimensions (Units: mm)

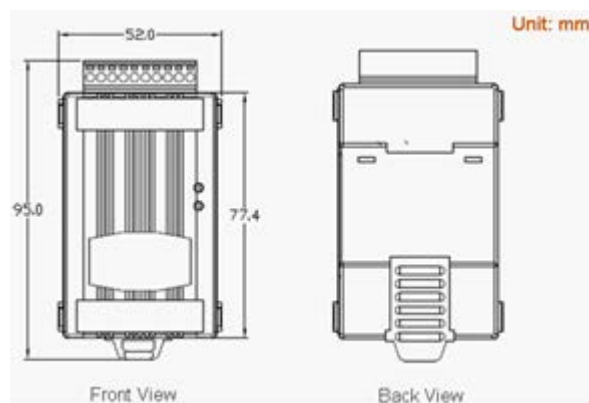

## Specifications

Hardware	
CPU	32-bit MCU
UART Interface	
COM 1	2-wire RS-485 4-wire RS-422
COM 1 Connector	10-Pin Removable Terminal Block x 1
Protocol	Modbus RTU master
Ethernet Interface	
Ethernet	10/100 Base-TX, 8-pin RJ-45 x 1, (Auto-negotiating, Auto-MDI/MDIX, LED indicator) PoE (IEEE 802.3af, Class 1)
Protocol	EtherNet/IP adapter and Modbus TCP client
Power	
Power supply	PoE: IEEE 802.3af, Class 1 DC jack: +12 ~ 48 VDC
Power Consumption	0.05 A @ 24 VDC
Mechanism	
Dimensions	52mm x 95mm x 27mm (W x L x H)
Mounting	DIN-Rail
Flammability	Fire Retardant Materials (UL94-V0 Level)
Environment	
Operating Temperature	-25 ~ 75 °C
Storage Temperature	-30 ~ 80 °C
Humidity	10 ~ 90% RH, non-condensing

## Application



## Ordering Information

GW-7472 CR	EtherNet/IP to Modbus RTU/TCP gateway with PoE and one RS-422/485 (RoHS)
------------	--------------------------------------------------------------------------