

DL-10

User Manual



RS-485 Remote Temperature and Humidity

English Ver. 1.4, May. 2024

WARRANTY

All products manufactured by ICP DAS are warranted against defective materials for a period of one year from the date of delivery to the original purchaser.

WARNING

ICP DAS assumes no liability for damages consequent to the use of this product. ICP DAS reserves the right to change this manual at any time without notice. The information furnished by ICP DAS is believed to be accurate and reliable. However, no responsibility is assumed by ICP DAS for its use, nor for any infringements of patents or other rights of third parties resulting from its use.

COPYRIGHT

Copyright © 2024 by ICP DAS. All rights are reserved.

TRADEMARK

Names are used for identification only and may be registered trademarks of their respective companies.

CONTACT US

If you have any questions, please feel free to contact us via email at: service@icpdas.com, service.icpdas@gmail.com

ICP DAS CO., LTD. 

service@icpdas.com 

<http://www.icpdas.com> 



TABLE OF CONTENTS

- 1. INTRODUCTION 3**
 - 1.1 PACKAGE LIST 3

- 2. HARDWARE INFORMATION 4**
 - 2.1 APPEARANCE & PIN ASSIGNMENTS 4
 - 2.2 SPECIFICATION 5
 - 2.3 DIMENSIONS..... 6
 - 2.4 FACTORY DEFAULT SETTINGS..... 6

- 3. GETTING STARTED 7**
 - 3.1 CONNECTING THE POWER AND THE HOST PC..... 7
 - 3.2 INSTALLING SOFTWARE ON YOUR PC 8
 - 3.3 SEARCH MODULE 8
 - How to solve when the DCON Utility cannot find the DL-10 module?..... 12*
 - 3.4 CONFIGURING MODULE..... 13
 - Configuration 14*
 - AI (Humidity & Temperature) 15*

- 4. MODBUS REGISTER TABLE (BASED0) 16**
 - DISCRETE INPUTS (1XXXX) 16
 - INPUT REGISTER (3XXXX)..... 16
 - HOLDING REGISTER (4XXXX) 17

- APPENDIX: REVISION HISTORY 18**

1. Introduction

The DL-10 is a RS-485 remote temperature and humidity module that gives you real time temperature and humidity information at the same time. It contains an RS-485 communication interface and an sensor for measuring temperature and humidity. The DL-10 module supports Modbus RTU communication protocol for getting measured temperature and humidity values. DCON Utility Pro provides easy and convenient interfaces for users to configure the module. Based on an amazing tiny form-factor, the DL-10 achieves the maximum space savings that allows it to be easily installed anywhere.

1.1 Package List

The shipping package includes the following items:



DL-10



Quick Start

NOTE

If any of these items is missing or damaged, please contact your local distributor for more information. Keep the shipping materials and overall package in case you want to ship the module back in the future.

More Information

- DL-10 Product Page:

<https://www.icpdas.com/en/product/DL-10>

<https://www.icpdas.com/en/product/DL-10-BK>

- Documentation:

http://ftp.icpdas.com/pub/cd/usbcd/napdos/dl_100/

- Free Development Software – DCON Utility Pro:

http://www.icpdas.com/root/product/solutions/software/utilities/dcon_utility_pro.html

2. Hardware Information

2.1 Appearance & Pin Assignments

The front panel and Rear panel of the DL-10 module contain the Temperature and Humidity sensor, init switch, power and RS-485 connector and pin assignments.

Front Panel

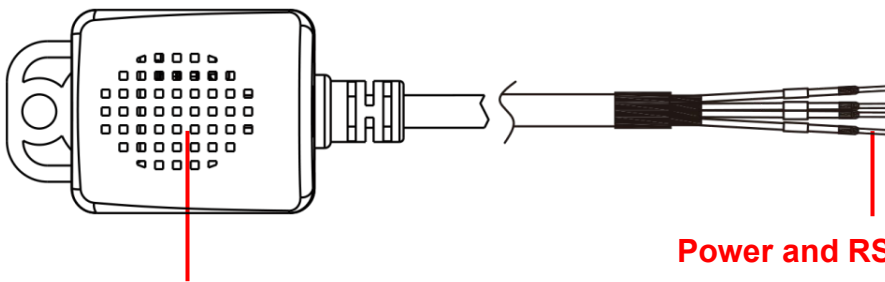

**Temperature and Humidity
Sensor**

Power and RS-485 Connector

CONN	COLOR	Pin Assignment
1	White	D-
2	Red	Vcc
3	Black	GND
4	Green	D+

Rear Panel

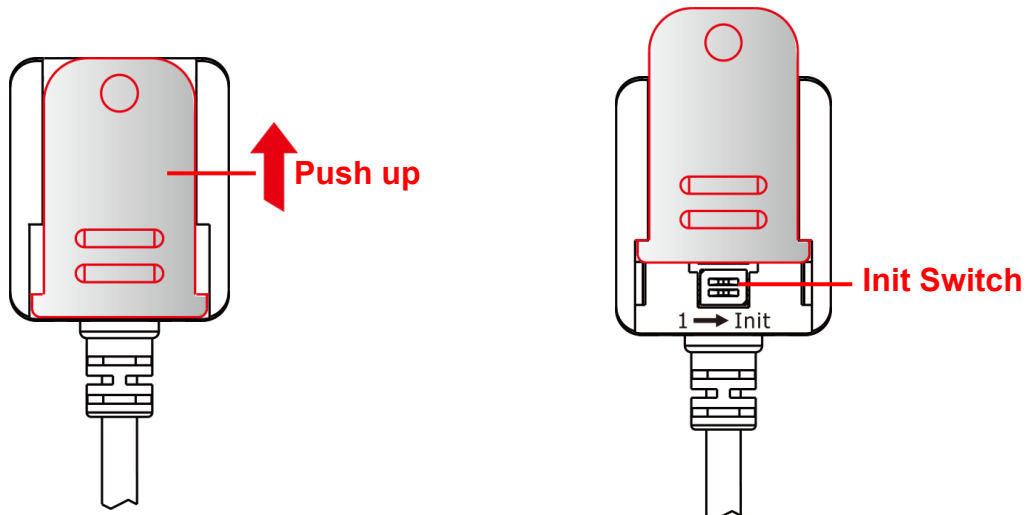

2.2 Specification

Temperature Sensor	
Measuring Range	-25 ~ +75 °C (-13 ~ +167 °F)
Resolution	0.1 °C
Accuracy	Typical: ± 0.4 °C @ 0 ~ 60 °C; refer to Figure 2
Precision	± 0.1% RH
Humidity Sensor	
Measuring Range	0 ~ 95% RH
Resolution	0.1% RH
Accuracy	Typical: ± 3% RH @ 20 ~ 80 % RH; refer to Figure 1
Precision	± 0.1% RH
Communication	
Interface	RS-485; non-isolated
Baudrate	1200 ~ 115200 bps
Data Format	N, 8, 1
Protocol	Modbus RTU
Max. Modules on same bus	32
Power	
Input Range	+10 ~ +30 V _{DC}
Power Consumption	0.05 W
Mechanical	
Dimensions (W x L x H)	25 mm x 20.2 mm x 30 mm
Installation	DIN-Rail; Wall Mount
Environment	
Operating Temperature	-25 ~ +75 °C
Storage Temperature	-30 ~ +80 °C
Ambient Relative Humidity	0 ~ 95% RH, Non-condensing

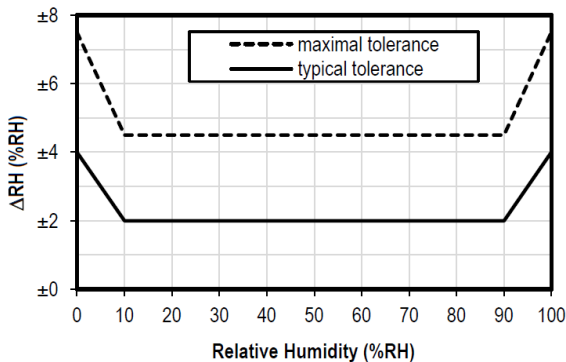

Figure 1 Tolerance of RH at 25°C for sensor.

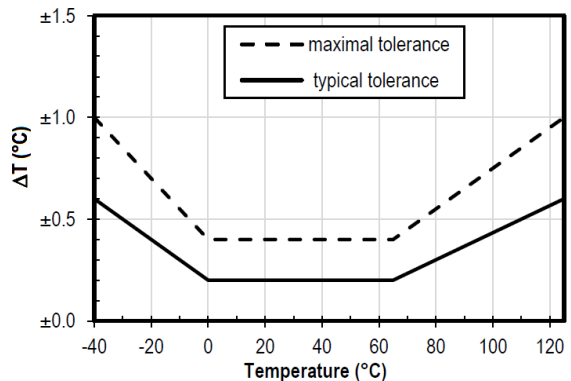
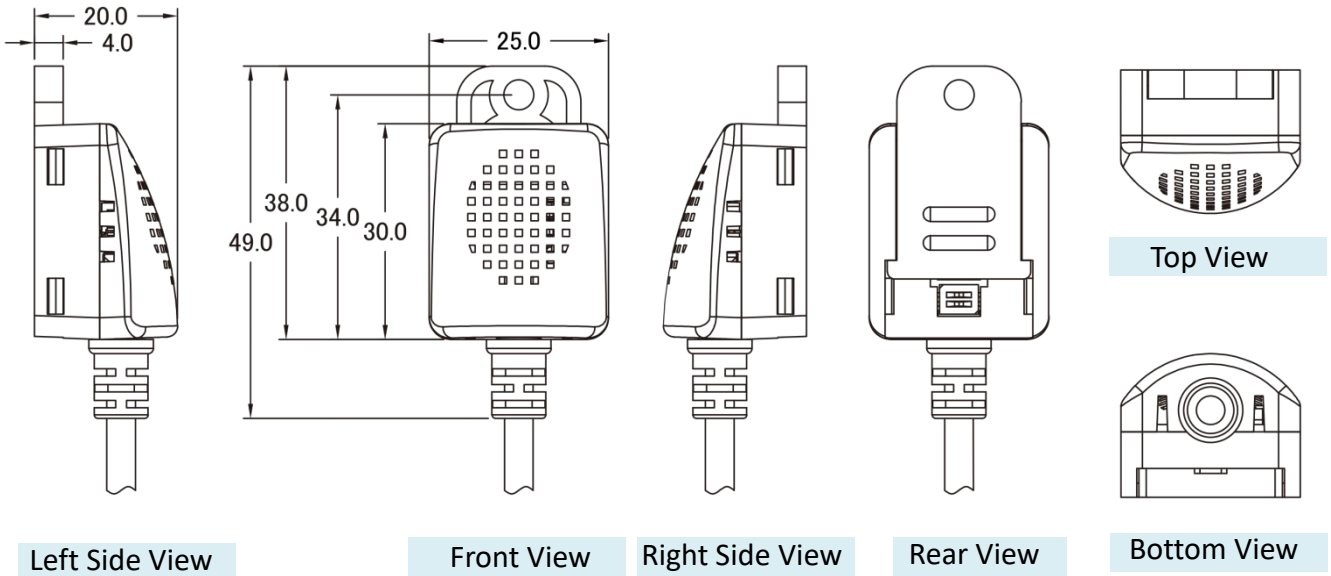

Figure 2 Temperature accuracy of the sensor.

2.3 Dimensions

The following diagrams provide the dimensions of the DL-10 module and can be used as a reference when defining the specifications for any custom enclosures. All dimensions are in millimeters.



2.4 Factory Default Settings

The following is an overview of the factory default settings:

Item	Default	Item	Default
Device ID	1	Data Format	N, 8, 1
Baud Rate	115200 bps		Parity: None
Protocol	Modbus RTU		Data Size: 8
			Stop Bits: 1

3. Getting Started

This chapter provides a basic overview of how to configure and operate your DL-10 module.

3.1 Connecting the Power and the Host PC

Prepare for device

- ☑ RS-232 to RS-485 Converter: tM-7520U (optional)
- ☑ Exterior power supply device: MDR-20-24 (optional)

Wiring

1 Connect both the DL-10 module and the Host PC via the tM-7520U.

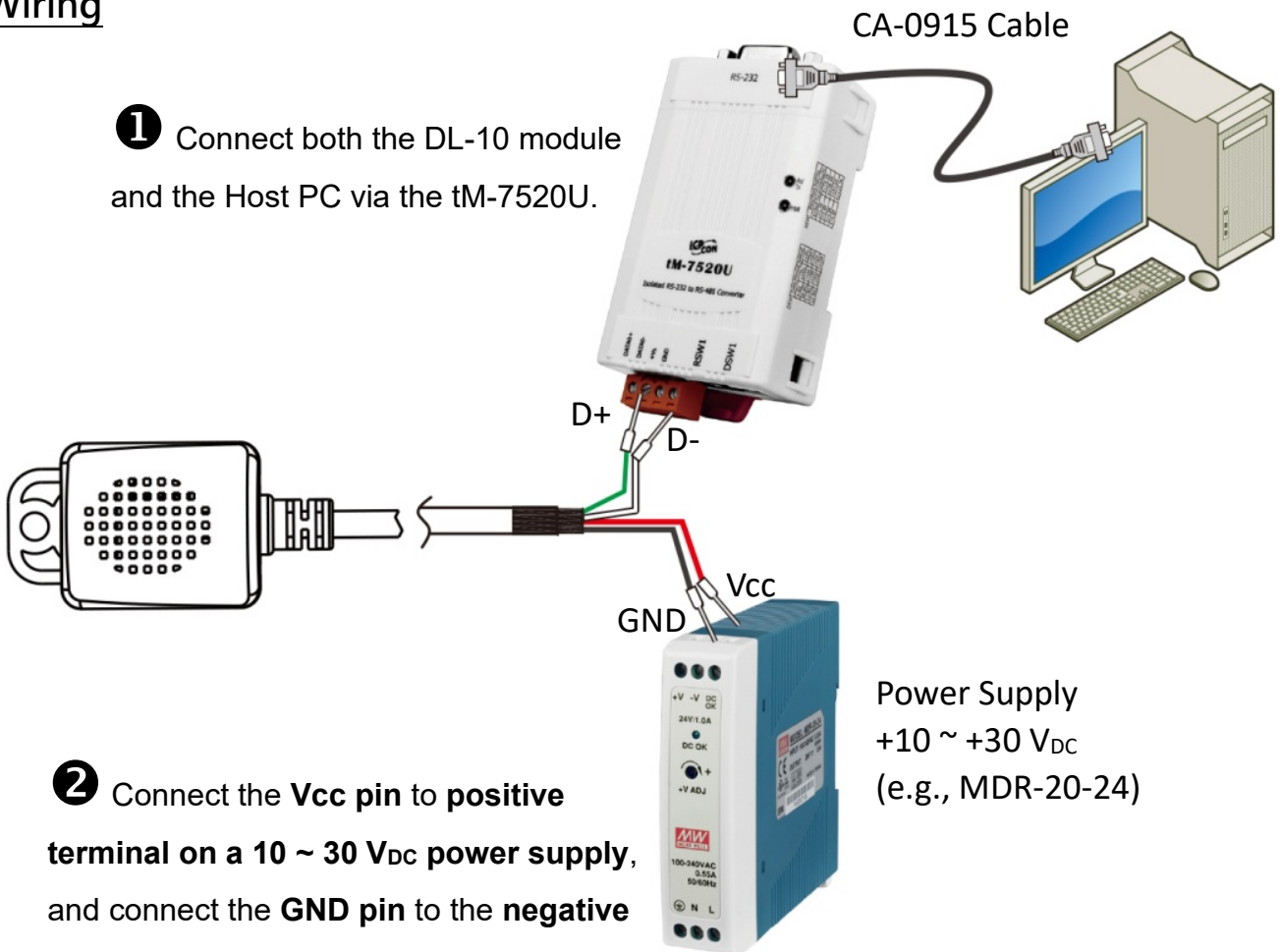

2 Connect the **Vcc** pin to **positive** terminal on a **10 ~ 30 V_{DC}** power supply, and connect the **GND** pin to the **negative** terminal.

3.2 Installing Software on Your PC



Decompress **DCON Utility Pro.zip**, which can be obtained from the ICP DAS web site at

 http://ftp.icpdas.com/pub/cd/8000cd/napdos/driver/dcon_utility/

3.3 Search Module

Step 1

Run the DCON Utility Pro software



DCON_Utility_Pro.exe
DCON_Utility_Pro_PC

Double click the DCON_Utility_Pro.exe.



Step 2



Click the  button to open the "Comport Option" dialog box.

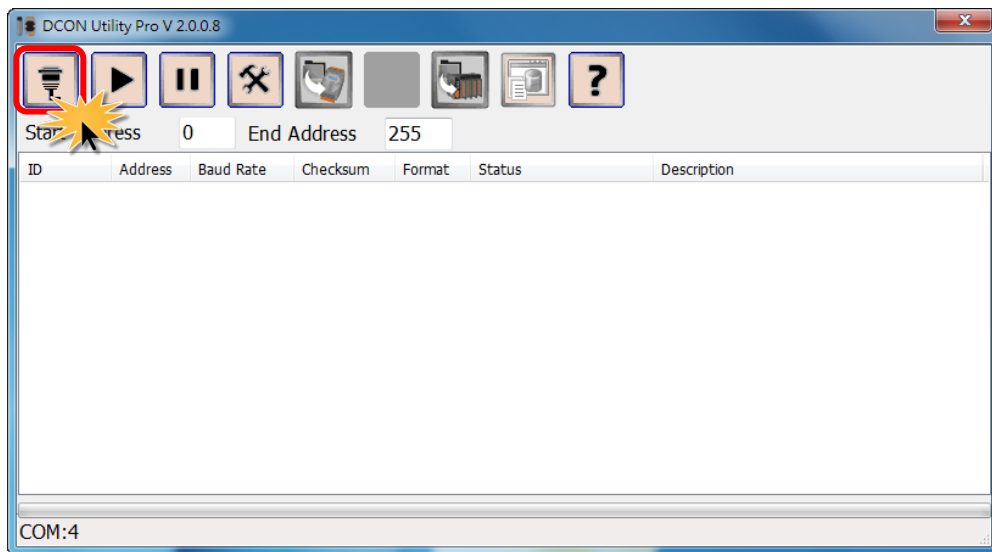

Step 3

Select COM Port (e.g., COM9) depends on Host PC COM port that connects to DL-10.

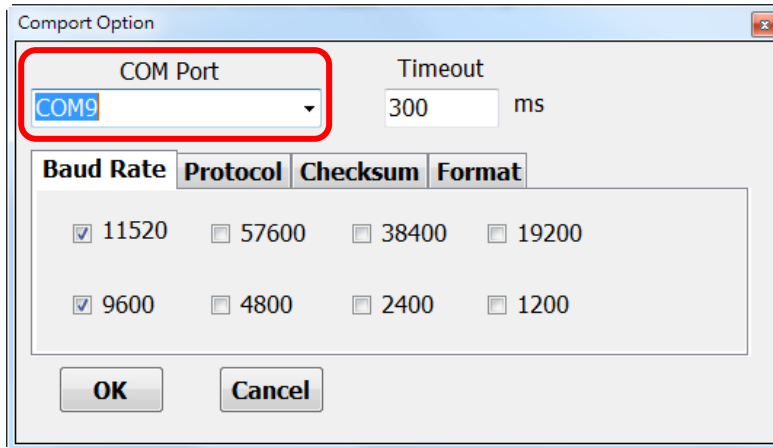

Step 4

Select the Baud Rate (e.g., 9600 and 115200) depends on DL-10 in the Baud Rate option.

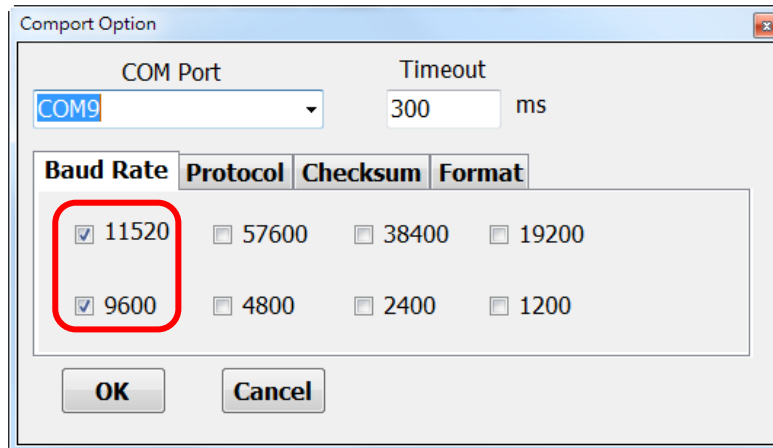

Step 5

Select the protocol (e.g., Modbus RTU) depends on DL-10 in the Protocol option.

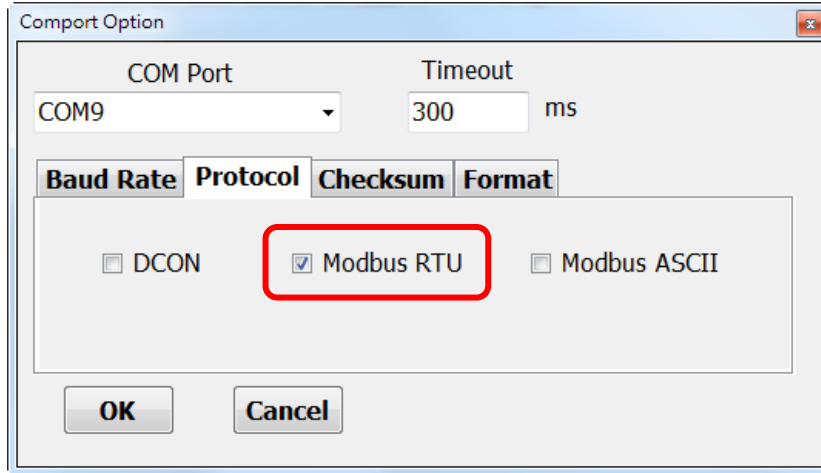

Step 6

Select the Data Format (e.g., N, 8, 1) depends on DL-10 in the Format option and click "OK" button.

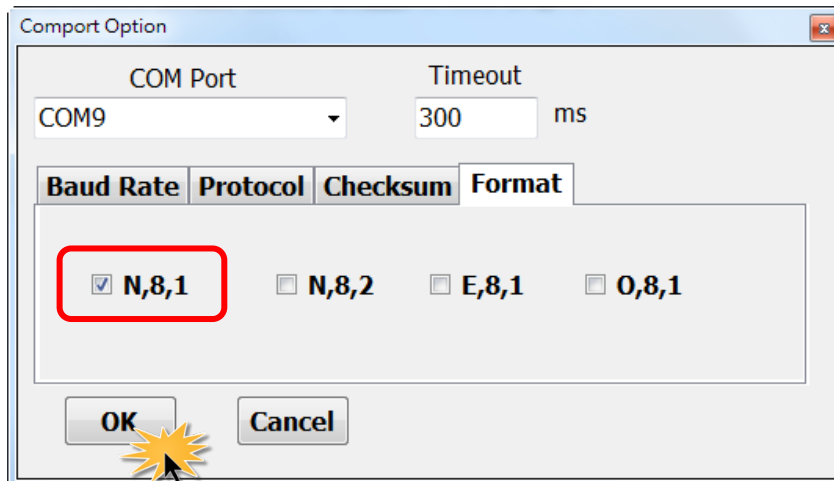

Step 7

Click the  button to search DL-10 module.

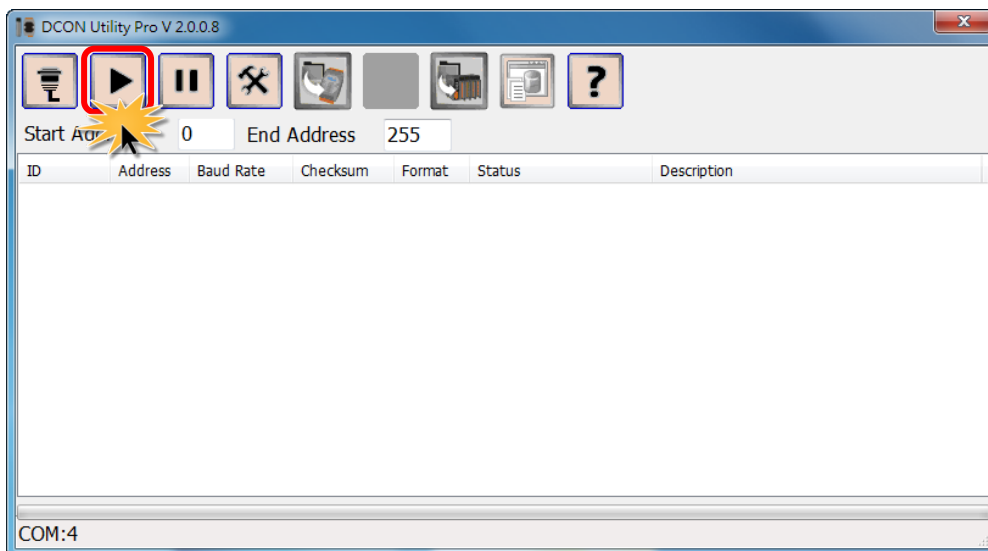

Step 8

The DL-10 module will be displayed in list and click the  button.

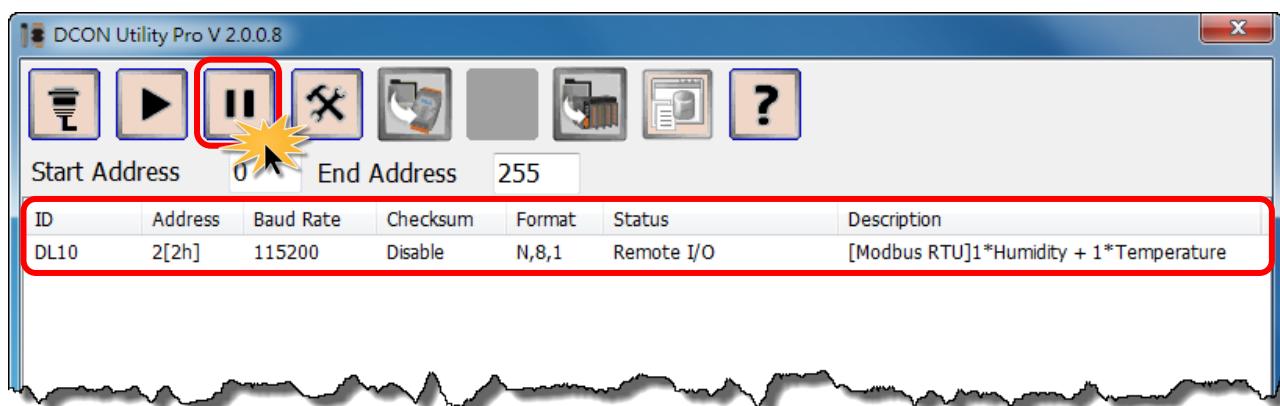

How to solve when the DCON Utility cannot find the DL-10 module?

Ensure that the power supply and the RS-485 wiring for the DL-10 are configured correctly, refer to the [Section 3.1 Connecting the Power and the Host PC](#). If the DCON Utility still cannot find the DL-10 when normal wiring and power up, please follow the procedure described below:

1. Use the blade of a flat-head screwdriver to set the “**Init Switch 1**” on the DL-10 to the “**ON**” (**Init Mode**) position, and **reboot** the DL-10 module.

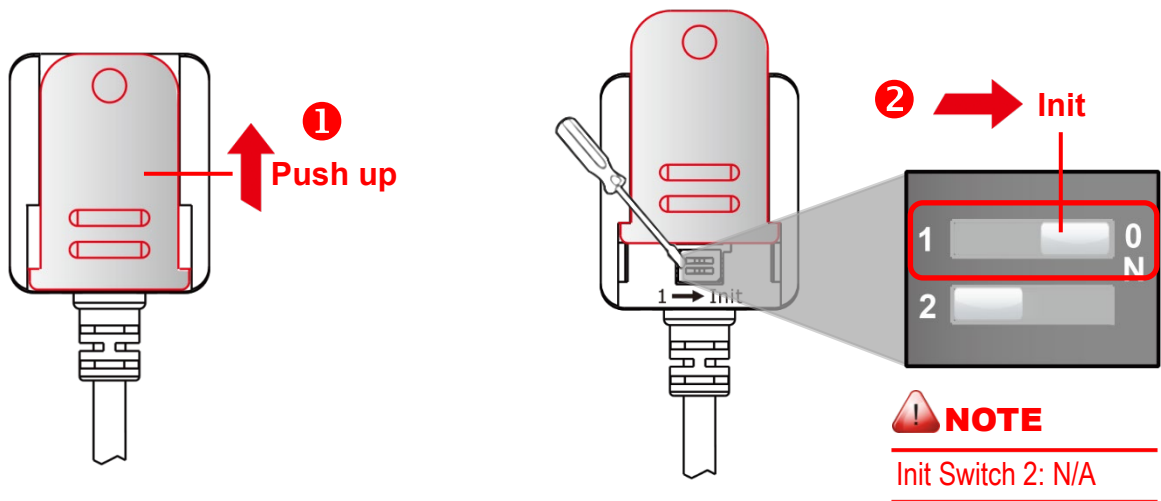

2. In the **Init mode**, refer to **Steps 2 to 8** in “[Section 3.3 Search Module](#)” to execute the search again.
3. Confirm that the DCON Utility has found the DL-10, use the blade of a flat-head screwdriver to set the “**Init Switch 1**” on the DL-10 to the “**1**” (**Run Mode**) position, and **reboot** the DL-10 module.

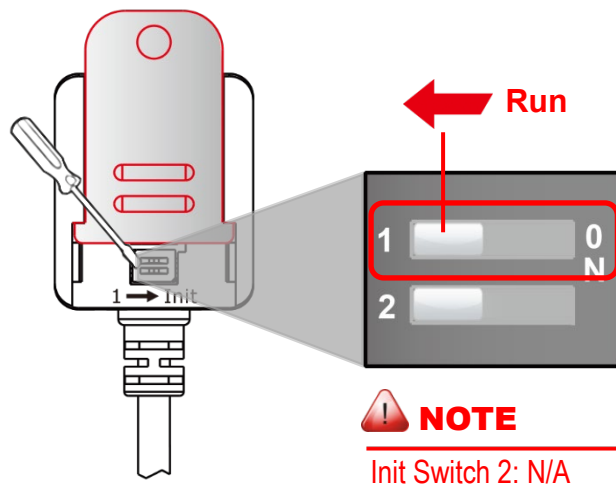

3.4 Configuring Module

In the DCON Utility Pro software, click the module name to open the “DL10 Firmware[0100]” dialog box, allowing you to configure the settings for DL-10 and verify the humidity and temperature, each of which will be described in more detail below.

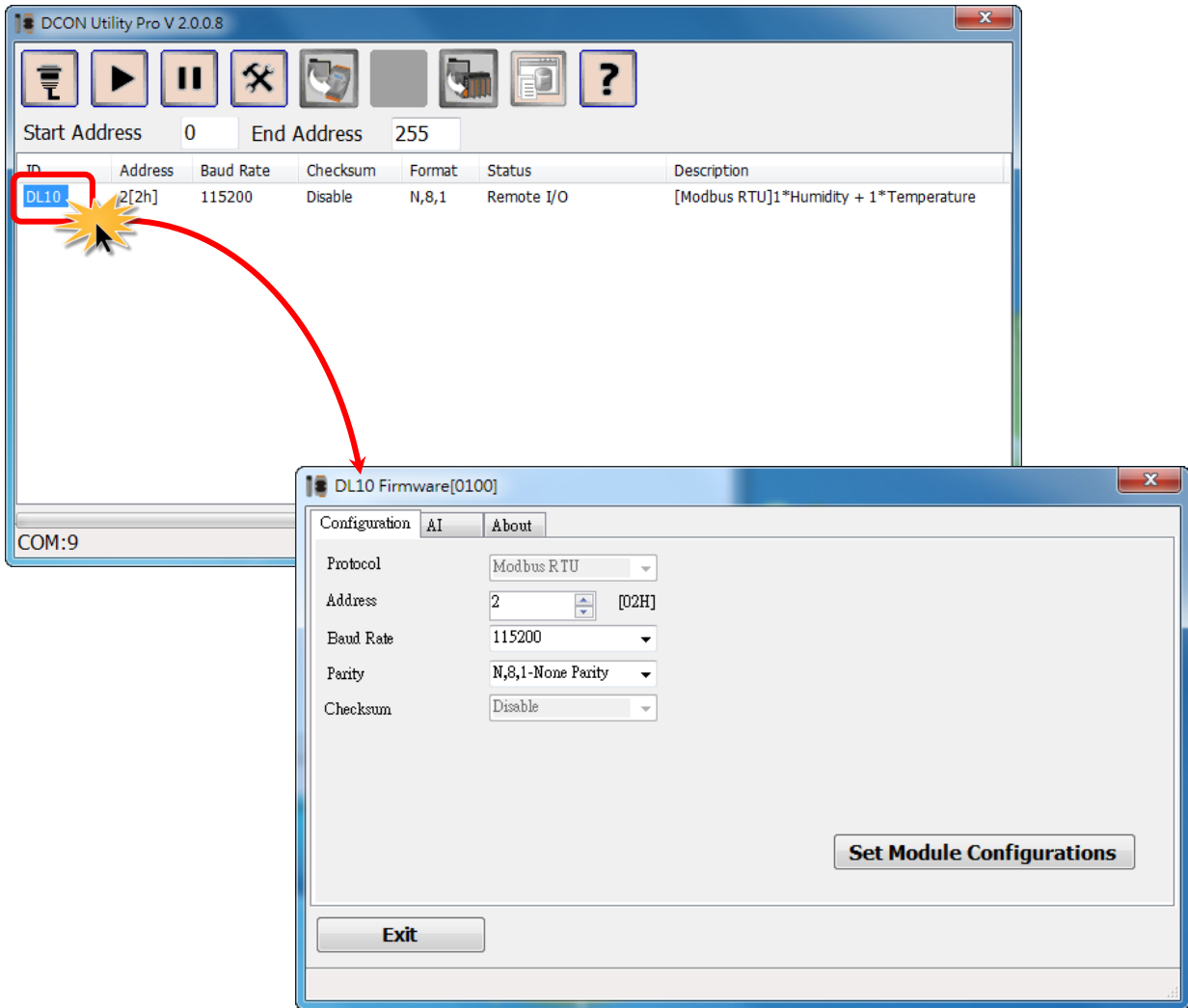

Configuration

After click the “Configuration” tab will display the configuration page allowing you to configure the settings for DL-10, including the Address, Baud Rate and Data Format.

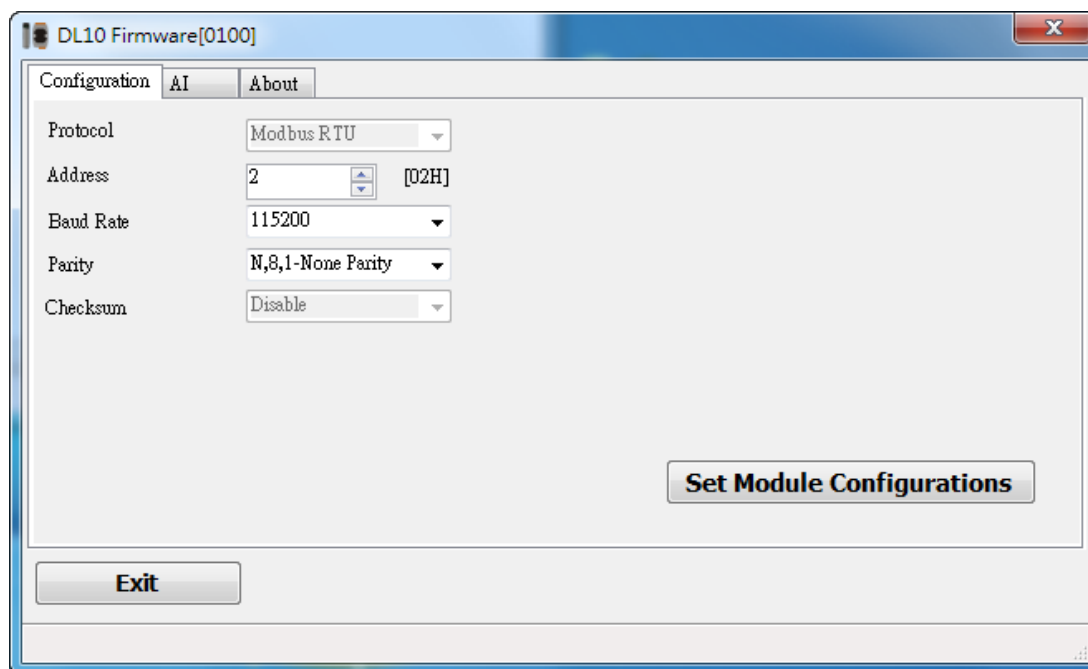

The following is an overview of the parameters:

Item	Description
Address	Set the device ID for the DL-10.
Baud Rate	Set the Baud Rate for the RS-485 Port.
Parity	Set the Data Format for the RS-485 Port.
Set Module Configurations	Click this button to save the revised settings to the DL-10.

AI (Humidity & Temperature)

Click the “AI” tab to see the measured humidity and temperature values.

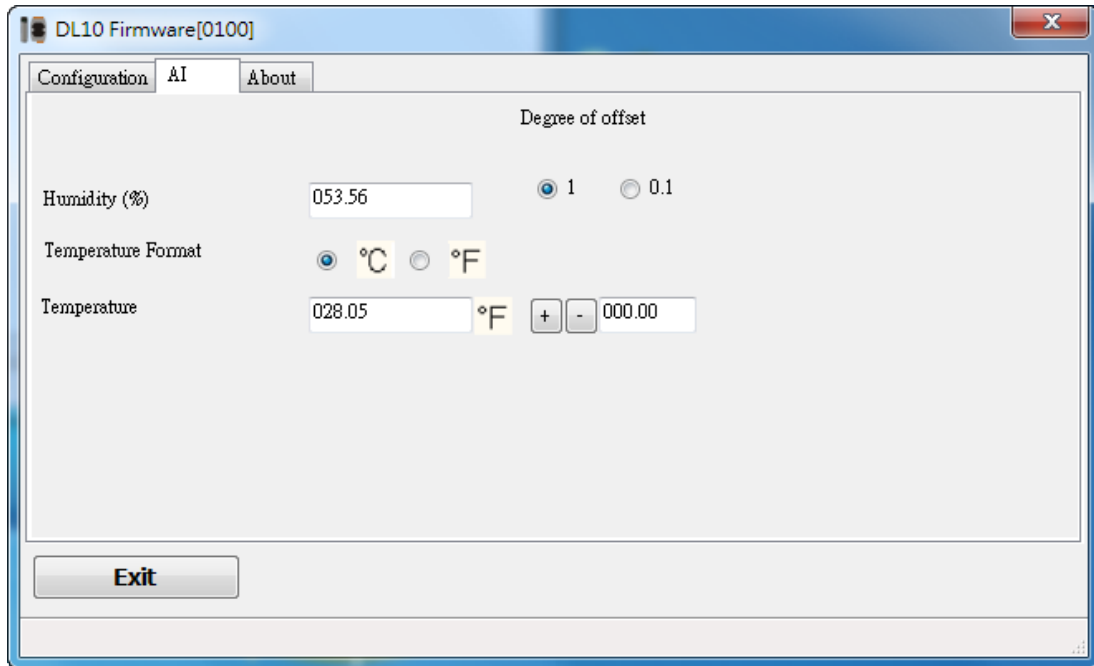

The following is an overview of the parameters:

Item	Description
Humidity(%)	Display humidity value
Temperature Format	Set the temperature to Degrees Celsius(°C) or Fahrenheit(°F)
Temperature	Display temperature value
Degree of offset	Set the temperature offset value. If the offset is 1 degree, pressing“+” or “-” button once will increase or decrease set temperature by 1 degree. If the offset is 0.1 degree, pressing“+” or “-” button once will increase or decrease set temperature by 0.1 degree.

4. Modbus Register Table

Discrete Inputs (1xxxx)

Register		Points	Description	Data Format	Attribute
DEC	HEX				
10272	0110	1	Read the reset status of a module. 0: The module has not been reset since the last read. 1: The module has been reset, and this is the first time to read the value.	0: Not Reset 1: Resetted	R

Input Register (3xxxx)

Register		Points	Description	Data Format	Attribute
DEC	HEX				
30001	000	1	Read the humidity value (unit: 0.0.1 %)	0 ~ 10000	R
30002	001	1	Read the temperature value in degrees Celsius (unit: 0.01°C)	-32768 ~ 32767	R
30003	002	1	Read the temperature value in degrees Fahrenheit (unit: 0.01°F)	-32768 ~ 32767	R
30004	003	1	Read the dew point temperature value in degrees Celsius (unit: 0.01°C)	-32768 ~ 32767	R
30005	004	1	Read the dew ppint temperature value in degrees Fahrenheit (unit: 0.01°F)	-32768 ~ 32767	R
30481	1E0	1	Read the firmware version (Minor number) Hexadecimal Representation	-	R
30482	1E1	1	Read the firmware version (Major number) Hexadecimal Representation	-	R
30483	1E2	1	Read the module name High byte = 0x00 Low bye = 0x10	0x0010	R

30484	1E3	1	Read the module name High byte = 0x52(ASCII: D) Low byte = 0x48(ASCII: L)	0x444c	R
-------	-----	---	---	--------	---

Holding Register (4xxxx)

Register		Points	Description	Data Format	Attribute	Factory Value
DEC	HEX					
40449	1C0	1	Read/Write the temperature offset value (unit: 0.01°C)	-32768 ~ 32767	R/W	0
40450	1C1	1	Read/Write the humidity offset value (unit: 0.01%)	-32768 ~ 32767	R/W	0
40485	1E4	1	Read/Write the Device ID	1 ~ 247	R/W	01
40486	1E5	1	Read/Write the Baud Rate (bps) and Data Format Bit-5:Bit-0 (Baud Rate) 03: 1200 04: 2400 05: 4800 06: 9600 07: 19200 08: 38400 09: 57600 0A: 115200 Bit-7:Bit-6 (Data Format) 00: no parity, 1 Stop bit 01: no parity, 2 Stop bits 10: even parity, 1 Stop bit 11: odd parity, 1 stop bit	0x03 ~ 0xCA	R/W	0x0A

Appendix: Revision History

This chapter provides revision history information to this document.

The table below shows the revision history.

Revision	Date	Description
1.4	May. 2024	Add the descriptions of dew point temperature value and humidity offset value to Modbus Register Table on Page 16.
1.3	Aug. 2019	Amended the Device ID of the factory default settings to 1 on Page 6.
1.2	Aug. 2018	Amended the Measureing range on page 5.
1.0	Jul. 2017	Initial issue