

# PM-3133/ PM-3133P/ PM-3133-RCT

## Smart Power Meter

### User's Manual



ICP DAS Co., Ltd.

No. 111, Guangfu N. Rd., Hukou Township, Hsinchu County,  
Taiwan 30351, R.O.C.

TEL : 886-3-597-3366 FAX : 886-3-597-3733

[http:// www.icpdas.com](http://www.icpdas.com) E-mail : [service@icpdas.com](mailto:service@icpdas.com)

# Revision History

The table below shows the revision history:

Revision	Date	Description
1.13	2024/04/25	<ul style="list-style-type: none"> <li>● Fix the Integer type value range of kVAh,kVARh</li> </ul>
1.14	2025/2/4	<ul style="list-style-type: none"> <li>● Added Chapter 8: Introduction to EtherNet/IP Communication</li> <li>● Enhanced and expanded content in existing sections</li> </ul>
1.15	2025/8/20	<ul style="list-style-type: none"> <li>● Section 1.1: Revised the Introduction and Features</li> <li>● Section 2.1: Added specifications and information for models PM-3133-RCTxxxP and PM-3133P</li> <li>● Section 3.3.2 to 3.3.5: Revised content related to CT positional accuracy and installation steps</li> <li>● Section 4.2: Updated the content and diagram regarding connection and wiring.</li> <li>● Section 6.2.2 (for Modbus versions): Added Modbus Coil Registers [System Boolean Setting Value], modified Modbus Holding Registers [System Parameter Setting] and Modbus Input Registers [ Power value (Float) ]</li> <li>● Section 9.3.3 (for CANopen, -CPS version): Added Guarding and Heartbeat parameters to Store and Restore Object</li> <li>● Section 9.3.4 (for CANopen, -CPS version): Added the Firmware Update Object to CANopen functionality</li> <li>● Appendix: Updated content and added Q15, Q16</li> </ul>
1.16	2025/11/21	<ul style="list-style-type: none"> <li>● Section 2.1: Added Models PM-3133-CPS / PM-3133P-CPS / PM-3133-RCT-CPS</li> <li>● Section 3.3.2 to 3.3.5: Revised content related to CT positional accuracy and installation steps</li> <li>● Section 4.2: Updated the content and diagram regarding connection and wiring.</li> <li>● Appendix: Updated content and added Q17, Q18</li> </ul>

1.17	2025/12/31	● Appendix Q8: Add CT cable length note. Added Q19.
------	------------	---

# Table of Contents

<b>1.</b>	<b>INTRODUCTION</b> .....	<b>7</b>
1.1.	PM-3133/PM-3133P/PM-3133-RCT Introduction .....	7
1.2.	Safety Guidelines .....	9
1.3.	Disclaimer.....	9
1.4.	Product Warranty and Customer Support.....	10
1.4.1.	Warranty Limitations .....	10
<b>2.</b>	<b>SPECIFICATIONS</b> .....	<b>11</b>
2.1.	Specifications .....	11
2.2.	Naming Rules.....	13
<b>3.</b>	<b>INSTALLATION</b> .....	<b>14</b>
3.1.	Inspection.....	14
3.2.	Safety .....	14
3.3.	Dimension and Latch.....	15
3.3.1.	Mounting and Dismounting .....	16
3.3.2.	PM-3133-xxx_xxxP CT's Installation Steps.....	18
3.3.3.	PM-3133-RCTxxxP CT Connection .....	19
3.3.4.	PM-3133-RCTxxxP CT's Installation Steps .....	20
3.3.5.	PM-3133-RCTxxxP CT's installation steps Precautions.....	21
3.3.6.	PM-3133P Current Input Scaling.....	24
<b>4.</b>	<b>WIRING DIAGRAMS</b> .....	<b>25</b>
4.1.	Connection .....	25
4.2.	Wiring.....	28

<b>5.</b>	<b>RELAY OUTPUT &amp; LED INDICATOR.....</b>	<b>32</b>
5.1.	Relay .....	32
5.2.	LED Indicator.....	32
<b>6.</b>	<b>MODBUS-RTU COMMUNICATION.....</b>	<b>33</b>
6.1.	RS-485 Settings .....	33
6.2.	Modbus-RTU Setting.....	36
6.2.1.	Specifications .....	36
6.2.2.	Modbus Register .....	38
<b>7.</b>	<b>MODBUS-TCP COMMUNICATION .....</b>	<b>48</b>
7.1.	Default Settings .....	48
7.1.1.	Ethernet Configurations .....	49
7.2.	Connecting the Power Meter and Host PC.....	51
7.2.1.	Without PoE (Power over Ethernet) .....	51
7.2.2.	With PoE (Power over Ethernet) .....	51
<b>8.</b>	<b>ETHERNET/IP COMMUNICATION .....</b>	<b>52</b>
8.1.	Default Settings .....	52
8.1.1.	Utility configurations .....	52
8.2.	EtherNet/IP Protocol.....	53
8.2.1.	Object Model .....	53
8.2.2.	Explicit Message .....	55
8.2.3.	Implicit Message .....	56
8.2.4.	Power Meter Data Frame.....	57
8.3.	Connecting the Power and Host PC.....	63
8.3.1.	Without PoE(Power over Ethernet) .....	63
8.3.2.	With PoE(Power over Ethernet ): .....	63

<b>9.</b>	<b>CANOPEN COMMUNICATION.....</b>	<b>64</b>
9.1.	CANopen Settings.....	64
9.2.	CANopen Protocol.....	67
9.2.1.	SDO Introduction.....	67
9.2.2.	PDO Introduction.....	78
9.2.3.	NMT Introduction.....	85
9.2.4.	Special Functions for PM-3133-CPS.....	91
9.3.	Object Dictionary of PM-3133-CPS.....	93
9.3.1.	Communication Profile Area.....	93
9.3.2.	Manufacturer Specific Profile Area.....	99
9.3.3.	Store and Restore Object.....	102
9.3.4.	Firmware Update Object.....	103
<b>10.</b>	<b>APPENDIX: QUESTIONS &amp; ANSWERS.....</b>	<b>104</b>

# 1. Introduction

## 1.1. PM-3133/PM-3133P/PM-3133-RCT Introduction

**ICP DAS presents the PM-3133, PM-3133P and PM-3133-RCT series** — advanced, compact, and cost-effective smart power meters designed for real-time three-phase power monitoring across a wide range of applications.

With high accuracy (PM-3133: <0.5%, PM-3133-RCT: <2%, PF=1), these meters support power monitoring on both low voltage (primary side) and medium/high-voltage (secondary side) systems. They deliver reliable and precise energy consumption data for equipment in operation, helping users improve energy management and enhance operational efficiency.

The PM-3133, PM-3133P and PM-3133-RCT series support a wide input voltage range of 10 to 500 VAC, ensuring compatibility with global power systems.

The **PM-3133-RCT** features **Rogowski Coil technology** — a flexible, rope-style current transformer (CT) that simplifies installation in confined spaces. It supports large window size ranging from 55 mm to 185 mm, making it ideal for applications where conventional CTs cannot be easily installed.

The **PM-3133P** does not include current transformers (CTs) by default, allowing users to choose their own 333mV output CTs according to specific application requirements. However, it does not support Rogowski coils.

## Features :

- True RMS Power Measurements
- Energy Analysis for 3P4W-3CT, 3P3W-2CT, 3P3W-3CT, 1P2W-1CT, 1P3W-2CT
- Voltage Measurements Up to 500 V
- Clip-on CT for Easy Installation (PM-3133 and PM-3133-RCT)
- Current Measurement Capabilities
  - PM-3133P Series: Supports 333 mV output CTs; actual current range depends on the CT's primary rating
  - PM-3133-xxxP Series: Current measurements up to 400 A.
  - PM-3133-RCTxxxP Series: Current measurements up to 4000 A
- Power Measurement Accuracy
  - PM-3133P Series: Accuracy is approximately 2–5% (PF = 1), depending on the CT used. The CT ratio must be set correctly.
  - PM-3133-xxxP Series: Accuracy better than  $\pm 0.5\%$  (Power Factor = 1)
  - PM-3133-RCTxxxP Series:
    - For -500P and -1000P models: Accuracy better than  $\pm 2\%$  (PF = 1, Input Current > 50 A)
    - For -2000P and -4000P models: Accuracy better than  $\pm 2\%$  (PF = 1, Input Current > 200 A)
- Bi-directional Energy
- Supports 2-Power Relay Output (Form A)
- Total Harmonic Distortion (THD)

## 1.2. Safety Guidelines

The PM-3133 contains hazardous voltages and requires careful handling during installation and operation. Adhere to the following safety guidelines to prevent injury or damage:

- The meter contains hazardous voltages and must never be disassembled. Failure to follow this practice may result in serious injury or death.
- Any work on or near energized meters, meter sockets, or other metering equipment poses a risk of electrical shock.
- Only qualified industrial electricians or metering specialists should perform installation and maintenance.
- ICP DAS assumes no responsibility for improper installation or failure to comply with national and local electrical codes.

## 1.3. Disclaimer

ICP DAS assumes no liability for any damage resulting from the use of this product. The company reserves the right to revise or modify this document at any time without prior notice.

- The information provided in this manual is believed to be accurate and reliable. However, ICP DAS assumes no responsibility for its use or for any infringements of patents or third-party rights resulting from its use.
- ICP DAS is not liable for any technical or editorial errors, omissions, or inaccuracies contained in this document.

## 1.4. Product Warranty and Customer Support

ICP DAS warrants that all products, under normal use conditions, will be free from defects in materials and workmanship for a period of one (1) year from the date of shipping. During the warranty period, ICP DAS will, at its discretion, repair or replace any defective product. This warranty applies only under normal use conditions and does not cover damages caused by misuse, improper installation, or failure to comply with relevant regulations.

### To report a defect:

1. Contact ICP DAS:
  - Phone: **+886-3-597-3366**
  - Email: [service@icpdas.com](mailto:service@icpdas.com)
2. Provide the following information:
  - Product model number and serial number
  - A detailed description of the issue
  - If the issue pertains to specific readings, include all relevant meter readings for reference.

### Returning merchandise:

- A product serial number (SN) is required before sending any product back to ICP DAS.

### 1.4.1. Warranty Limitations

The warranty does not apply to defects resulting from:

- Unauthorized modifications.
- Misuse or operation outside the specified conditions.
- Use for purposes other than electrical power monitoring.

### Important Note:

The PM-3133 is not a user-serviceable product. Any attempt to disassemble or repair the device will void the warranty.

## 2. Specifications

### 2.1. Specifications

Model	PM-3133/ PM-3133P/ PM-3133-RCT	PM-3133-MTCP/ PM-3133P-MTCP/ PM-3133-RCT-MTCP	PM-3133-EIP/ PM-3133P-EIP/ PM-3133-RCT-EIP	PM-3133-CPS/ PM-3133P- CPS / PM-3133-RCT- CPS
<b>AC Power Measurement</b>				
Wiring	1P2W-1CT, 1P3W-2CT, 3P3W-2CT, 3P3W-3CT and 3P4W-3CT			
Measurement Voltage	10 to 500 V (CAT III)			
Measurement Current	PM-3133-005P: CTØ10 mm (0.05 A – 5 A) PM-3133-100P: CTØ10 mm (0.05 A – 60 A) PM-3133-160P: CTØ16 mm (0.1 A – 100 A) PM-3133-240P: CTØ24 mm (0.15 A – 200 A) PM-3133-360P: CTØ36 mm (0.3 A – 300 A) PM-3133-400P: CTØ36 mm (0.3 A – 400 A) PM-3133-RCT500P: CTØ55 mm (5 A – 500 A) PM-3133-RCT1000P: CTØ80 mm (5 A – 1000 A) PM-3133-RCT2000P: CTØ105 mm (5 A – 2000 A) PM-3133-RCT4000P: CTØ185 mm (5 A – 4000 A) PM-3133P: Supports 333 mV output CTs; actual current range depends on CT's primary rating			
Measurement Frequency	50-60 Hz			
W Accuracy	<b>PM-3133 Series:</b> For -005P models: Accuracy better than $\pm 0.5\%$ (PF = 1, Input Current > 0.5 A) For -100/-100P models: Accuracy better than $\pm 0.5\%$ (PF = 1, Input Current > 1.5 A) For -160/-160P models: Accuracy better than $\pm 0.5\%$ (PF = 1, Input Current > 3 A) For -240P models: Accuracy better than $\pm 0.5\%$ (PF = 1, Input Current > 3.5 A) For -360P models: Accuracy better than $\pm 0.5\%$ (PF = 1, Input Current > 7 A) For -400P models: Accuracy better than $\pm 0.5\%$ (PF = 1, Input Current > 10 A)  <b>PM-3133-RCT Series:</b> For -500P/-1000P models: Accuracy better than $\pm 2\%$ (PF = 1, Input Current > 50 A) For -2000P/ -4000P models: Accuracy better than $\pm 2\%$ (PF = 1, Input Current > 200 A)			

	<b>PM-3133P Series:</b> Accuracy is approximately 2–5% (PF = 1), depending on the CT used. The CT ratio must be set correctly			
Power Parameter Measurement	True RMS voltage (Vrms), True RMS current (Irms), Active Power (kW), Active Energy (kWh), Apparent Power (kVA), Apparent Energy (kVAh), Reactive Power (kVAR), Reactive Energy (kVARh), Power Factor (PF), Frequency(Hz)			
Data Update Rate	1 Second			
<b>Communication</b>				
RS-485	Protocol	Modbus-RTU	-	
	Baud rate	9600,19200 (default), 38400, 115200; DIP Switch Selectable		
	Data format	N,8,1 (default); N,8,2; E,8,1; E,8,2; O,8,1; O,8,2 ( FW version 1.07)	-	
	Isolation	3000 VDC	-	
	Bias Resistor	No(Typically provided by the RS-485 Master; alternatively, a tM-SG4 or SG-785 can be used to provide bias)		
Ethernet	Protocol	-	Modbus TCP	EtherNet/IP
	PoE	-	Yes, IEEE 802.3af	
CANopen	Protocol	-		CANopen
	Baud rate	-	125 k (default), 250 k, 500 k, 1 M; DIP Switch Selectable	
	Isolation	-	3000 VDC	

Alarm Output			
Power Relay	Form A (Normal Open) x 2; Relay Contact Voltage Range: 5 A @ 250 VAC (47 to 63Hz), 5 A @ 30 VDC		
Aux Power			
Input Range	+12 to 48 VDC	+12 to 48 VDC or PoE	+12 to 48 VDC
Power Consumption	2 W		
Dimensions (W x L x H)	127 mm x 105 mm x 33 mm		
Environment			
Operating Temperature	-20 to +70 °C		
Storage Temperature	-40 to +80 °C		

## 2.2. Naming Rules



## 3. Installation

### 3.1. Inspection

The instrument may not function properly under the following conditions:

- a) The exterior is visibly damaged.
- b) It does not display properly after powering on.
- c) It has been stored for an extended period under harsh conditions.
- d) It has been damaged during transportation.

### 3.2. Safety

- Please clean the instrument using a soft, dry cloth.
- Do not use chemicals, detergents, or volatile solvents to clean the instrument, as they may cause damage to the cover.
- The product includes external split type clip-on CTs. Do not disconnect or replace them with other CTs, as this is strictly prohibited.
- Carefully read this operation manual before use.
- Re-confirm the measurement position before installation.
- The PM-3133 series can be installed using rail mounting or embedded mounting, without the need for drilling holes or using screws. The rail width should not exceed 35 mm.
- The meter's auxiliary power supply range is DC +12V to +48V.

### 3.3. Dimension and Latch

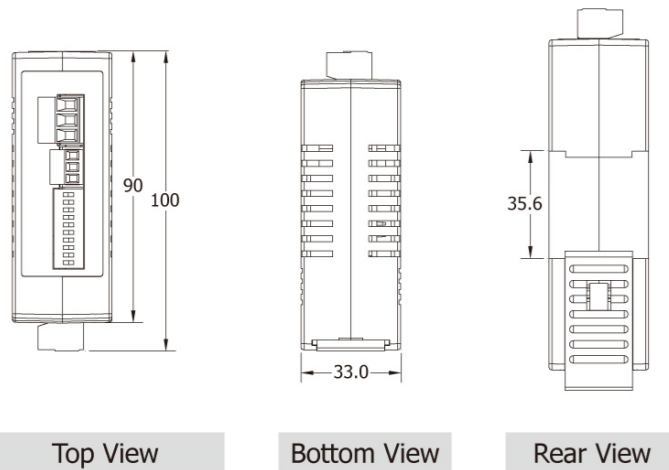
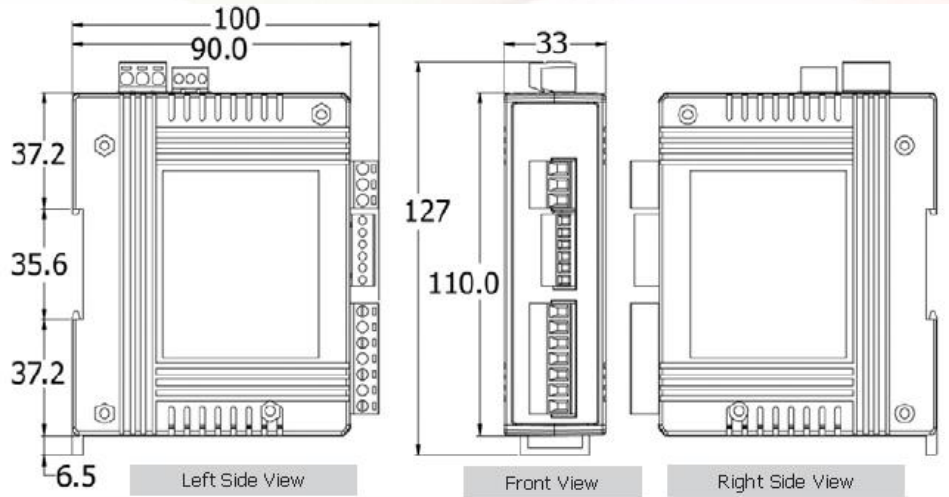

### 3.3.1. Mounting and Dismounting

- A. Mounting:** Place the PM-3133 onto the rail. Then press the front of the PM-3133 toward the mounting surface until you hear it click into place.

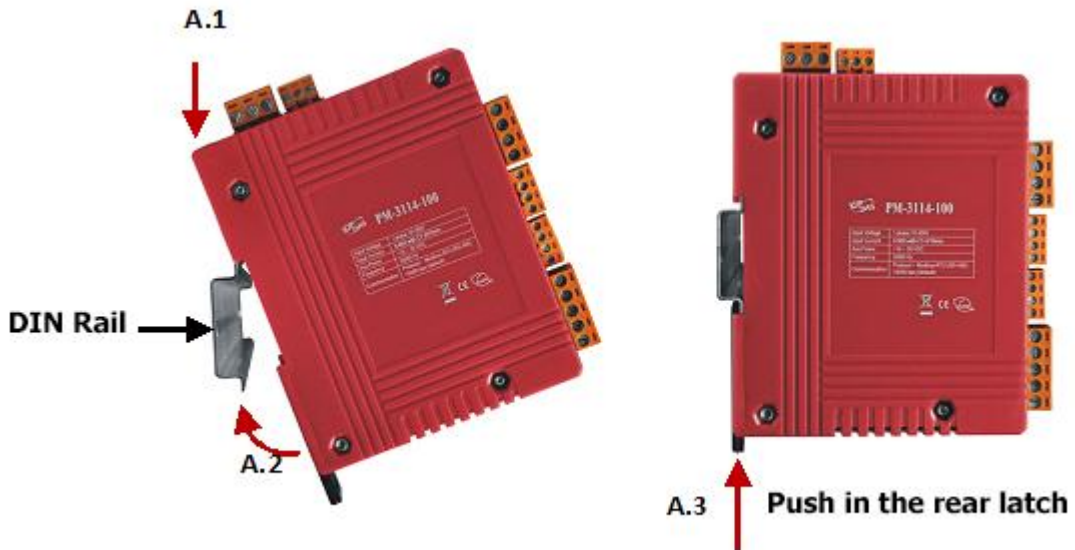

- B. Dismounting:** Pull out the rear latch and remove the PM-3133 from the rail.

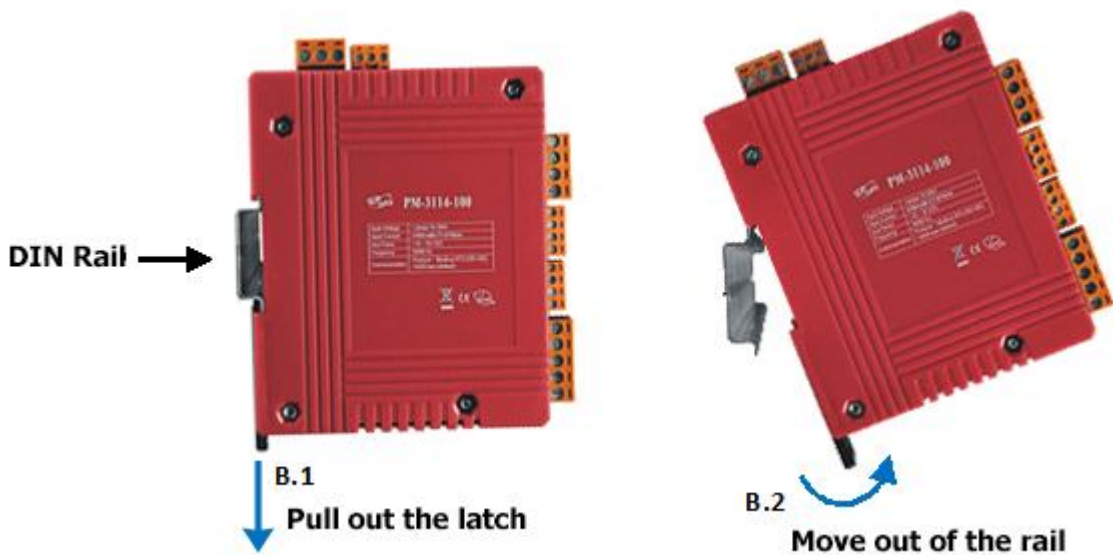

**C. Wire Disconnection:**

1. Unlock the CT clip and remove the CT from the power cable, avoiding disconnecting the CT terminal wires if possible (do not disconnect the terminal wires first).

**Warning!** If you need to remove the CT terminal wires, make sure to first detach the CT before removing the CT terminal wires. This is to prevent high open-circuit secondary voltage being generated on the secondary side of the CT, which could cause electric shock or damage to the CT and connected equipment in the secondary circuit.

2. Disconnect the voltage input wires from the terminals and wrap the wire ends with insulating tape.
3. Disconnect the communication wires from the terminal.
4. Disconnect the auxiliary power from the terminal, then wrap the wire ends with insulating tape.



CT Input Terminal Wires

### 3.3.2. PM-3133-xxx\_xxxP CT's Installation Steps

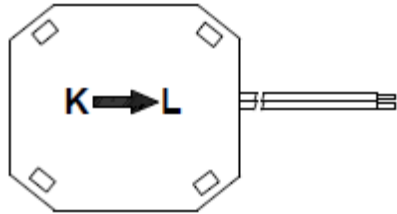

Bottom view



- At the bottom of the CT, there is a “K→L” mark.

- Open the CT clip.



- Make sure the power current direction follow the “K→L” marking on the CT and then close the CT clip.

- Complete the Installation.

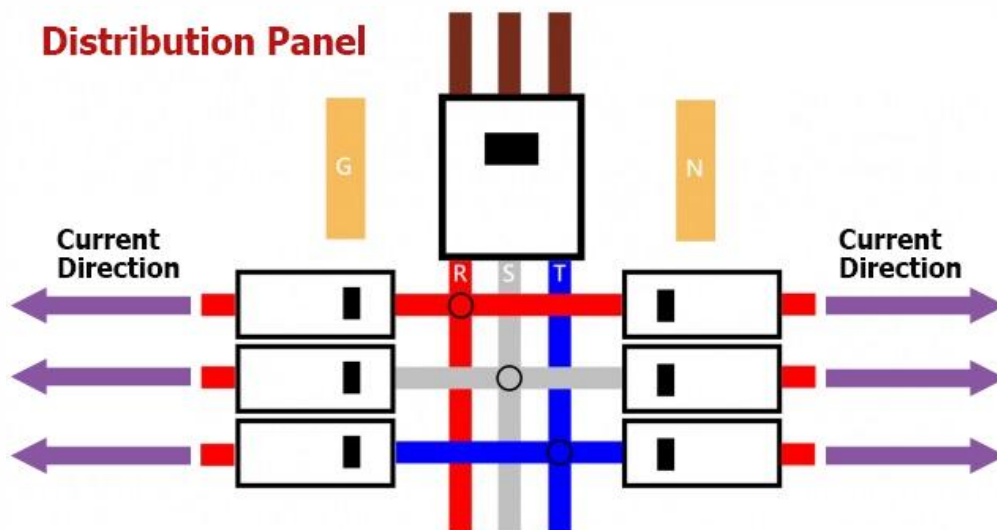

### 3.3.3. PM-3133-RCTxxxP CT Connection

Please firstly check the current input terminal, and then and then in white (or red) - black, white (or red) - black, white (or red) - black wire sequences (CT1-P1, CT1-P2, CT2-P1, CT2-P2, CT3-P1, CT3-P2). Then connect the CT's, and close the CT clip. Make sure the arrow direction sign on CT's follows current flow direction.

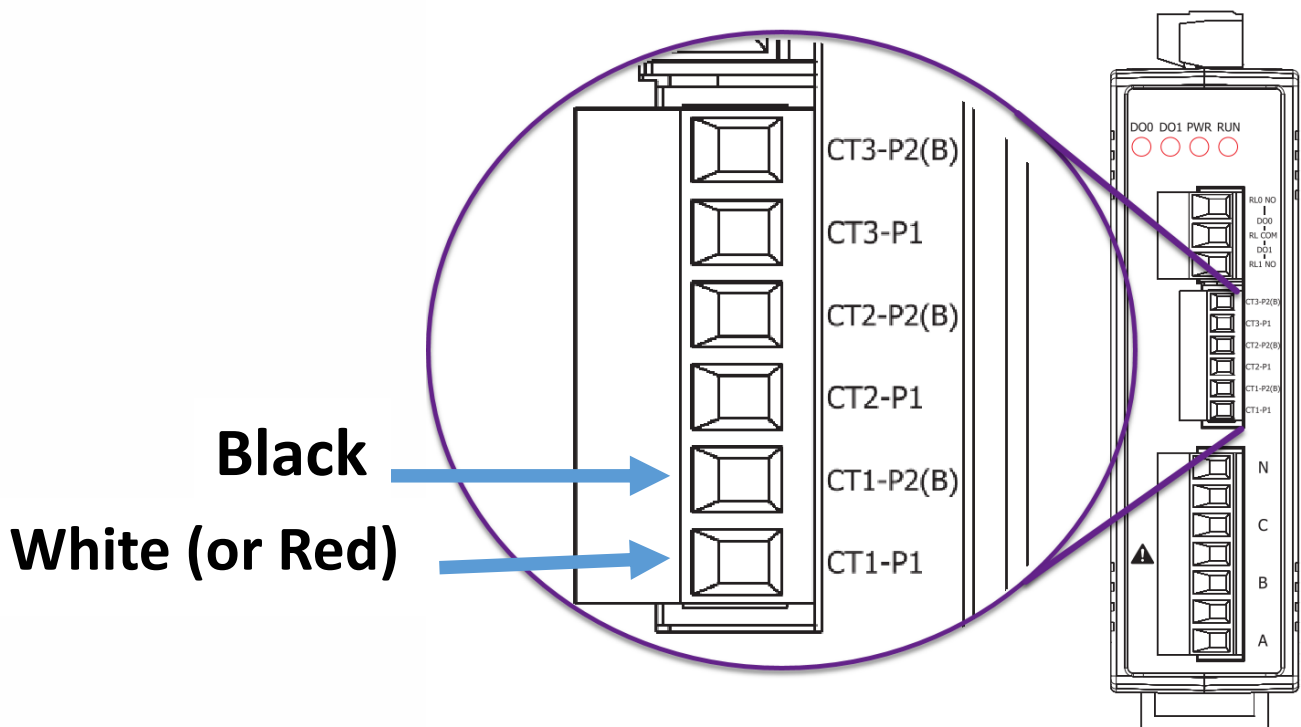

### 3.3.4. PM-3133-RCTxxxP CT's Installation Steps

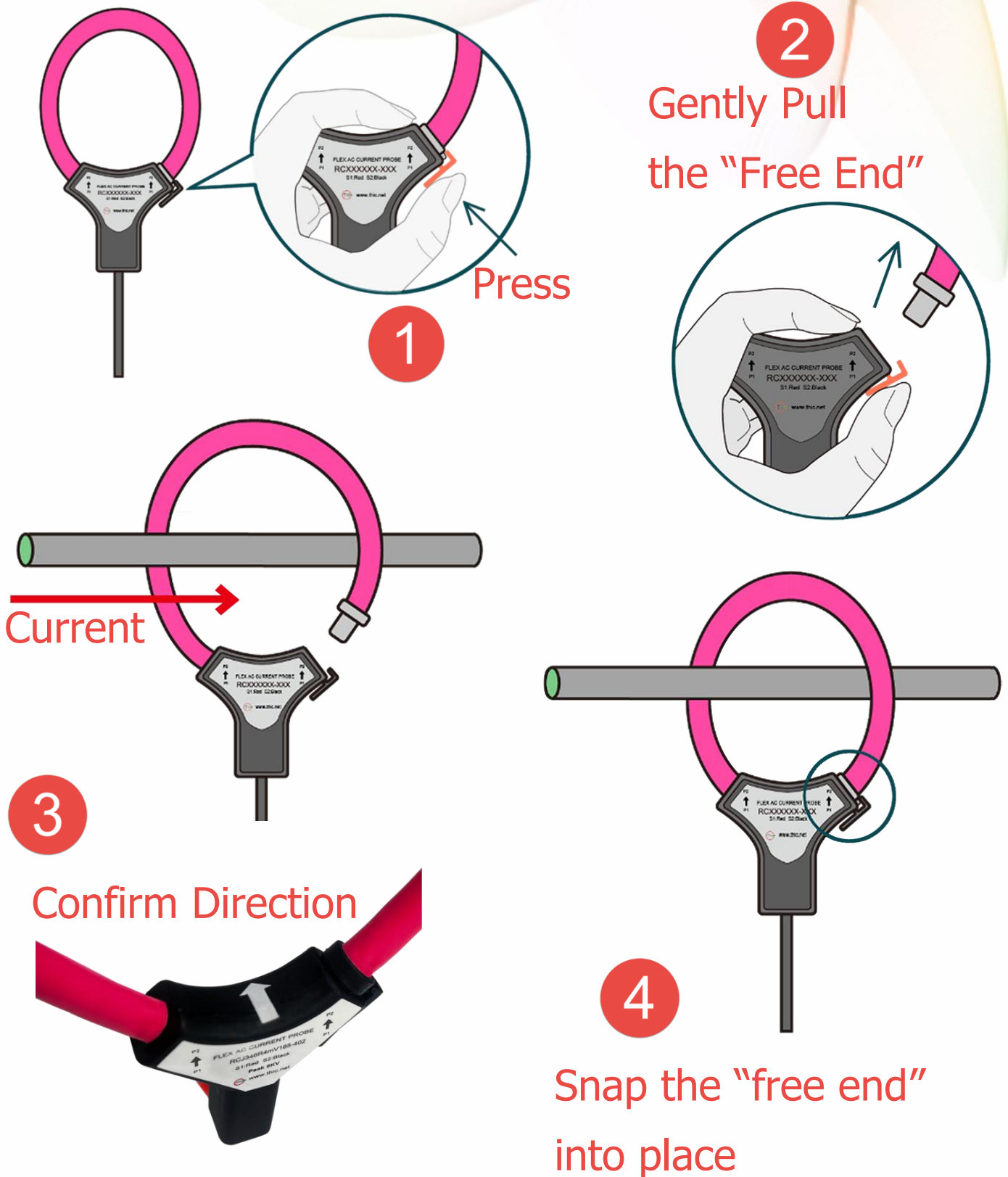

### 3.3.5. PM-3133-RCTxxxP CT's installation steps

#### Precautions

1. The ICP DAS Rogowski power meter is calibrated with the conductor positioned at the center (Position A in Figure 1.0), which is the ideal location to ensure measurement accuracy.
2. The Rogowski coil is not a completely closed circular structure, as it has a connection joint. The dashed area at Position D in Figure 1.0 indicates the location of this connection. It is known that when the measured conductor is placed closer to this area, the measurement error increases because magnetic flux variations in that section cannot be properly detected. Please avoid measuring current within the dashed area, as doing so may result in measurement errors exceeding  $-5\%$ . Moreover, external magnetic flux can also affect the connection section, further increasing measurement errors.

Before performing current measurements, ensure that all other current-carrying conductors, except the one being measured, are kept away from the Rogowski coil's connection section as much as possible.

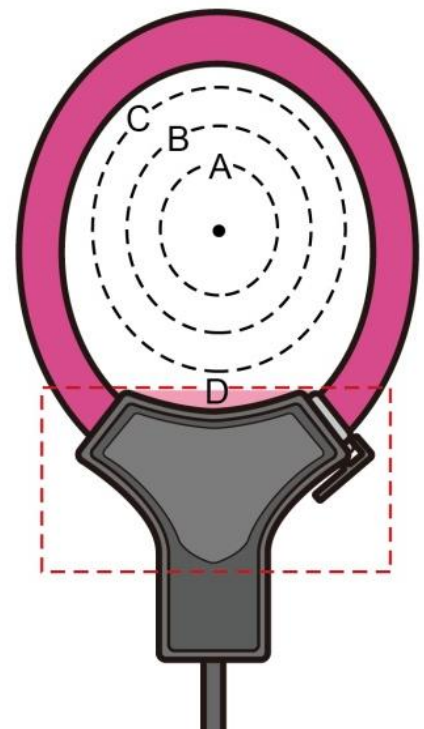

Figure 1.0

3. In practical applications, if the measured conductor is offset from the center of the Rogowski coil, tilted, or if the conductor size is disproportionate to the coil diameter, the measurement accuracy may be affected. When the conductor is only slightly tilted or off-center, the meter can still maintain acceptable measurement accuracy, but the error will increase accordingly. To achieve higher measurement precision, it is recommended to keep the measured conductor as perpendicular to the coil as possible and ensure it passes through the center of the coil. Figure 1.1 illustrates the recommended cable tie fixation method to minimize tilt.

In Figure 1.2, when the conductor's tilt angle is large and its position is close to the coil's connection end, the measurement error becomes the greatest.

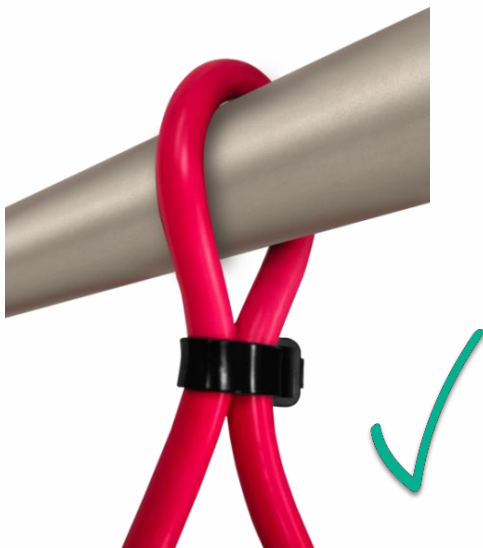

Figure 1.1

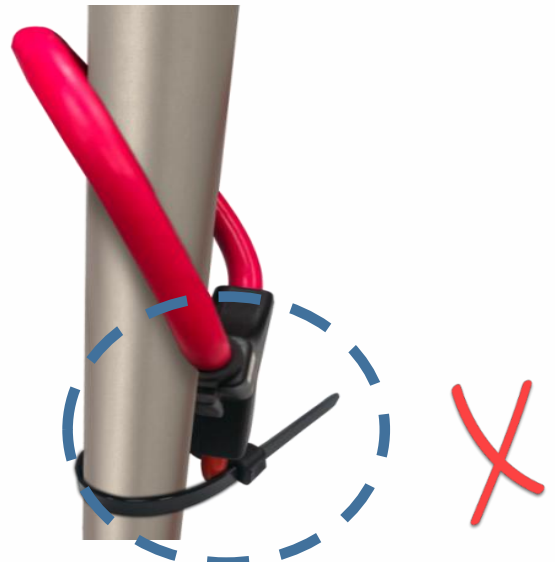

Figure 1.2

### Good Installation Method

1. The cable tie is fastened close to the wire to prevent the CT from slipping.
2. The tilt angle is small.
3. Avoid positioning the CT near location D.

### Poor Installation Method

1. Large tilt angle.
2. Too close to connection point D

4. At lower input currents (approximately 5%–15% of the rated current), the Rogowski coil exhibits relatively higher measurement error.

The recommended operating current range vs. measurement accuracy is shown in the table below:

Rated Current	Recommended Operating Current Range	Low Current Range Error (5%–15% of Rated Value)	Mid-to-High Current Range Accuracy (15%–100% of Rated Value)
500A	50A – 500A	Higher Error (±2%–±4%)	Within ±2%; if the conductor is positioned at the center (Position A in Figure 1.0), the accuracy can be further improved to within ±1%.
1000A	50A – 1000A		
2000A	200A – 2000A		
4000A	200A – 4000A		

5. Do not extend the Rogowski coil's lead wires by yourself.

Modifying the lead length will disrupt the original shielding structure, allowing external electromagnetic interference to couple into the sensing signal, which may cause waveform distortion and reduced measurement accuracy.

If a special or extended lead length is required, please contact ICP DAS to obtain a factory-designed version with proper shielding treatment.

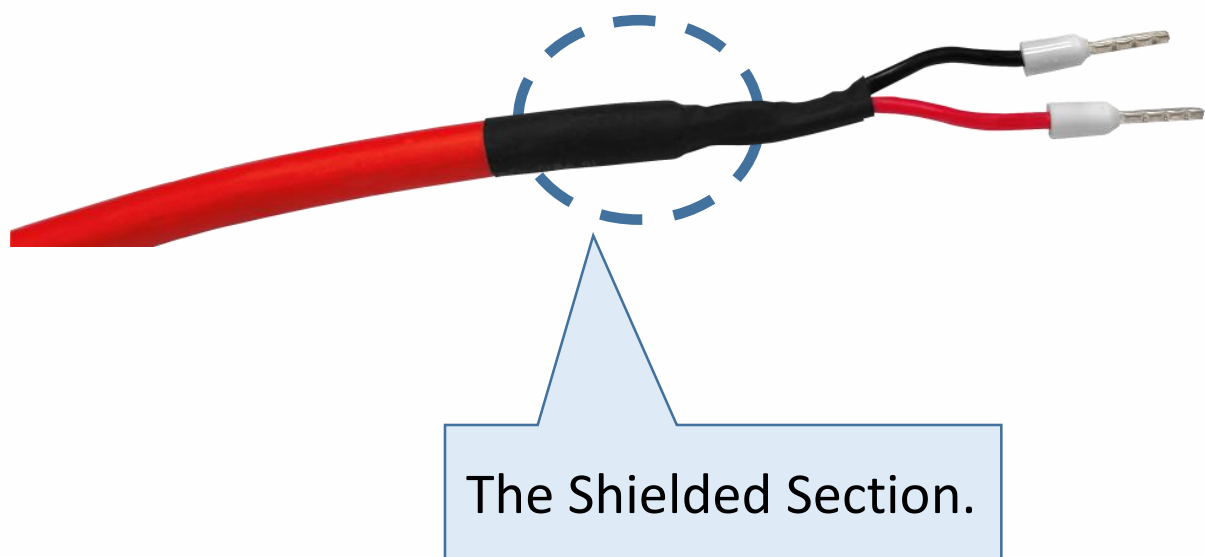

### 3.3.6. PM-3133P Current Input Scaling

1. The external CT's are fragile, please handle with care.
2. **The current input of PM-3133P series is in mV range.** The other CT's, for example, from panel will damage the instrument due to its large current (around 5A)
3. **CT Selection Considerations:**

Adding current transformer (333mV Output CTs) has the effect of reducing the measured current by the CT ratio (let's say 40:1 for 200A CT as example). So a current of 200A becomes 5A. Since the meter sees 5A, many of the measurements it reports will be low by a factor of 40 unless they are scaled up by 40.

Current transformer	CT Ratio	Current transformer	CT Ratio
50A CT	10:1	400A CT	80:1
60A CT	12:1	800A CT	160:1
100A CT	20:1	1000A CT	200:1
200A CT	40:1	1200A CT	240:1

**Note:**

- A. Please use **low phase angle error** CTs: essential for accurate power and energy measurements. (Example: phase error  $<2^\circ$ )
- B. Accuracy is approximately 2–5% (PF = 1), depending on the CT used. The CT ratio must be set correctly
- C. **PM-3133P only for external 333mV Output CTs (Rogowski coils are not supported).**  
Safe: burden resistor built-in, 333 mVac voltage output at rated full scale current, no shorting blocks needed.
- D. This meter requires external CT(s) to operate:  
1P2W-1CT requires 1 CT per meter.  
3P3W-2CT/1P3W-2CT requires 2 CTs per meter.  
3P4W-3CT/3P3W-3CT requires 3 CTs per meter

# 4. Wiring Diagrams

## 4.1. Connection

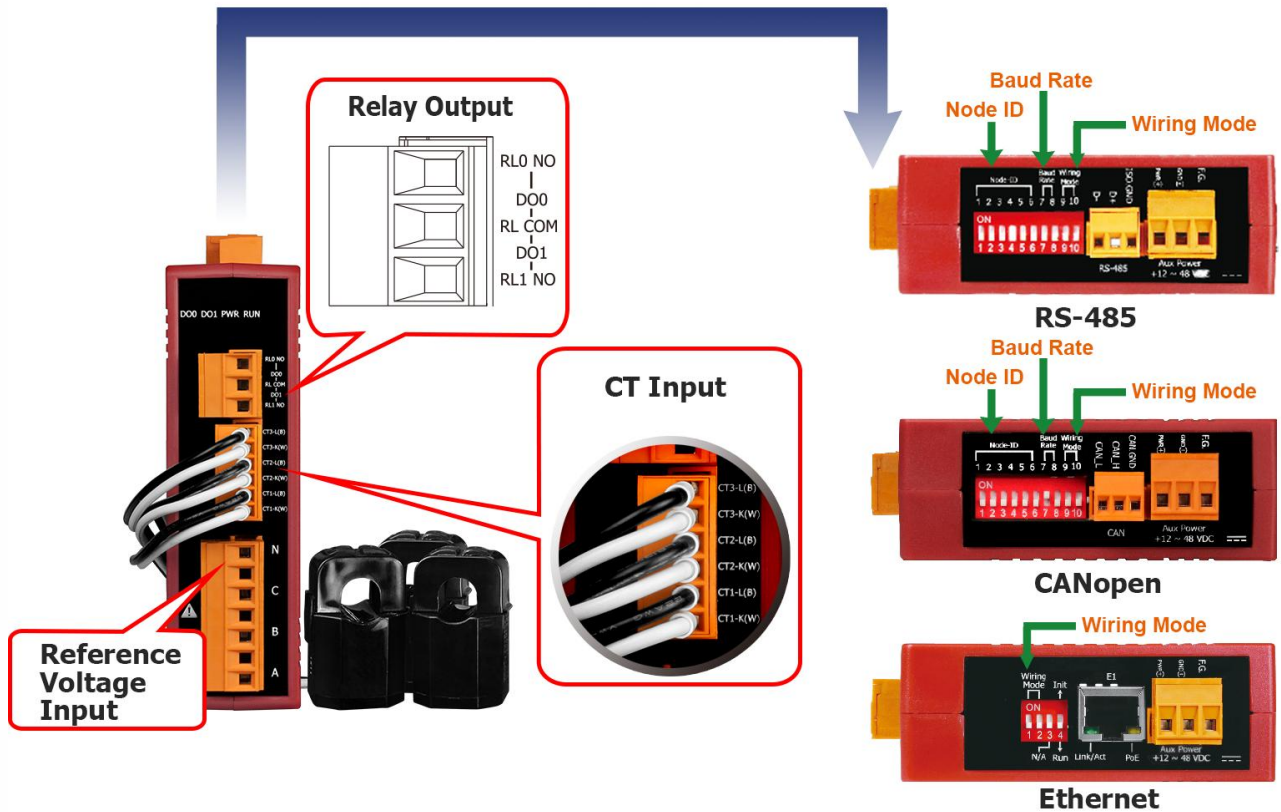

### Wiring Specifications:

- **CT (Current Transformer) Wires:** AWG 16 to 28, Screw Torque Value: 1.7 lb-in
- **Reference Voltage Wires:** AWG 12 to 24, Screw Torque Value: 7.0 lb-in
- **Auxiliary Power:** AWG 12 to 24, Screw Torque Value: 7.0 lb-in
- **Relay Output:** AWG 12 to 24, Screw Torque Value: 7.0 lb-in

### Voltage Input

1. PM-3133 series supports input voltage up to 500VAC.  
For input voltage exceeding 500VAC, use a PT (power transformer), and adjust the PT RATIO settings.
2. Confirm the RST (ABC) phase sequence.

### Current Input

1. Handle external CTs with care, as they are fragile.
2. Only use the CTs provided with the device. Using other CTs (e.g., from a panel), could damage the instrument due to their high current (around 5A)
3. When multiple smart meters (PM-3133 series) are installed, do not interchange CTs between devices. Each set of meters and their split-type clip-on CTs are calibrated individually. Mixing them may result in inaccurate measurements.
4. To ensure correct installation, verify the CT wiring sequences before clipping the CTs onto the power cable of the monitoring equipment.
5.  **When measuring current, never open the secondary circuit of a CT while the primary has a load. Always detach the CT before removing the terminal wires to prevent injury.**
6. Exercise extra caution when working in confined space with CTs.
7. The current flow direction must follow K-L marking on the CT.
8. Select the appropriate CT size based on the diameter of the monitored equipment's power cable:
  - For power cable diameter  $< \Phi 10$ , suitable for a 60A CT.
  - For power cable diameter  $\Phi 10$  to  $\Phi 16$ , suitable for a 100A CT.
  - For power cable diameter  $\Phi 16$  to  $\Phi 24$ , suitable for a 200A CT.
  - For power cable diameter  $\Phi 36$ , suitable for either a 300A CT or a 400A CT.
9. Do not exceed the rated current value of the CT.

### CT Dimensions(Units: mm)

005:CTΦ10mm (5 A Max.)  
 100:CTΦ10mm (60 A Max.)



360:CTΦ36mm (300 A Max.)

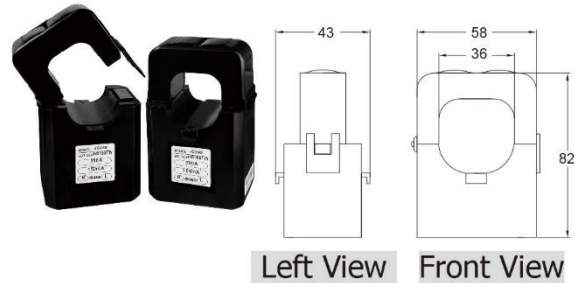

160:CTΦ16mm (100 A Max.)



400:CTΦ36mm (400 A Max.)

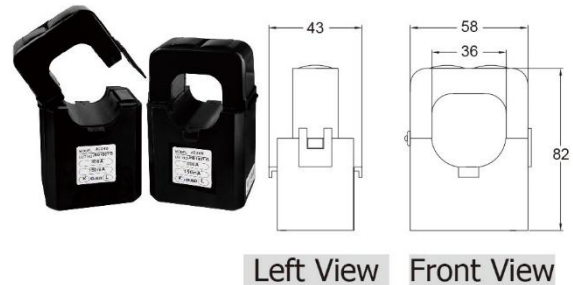

240:CTΦ24mm (200 A Max.)

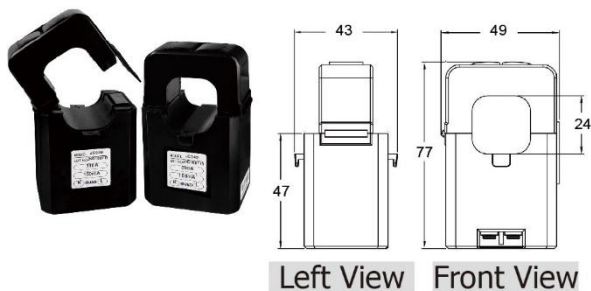

Models	A (Inside diameter)	B (Outer diameter)
PM-3133-RCT500P	55mm	68mm
PM-3133-RCT1000P	80mm	93mm
PM-3133-RCT2000P	105mm	118mm
PM-3133-RCT4000P	185mm	199mm

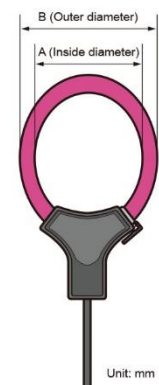

Unit: mm

**Note:** The length of the CT wires can be extended up to 8 meters (except for Rogowski coil CTs) without compromising accuracy.

It is recommended to use **AWG 16 to 28 twisted pair wires** with a **screw torque value of 1.7 lb-in** to reduce interference.

## 4.2. Wiring

- SW9 - SW10 Settings

For the PM-3133,

- All five wiring modes — **1P2W-1CT**, **1P3W-2CT**, **3P3W-2CT**, **3P3W-3CT**, and **3P4W-3CT** — can be configured via the [Wiring Mode] register, after setting **DIP switches 9 and 10** to **Software Setting** mode.
- Alternatively, for **3P3W-2CT**, **3P3W-3CT**, and **3P4W-3CT**, you may choose to configure them using **DIP switches** as shown below:

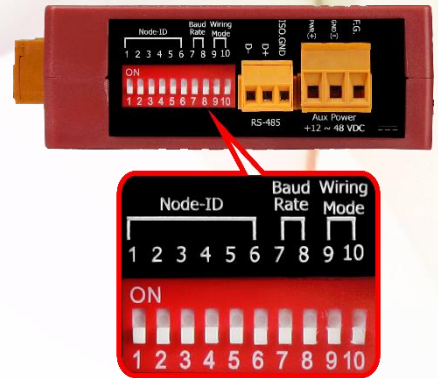

Wiring	SW 9	SW 10
Software Setting	OFF	OFF
3P3W-2CT	ON	OFF
3P3W-3CT	OFF	ON
3P4W-3CT	ON	ON

- 1P2W-1CT(Single-phase, Single-circuit) (Configuration required via software)

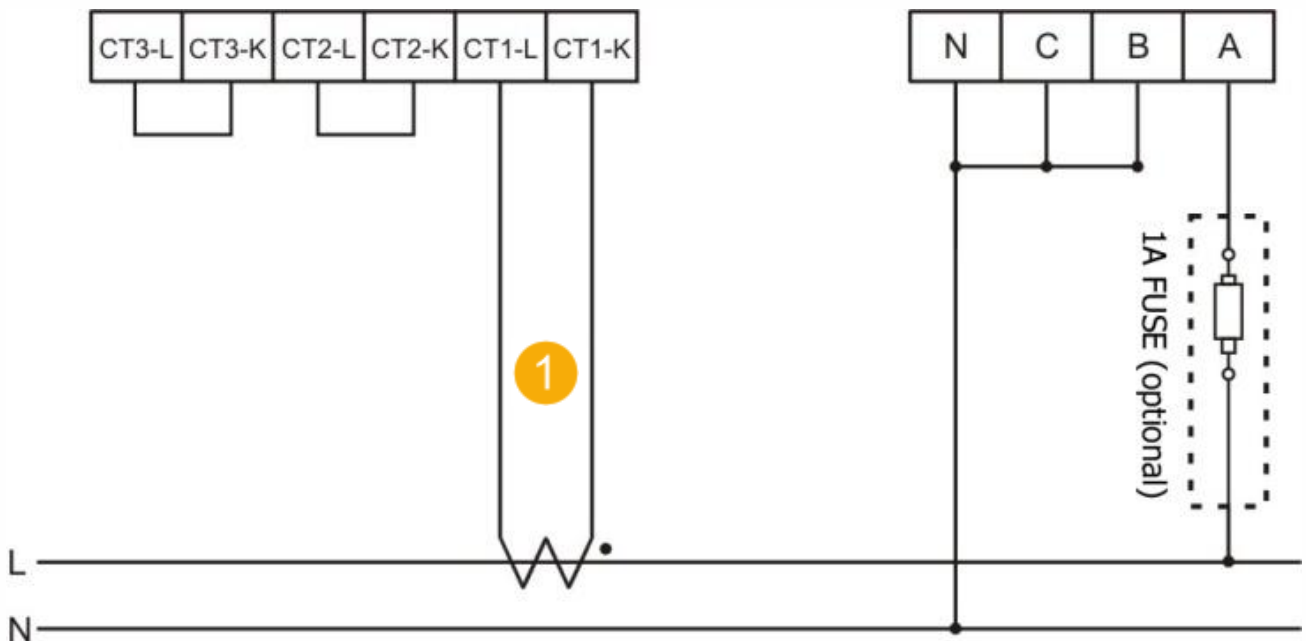

- 1P2W-3CT  
(Single-phase, 3-circuit) (Configuration required via software. Select "1P2W-1CT" as the wiring configuration.)

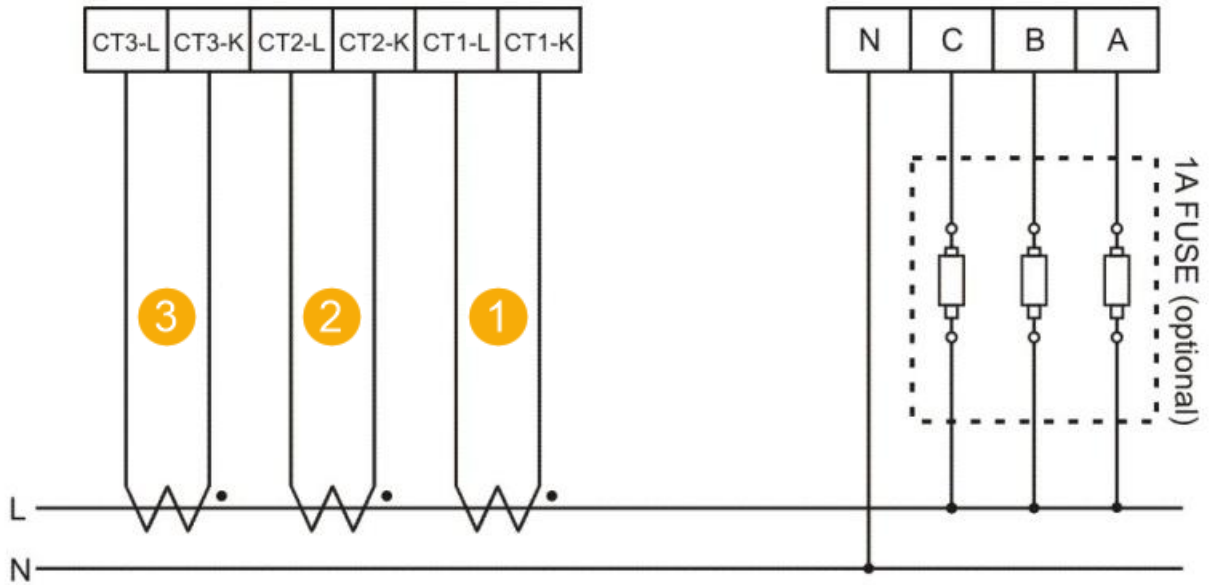

- 1P3W-2CT  
(Single-phase, Single-circuit) (Configuration required via software)

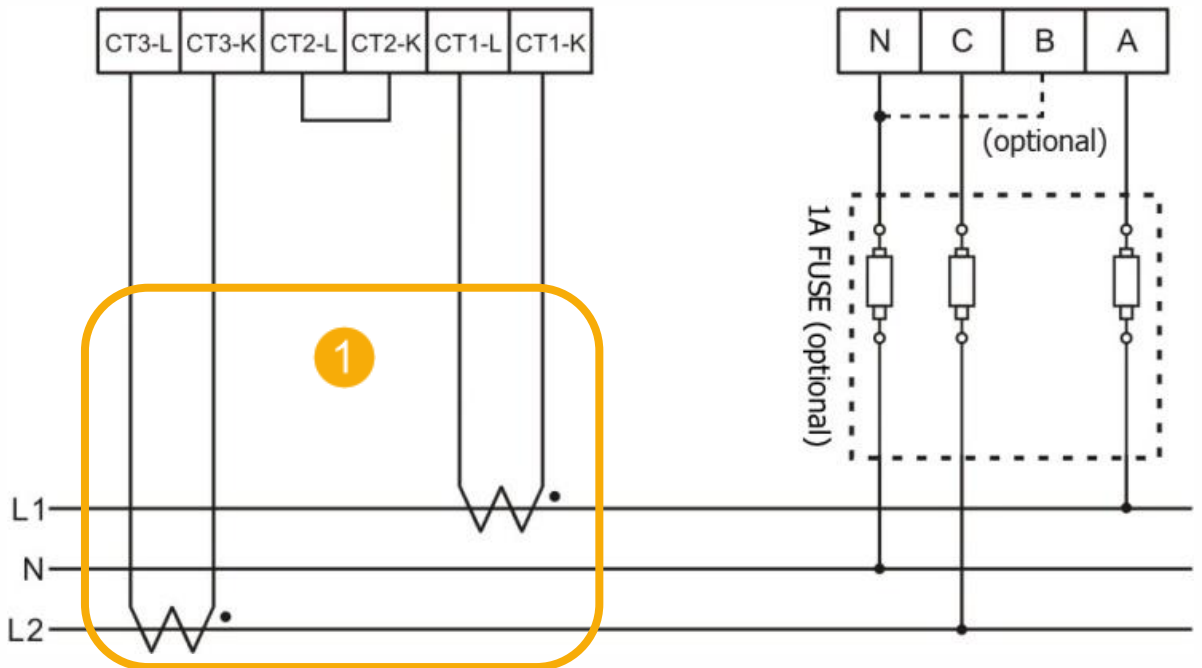

- 3P4W-3CT (Can be configured via software or DIP switch)

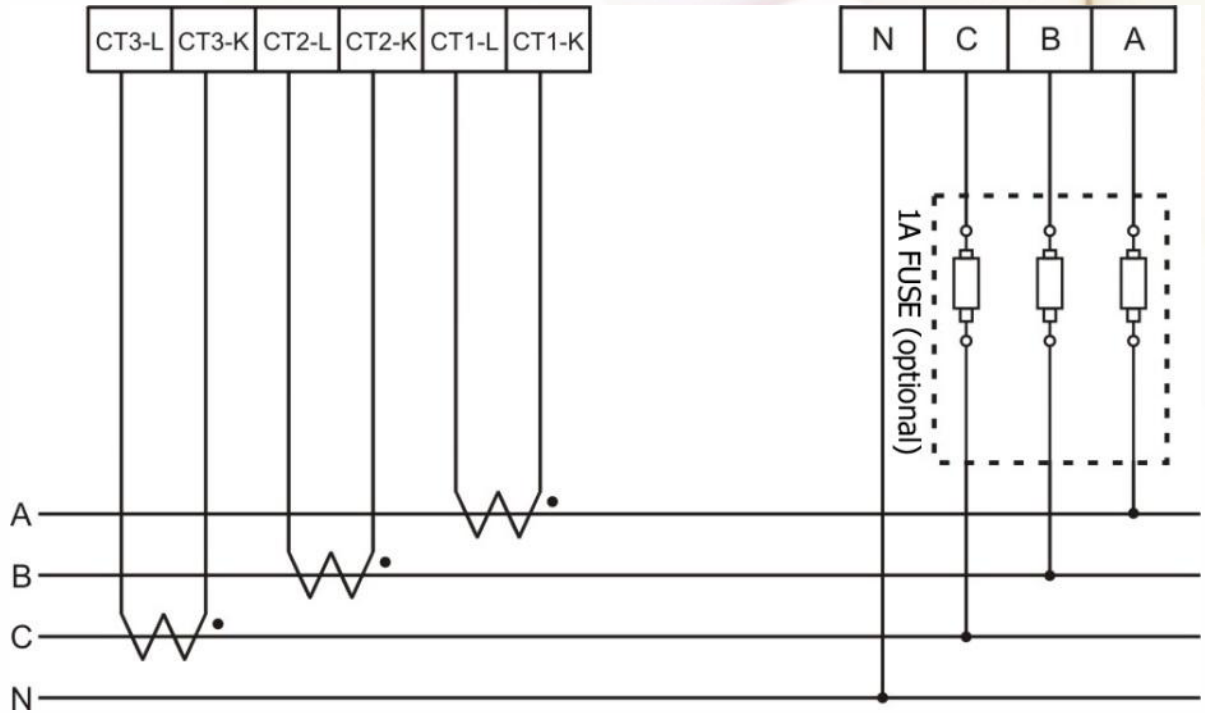

- 3P3W-2CT (Can be configured via software or DIP switch)

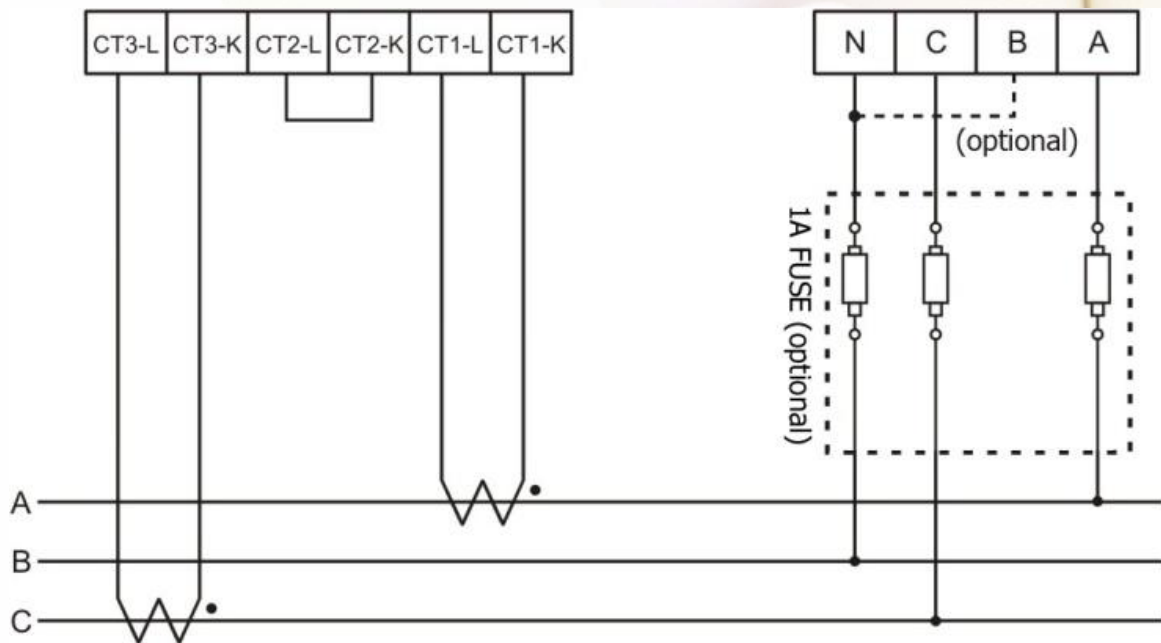

Notes:

1. If phase B is in a floating state, it may pick up induced voltage signals. To avoid this, phase B can be connected to the neutral (N) line.
2. The 3P3W 2CT method is only suitable for **balanced three-phase systems with low harmonic distortion**. For unbalanced loads or systems with significant harmonics, the **3P3W 3CT method** is recommended for accurate measurement. For detailed information, please refer to the Appendix "Questions and Answers" section of the manual.

## 5. Relay Output & LED Indicator

### 5.1. Relay

Relay type	Power Relay, Form A (SPST N.O.)
Operating Voltage Range	250 VAC/30 VDC
Max. Load Current	5 A at 25 °C
Operate Time	6 ms
Release Time	3 ms

### 5.2. LED Indicator

The PM-3133 has 4 LED to indicate the unit's power status, RS-485 communication status, and two DO Relay status.

- **RUN:** Green, LED light up when RS-485 is ready. The LED will flash when the unit is processing RS-485 communication.
- **PWR:** Red, LED stay on when the unit is powered.
- **DO0:** Green, LED DO0 lights up when DO0 is "ON".
- **DO1:** Green, LED DO1 lights up when DO1 is "ON".

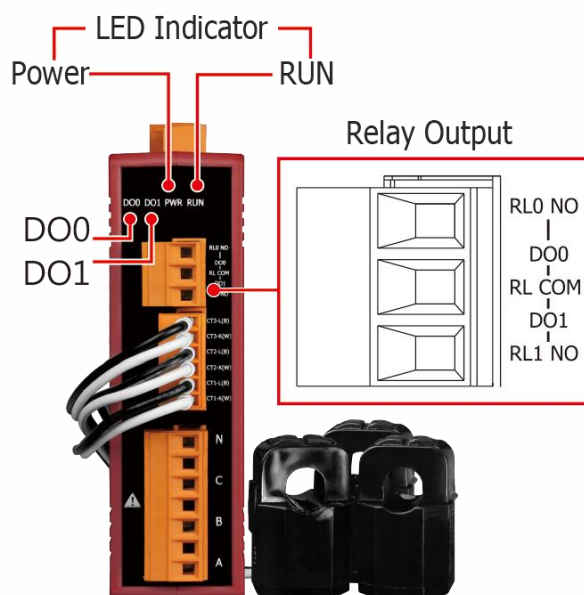

## 6. Modbus-RTU Communication

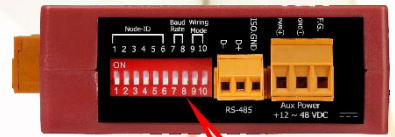

### 6.1. RS-485 Settings

- Default setting for RS-485: **19200, n, 8, 1**
- DIP switch (SW1-SW6): Used for setting the Modbus address, with the default set to 1 (all switches OFF)

For example, to set the Modbus address to 10, configure the DIP switches as follows:

SW1 = ON, SW2 = OFF, SW3 = OFF, SW4 = ON, SW5 = OFF, SW6 = OFF.

- SW1- SW6 Settings

Configure Modbus-RTU communication addresses ranging from 1 to 64. Use the table provided below for specific settings.

Modbus Address	SW 1	SW 2	SW 3	SW 4	SW 5	SW 6
1	OFF	OFF	OFF	OFF	OFF	OFF
2	ON	OFF	OFF	OFF	OFF	OFF
3	OFF	ON	OFF	OFF	OFF	OFF
4	ON	ON	OFF	OFF	OFF	OFF
5	OFF	OFF	ON	OFF	OFF	OFF
6	ON	OFF	ON	OFF	OFF	OFF
7	OFF	ON	ON	OFF	OFF	OFF
8	ON	ON	ON	OFF	OFF	OFF
9	OFF	OFF	OFF	ON	OFF	OFF
10	ON	OFF	OFF	ON	OFF	OFF
11	OFF	ON	OFF	ON	OFF	OFF
12	ON	ON	OFF	ON	OFF	OFF
13	OFF	OFF	ON	ON	OFF	OFF
14	ON	OFF	ON	ON	OFF	OFF
15	OFF	ON	ON	ON	OFF	OFF
16	ON	ON	ON	ON	OFF	OFF
17	OFF	OFF	OFF	OFF	ON	OFF
18	ON	OFF	OFF	OFF	ON	OFF
19	OFF	ON	OFF	OFF	ON	OFF
20	ON	ON	OFF	OFF	ON	OFF
21	OFF	OFF	ON	OFF	ON	OFF
22	ON	OFF	ON	OFF	ON	OFF
23	OFF	ON	ON	OFF	ON	OFF
24	ON	ON	ON	OFF	ON	OFF
25	OFF	OFF	OFF	ON	ON	OFF
26	ON	OFF	OFF	ON	ON	OFF
27	OFF	ON	OFF	ON	ON	OFF

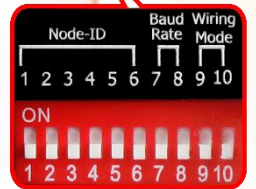

28	ON	ON	OFF	ON	ON	OFF
29	OFF	OFF	ON	ON	ON	OFF
30	ON	OFF	ON	ON	ON	OFF
31	OFF	ON	ON	ON	ON	OFF
32	ON	ON	ON	ON	ON	OFF
33	OFF	OFF	OFF	OFF	OFF	ON
34	ON	OFF	OFF	OFF	OFF	ON
35	OFF	ON	OFF	OFF	OFF	ON
36	ON	ON	OFF	OFF	OFF	ON
37	OFF	OFF	ON	OFF	OFF	ON
38	ON	OFF	ON	OFF	OFF	ON
39	OFF	ON	ON	OFF	OFF	ON
40	ON	ON	ON	OFF	OFF	ON
41	OFF	OFF	OFF	ON	OFF	ON
42	ON	OFF	OFF	ON	OFF	ON
43	OFF	ON	OFF	ON	OFF	ON
44	ON	ON	OFF	ON	OFF	ON
45	OFF	OFF	ON	ON	OFF	ON
46	ON	OFF	ON	ON	OFF	ON
47	OFF	ON	ON	ON	OFF	ON
48	ON	ON	ON	ON	OFF	ON
49	OFF	OFF	OFF	OFF	ON	ON
50	ON	OFF	OFF	OFF	ON	ON
51	OFF	ON	OFF	OFF	ON	ON
52	ON	ON	OFF	OFF	ON	ON
53	OFF	OFF	ON	OFF	ON	ON
54	ON	OFF	ON	OFF	ON	ON
55	OFF	ON	ON	OFF	ON	ON
56	ON	ON	ON	OFF	ON	ON
57	OFF	OFF	OFF	ON	ON	ON
58	ON	OFF	OFF	ON	ON	ON
59	OFF	ON	OFF	ON	ON	ON
60	ON	ON	OFF	ON	ON	ON
61	OFF	OFF	ON	ON	ON	ON
62	ON	OFF	ON	ON	ON	ON
63	OFF	ON	ON	ON	ON	ON
64	ON	ON	ON	ON	ON	ON

● SW7 - SW8 Settings

PM-3133: For Baud Rate Setting

Baud Rate	SW 7	SW 8
9600 bps	OFF	OFF
19200 bps (Default)	<b>ON</b>	OFF
38400 bps	OFF	<b>ON</b>
115200 bps	<b>ON</b>	<b>ON</b>

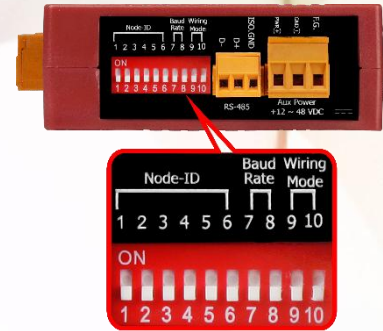

**Note: For a stable signal on the RS-485 Network, it is recommended to add a bias resistor.** The RS-485 master must provide the bias for PM-3133 series or you can add a tM-SG4 or SG-785 to provide the bias. All ICP DAS controllers and converters are equipped with a built-in bias resistor.

## 6.2. Modbus-RTU Setting

### 6.2.1. Specifications

Protocol	Modbus-RTU
Transmission Specifications	Bits per Byte : 1 start bit 8 data bits, least significant bit sent first no parity 1 stop bits Error Check : Cyclical Redundancy Check (CRC)
Baud Rate	9600, 19200 (Default), 38400, 115200
Modbus slave address	1 to 64 (Default is 1)

- **Data format**

**Integer:** 16 bits with sign, occupying 1 register per integer.

**Unsigned Integer:** 16 bits without sign, occupying 1 register per integer.

**Float:** IEEE 754 Format, occupying 2 registers, with the low word transmitted first.

**IEEE 754 Format**

Definition of the floating format of the Bits

Data Hi Word , Hi Byte	Data Hi Word , Lo Byte	Data Lo Word , Hi Byte	Data Lo Word , Lo Byte
SEEE EEEE	EMMM MMMM	MMMM MMMM	MMMM MMMM

Value =  $(-1)^S \times (1.M) \times 2^{E-127}$ , where  $0 < E < 255$ **S:** Sign bit, where 1 is negative and 0 is positive**E:** Exponent with an offset of 127, representing the power of two.

For example, an exponent of zero is represented by the value 127, and an exponent of 1 is represented by the value 128, and so on.

**M:** Mantissa(23-bit), which represents the fractional part of the number. The highest bit, also known as the implicit leading bit, is always assumed to be 1 and is therefore not stored.

Transfer sequence (Float)

1	2	3	4
Data Low Word, High Byte	Data Low Word, Low Byte	Data High Word, High Byte	Data High Word, Low Byte

●

Transfer sequence (Inverse Integer)

1	2	3	4
Data High Word, High Byte	Data High Word, Low Byte	Data Low Word, High Byte	Data Low Word, Low Byte

Transfer sequence (Integer)

1	2	3	4
Data Low Word, High Byte	Data Low Word, Low Byte	Data High Word, High Byte	Data High Word, Low Byte

## 6.2.2. Modbus Register

- Modbus Table #1 – Coil: Relay Value

Parameter Name	Modbus Register		Len	Data Type	Range	Default Value	Comment
	Modicon Format (Base 1)	Hex (Base 0)					
DO 0	04097	0x1000	Word	Byte	0 = OFF 1 = ON	0	
DO 1	04098	0x1001	Word	Byte	0 = OFF 1 = ON	0	
DO 0 Power On Value	04113	0x1010	Word	Byte	0 = OFF 1 = ON	0	
DO 1 Power On Value	04114	0x1011	Word	Byte	0 = OFF 1 = ON	0	

- Modbus Table #2 – Coil: System Boolean Setting Value

Parameter Name	Modbus Register		Len	Data Type	Range	Default Value	Comment
	Modicon Format	Hex					
Enable VLL Compensation	00001	0x0000	Word	Byte	0 = OFF 1 = ON	0	Only work for 3P3W3CT wiring
Disable HW Wiring Dipswitch	00002	0x0001	Word	Byte	0 = OFF 1 = ON	0	[sw9,sw10] always in software mode
Enable Phase B Zero Voltage	00003	0x0002	Word	Byte	0 = OFF 1 = ON	0	Refer to Q18

● Modbus Table #3 – Holding Register: System Parameter Setting

Parameter Name	Modbus Register		Len	Data Type	Range	Default Value	Units	Comment
	Modicon Format	Hex						
Parity	44098	0x1001	Word	UInt	0: None 1: Odd Parity 2: Even Parity	0		Only work for RS-485 Interface
Stop Bit	44099	0x1002	Word	UInt	1: 1 stop bit 2: 2 stop bits	1		Only work for RS-485 Interface
PT_Ratio	44100	0x1003	Word	UInt	1-65535	100	0.01	
CT_Ratio	44101	0x1004	Word	UInt	1-65535	1	1	
Wiring Mode	44107	0x100A	Word	UInt	1: 1P2W 2: 1P3W 3: 3P3W2CT 4: 3P3W3CT 5: 3P4W3CT	5		Only work when SW9-SW10 is all off
Set Energy to Zero	44108	0x100B	Word	UInt	0x0055			Only Write
Reset to Factory Settings	44109	0x100C	Word	UInt	0x0055			Only Write, Re-power the module after setting
Default Frequency	44110	0x100D	Word	UInt	0x0055: Auto 0x0064: 50Hz 0x0078: 60Hz	0x0055		Re-power the module after setting or changing the frequency
Energy Absolute Accumulated Mode	44113	0x1010	Word	UInt	0: Enable 1: Disable	0		
Harmonic Phase Select	44114	0x1011	Word	UInt	0: Disable 1: Phase A 2: Phase B 3: Phase C	0		

Display Voltage	44115	0x1012	Word	UInt	0: Default 1: Show as VIn 2: Show as VII	0		Refer to Q12
CT Ratio Scale	44122	0x1019	Word	UInt	6~10~14	10		Refer to Q14
Max Value of Accumulated Energy	44131	0x1022	Word	UInt	0: 9999999.9 1: 99999999.9 2: 999999999.9	0		
PT Ratio Scale	44132	0x1023	Word	UInt	6~10~14	8		Refer to Q14

## ● Modbus Table #4 – Input Register: System Information

Parameter Name	Modbus Register		Len	Data Type	Range	Default Value	Units	Comment
	Modicon Format	Hex						
Wiring Type	30513	0x0200	Word	UInt	9: 1P2W 10: 1P3W 11: 3P3W2CT 12: 3P3W3CT 13: 3P4W 14: 3P3W2CT (HW) 15: 3P3W3CT (HW) 16: 3P4W (HW)	13		(HW): set wiring by hardware Dip Switch
Phase Sequence	30514	0x0201	Word	UInt	0: Negative (ACB) 1: Positive (ABC) 2: Not Ready			Only work when 3P4W
Model Name	30515	0x0202	Word	UInt	3133: PM-3133	3133		
Model Type	30516	0x0203	Word	UInt	0x0001: 50Hz 0x0002: 60Hz	0x0002		
Firmware Version	30517	0x0204	Word	BCD		0x0100		Ver. 1.0

## ● Modbus Table #5 – Input Register: Power value (Float)

Parameter Name	Modbus Register		Len	Data Type	Range	Units	Comment
	Modicon Format	Hex					
V_a	34353-34354	0x1100-0x1101	DWord	Float		Volt	Refer to Q12
I_a	34355-34356	0x1102-0x1103	DWord	Float		Amp	
kW_a	34357-34358	0x1104-0x1105	DWord	Float		kW	
kvar_a	34359-34360	0x1106-0x1107	DWord	Float		kvar	
kVA_a	34361-34362	0x1108-0x1109	DWord	Float		kVA	
PF_a	34363-34364	0x110A-0x110B	DWord	Float	0~1		
kWh_a	34365-34366	0x110C-0x110D	DWord	Float			±0~9999999.9
kvarh_a	34367-34368	0x110E-0x110F	DWord	Float			±0~9999999.9
kVAh_a	34369-34370	0x1110-0x1111	DWord	Float			±0~9999999.9
V_b	34371-34372	0x1112-0x1113	DWord	Float		Volt	Refer to Q12
I_b	34373-34374	0x1114-0x1115	DWord	Float		Amp	
kW_b	34375-34376	0x1116-0x1117	DWord	Float		kW	
kvar_b	34377-34378	0x1118-0x1119	DWord	Float		kvar	
kVA_b	34379-34380	0x111A-0x111B	DWord	Float		kVA	
PF_b	34381-34382	0x111C-0x111D	DWord	Float	0~1		
kWh_b	34383-34384	0x111E-0x111F	DWord	Float			
kvarh_b	34385-34386	0x1120-0x1121	DWord	Float			
kVAh_b	34387-34388	0x1122-0x1123	DWord	Float			
V_c	34389-34390	0x1124-0x1125	DWord	Float		Volt	Refer to Q12
I_c	34391-34392	0x1126-0x1127	DWord	Float		Amp	
kW_c	34393-34394	0x1128-0x1129	DWord	Float		kW	
kvar_c	34395-34396	0x112A-0x112B	DWord	Float		kvar	
kVA_c	34397-34398	0x112C-0x112D	DWord	Float		kVA	
PF_c	34399-34400	0x112E-0x112F	DWord	Float	0~1		
kWh_c	34401-34402	0x1130-0x1131	DWord	Float			
kvarh_c	34403-34404	0x1132-0x1133	DWord	Float			
kVAh_c	34405-34406	0x1134-0x1135	DWord	Float			
V_avg	34407-34408	0x1136-0x1137	DWord	Float		Volt	
I_avg	34409-34410	0x1138-0x1139	DWord	Float		Amp	
kW_tot	34411-34412	0x113A-0x113B	DWord	Float		kW	
kvar_tot	34413-34414	0x113C-0x113D	DWord	Float		kvar	
kVA_tot	34415-34416	0x113E-0x113F	DWord	Float		kVA	

PF_tot	34417-34418	0x1140-0x1141	DWord	Float	0~1		
kWh_tot	34419-34420	0x1142-0x1143	DWord	Float			
kvarh_tot	34421-34422	0x1144-0x1145	DWord	Float			
kVAh_tot	34423-34424	0x1146-0x1147	DWord	Float			
Freq_a	34425-34426	0x1148-0x1149	DWord	Float	45~65	Hz	
Freq_b	34427-34428	0x114A-0x114B	DWord	Float	45~65	Hz	
Freq_c	34429-34430	0x114C-0x114D	DWord	Float	45~65	Hz	
Freq_max	34431-34432	0x114E-0x114F	DWord	Float	45~65	Hz	
VTHD	34459-34460	0x116A-0x116B	DWord	Float			Phase set by <b>Harmonic Phase Select</b> Register
ITHD	34461-34462	0x116C-0x116D	DWord	Float			
Bi_Positive_kWh	34463-34464	0x116E-0x116F	DWord	Float			
Bi_Negative_kWh	34465-34466	0x1170-0x1171	DWord	Float			
Bi_Net_kWh	34467-34468	0x1172-0x1173	DWord	Float			
Bi_Total_kWh	34469-34470	0x1174-0x1175	DWord	Float			
Signed PF_A	34515-34516	0x11A2-0x11A3	DWord	Float	-2~+2		Refer to Q15
Signed PF_B	34517-34518	0x11A4-0x11A5	DWord	Float	-2~+2		Refer to Q15
Signed PF_C	34519-34520	0x11A6-0x11A7	DWord	Float	-2~+2		Refer to Q15
Signed PF_Total	34521-34522	0x11A8-0x11A9	DWord	Float	-2~+2		Refer to Q15

**Note:**

The definition of bi-direction energy registers:

- **Bi\_Positive\_kWh:** = Sum( absolute( all channel's positive kWh in every sec.))
- **Bi\_Negative\_kWh:** = Sum( absolute( all channel's negative kWh in every sec.))
- **Bi\_Net\_kWh:** = Sum( all channel's kWh in every sec. )
- **Bi\_Total\_kWh:** = Sum( absolute( all channels kWh in every sec. ))

## ● Modbus Table #6 – Input Register: Power value (Inverse Integer)

Parameter Name	Modbus Register		Len	Data Type	Range	Units	Comment
	Modicon Format	Hex					
V_a	34609- 34610	0x1200-0x1201	DWord	UInt32		0.1 Volt	
I_a	34611- 34612	0x1202-0x1203	DWord	UInt32		0.1A	
kW_a	34613- 34614	0x1204-0x1205	DWord	Int32		0.1kW	
kvar_a	34615- 34616	0x1206-0x1207	DWord	Int32		0.1kvar	
kVA_a	34617- 34618	0x1208-0x1209	DWord	Int32		0.1kVA	
PF_a	34619	0x120A	Word	Int	0~1000	0.001PF	0~1.000
kWh_a	34620- 34621	0x120B-0x120C	DWord	Int32	±0~99999999	0.1kWh	±0~9999999.9
kvarh_a	34622- 34623	0x120D-0x120E	DWord	Int32	±0~99999999	0.1kvarh	±0~9999999.9
kVAh_a	34624- 34625	0x120F-0x1210	DWord	Int32	0~99999999	0.1kVAh	0~9999999.9
V_b	34626- 34627	0x1211-0x1212	DWord	UInt32		0.1 Volt	
I_b	34628- 34629	0x1213-0x1214	DWord	UInt32		0.1A	
kW_b	34630- 34631	0x1215-0x1216	DWord	Int32		0.1kW	
kvar_b	34632- 34633	0x1217-0x1218	DWord	Int32		0.1kvar	
kVA_b	34634- 34635	0x1219-0x121A	DWord	Int32		0.1kVA	
PF_b	34636	0x121B	Word	Int	0~1000	0.001PF	0~1.000
kWh_b	34637- 34638	0x121C-0x121D	DWord	Int32	±0~99999999	0.1kWh	±0~9999999.9
kvarh_b	34639- 34640	0x121E-0x121F	DWord	Int32	±0~99999999	0.1kvarh	±0~9999999.9
kVAh_b	34641- 34642	0x1220-0x1221	DWord	Int32	0~99999999	0.1kVAh	0~9999999.9
V_c	34643- 34644	0x1222-0x1223	DWord	UInt32		0.1 Volt	
I_c	34645- 34646	0x1224-0x1225	DWord	UInt32		0.1A	
kW_c	34647- 34648	0x1226-0x1227	DWord	Int32		0.1kW	
kvar_c	34649- 34650	0x1228-0x1229	DWord	Int32		0.1kvar	
kVA_c	34651- 34652	0x122A-0x122B	DWord	Int32		0.1kVA	
PF_c	34653	0x122C	Word	Int	0~1000	0.001PF	0~1.000
kWh_c	34654- 34655	0x122D-0x122E	DWord	Int32	±0~99999999	0.1kWh	±0~9999999.9
kvarh_c	34656-34657	0x122F-0x1230	DWord	Int32	±0~99999999	0.1kvarh	±0~9999999.9
kVAh_c	34658-34659	0x1231-0x1232	DWord	Int32	0~99999999	0.1kVAh	0~9999999.9
V_avg	34660-34661	0x1233-x1234	DWord	UInt32		0.1 Volt	
I_avg	34662-34663	0x1235-0x1236	DWord	UInt32		0.1A	
kW_tot	34664-34665	0x1237-0x1238	DWord	Int32		0.1kW	
kvar_tot	34666-34667	0x1239-0x123A	DWord	Int32		0.1kvar	
kVA_tot	34668-34669	0x123B-0x123C	DWord	Int32		0.1kVA	

PF_tot	34670	0x123D	Word	Int	0~1000	0.001PF	0~1.000
kWh_tot	34671-34672	0x123E-0x123F	DWord	Int32	±0~99999999	0.1kWh	±0~9999999.9
kvarh_tot	34673-34674	0x1240-0x1241	DWord	Int32	±0~99999999	0.1kvarh	±0~9999999.9
kVAh_tot	34675-34676	0x1242-0x1243	DWord	Int32	0~99999999	0.1kVAh	0~9999999.9
Freq_a	34677	0x1244	Word	Int	45~65	1Hz	45~65
Freq_b	34678	0x1245	Word	Int	45~65	1Hz	45~65
Freq_c	34679	0x1246	Word	Int	45~65	1Hz	45~65
Freq_max	34680	0x1247	Word	Int	45~65	1Hz	45~65

## ● Modbus Table #7 – Input Register: Power value (Integer)

Parameter Name	Modbus Register		Len	Data Type	Range	Units	Comment
	Modicon Format	Hex					
V_a	34865-34866	0x1300-0x1301	DWord	UInt32		0.1 Volt	
I_a	34867-34868	0x1302-0x1303	DWord	UInt32		0.1A	
kW_a	34869-34870	0x1304-0x1305	DWord	Int32		0.1kW	
kvar_a	34871-34872	0x1306-0x1307	DWord	Int32		0.1kvar	
kVA_a	34873-34874	0x1308-0x1309	DWord	Int32		0.1kVA	
PF_a	34875	0x130A	Word	Int	0~1000	0.001PF	0~1.000
kWh_a	34876-34877	0x130B-0x130C	DWord	Int32	±0~99999999	0.1kWh	±0~9999999.9
kvarh_a	34878-34879	0x130D-0x130E	DWord	Int32	±0~99999999	0.1kvarh	±0~9999999.9
kVAh_a	34880-34881	0x130F-0x1310	DWord	Int32	0~99999999	0.1kVAh	0~9999999.9
V_b	34882-34883	0x1311-0x1312	DWord	UInt32		0.1 Volt	
I_b	34884-34885	0x1313-0x1314	DWord	UInt32		0.1A	
kW_b	34886-34887	0x1315-0x1316	DWord	Int32		0.1kW	
kvar_b	34888-34889	0x1317-0x1318	DWord	Int32		0.1kvar	
kVA_b	34890-34891	0x1319-0x131A	DWord	Int32		0.1kVA	
PF_b	34892	0x131B	Word	Int	0~1000	0.001PF	0~1.000
kWh_b	34893-34894	0x131C-0x131D	DWord	Int32	±0~99999999	0.1kWh	±0~9999999.9
kvarh_b	34895-34896	0x131E-0x131F	DWord	Int32	±0~99999999	0.1kvarh	±0~9999999.9
kVAh_b	34897-34898	0x1320-0x1321	DWord	Int32	0~99999999	0.1kVAh	0~9999999.9
V_c	34899-34900	0x1322-0x1323	DWord	UInt32		0.1 Volt	
I_c	34901-34902	0x1324-0x1325	DWord	UInt32		0.1A	
kW_c	34903-34904	0x1326-0x1327	DWord	Int32		0.1kW	
kvar_c	34905-34906	0x1328-0x1329	DWord	Int32		0.1kvar	
kVA_c	34907-34908	0x132A-0x132B	DWord	Int32		0.1kVA	
PF_c	34909	0x132C	Word	Int	0~1000	0.001PF	0~1.000
kWh_c	34910-34911	0x132D-0x132E	DWord	Int32	±0~99999999	0.1kWh	±0~9999999.9
kvarh_c	34912-34913	0x132F-0x1330	DWord	Int32	±0~99999999	0.1kvarh	±0~9999999.9
kVAh_c	34914-34915	0x1331-0x1332	DWord	Int32	0~99999999	0.1kVAh	0~9999999.9
V_avg	34916-34917	0x1333-0x1334	DWord	UInt32		0.1 Volt	
I_avg	34918-34919	0x1335-0x1336	DWord	UInt32		0.1A	
kW_tot	34920-34921	0x1337-0x1338	DWord	Int32		0.1kW	

kvar_tot	34922-34923	0x1339-0x133A	DWord	Int32		0.1kvar	
kVA_tot	34924-34925	0x133B-0x133C	DWord	Int32		0.1kVA	
PF_tot	34926	0x133D	Word	Int	0~1000	0.001PF	0~1.000
kWh_tot	34927-34928	0x133E-0x133F	DWord	Int32	±0~99999999	0.1kWh	±0~9999999.9
kvarh_tot	34929-34930	0x1340-0x1341	DWord	Int32	±0~99999999	0.1kvarh	±0~9999999.9
kVAh_tot	34931-34932	0x1342-0x1343	DWord	Int32	0~99999999	0.1kVAh	0~9999999.9
Freq_a	34933	0x1344	Word	Int	45~65	1Hz	45~65
Freq_b	34934	0x1345	Word	Int	45~65	1Hz	45~65
Freq_c	34935	0x1346	Word	Int	45~65	1Hz	45~65
Freq_max	34936	0x1347	Word	Int	45~65	1Hz	45~65

## 7. Modbus-TCP Communication

### 7.1. Default Settings

Ethernet default settings:

<b>IP Address</b>	<b>192.168.255.1</b>
<b>Subnet mask</b>	<b>255.255.0.0</b>
<b>Gateway</b>	<b>192.168.0.1</b>
<b>Port</b>	<b>502</b>

To restore the default settings, set the **Init/Run Switch (SW 4)** to the **Init** position for 10 seconds after powering on. The settings will reset to their default values. After the reset, switch back to the **Run** position and power on again.

Alternatively, users can restore the default settings using a **Modbus command**.

Alternatively, users can restore the default settings using a **Modbus command**.

- SW1- SW2 Settings

For the PM-3133, select the appropriate wiring mode:

(use the Software setting for 1P2W-1CT or 1P3W-2CT)

Wiring	SW 1	SW 2
Software setting	OFF	OFF
3P3W-2CT	ON	OFF
3P3W-3CT	OFF	ON
3P4W-3CT	ON	ON



## 7.1.1. Ethernet Configurations

In the **Power Meter Utility**, select “**Modbus TCP**” under the **Communication Interface**.

Connection Setting Languages: En 繁 简

Communication Interface:  Modbus RTU  **Modbus TCP/EIP**

IP: . . . : 502 Search Timeout: 1500 ms Meter ID: 1 Connect

Click “**Search**” to access the “**Communication Interface Setting**” window.

Connection Setting Languages: En 繁 简

Communication Interface:  Modbus RTU  Modbus TCP/EIP

IP: . . . : 502 Search Timeout: 1500 ms Meter ID: 1 Connect

Click “**Search**” button to locate available power meter.

Communication Interface Setting

Please Select Modbus TCP Power Meter Device

Name	Alias	IP Address	Subnet Mask	Gateway	MAC Address	DHCP
PM-3133	PM-xxxx	192.168.100.165	255.255.255.0	192.168.100.254	00:0d:e0:b1:ee:77	ON
PM-3033	PM-x2159	192.168.100.215	255.255.255.0	192.168.100.254	00:0d:e0:b1:00:0a	ON

Search Configuration OK Cancel

Select the power meter you want to configure from the list, then click the **“Configuration”** button to adjust the meter parameters. After completing all settings, click **“OK”** to return to the meter list window.

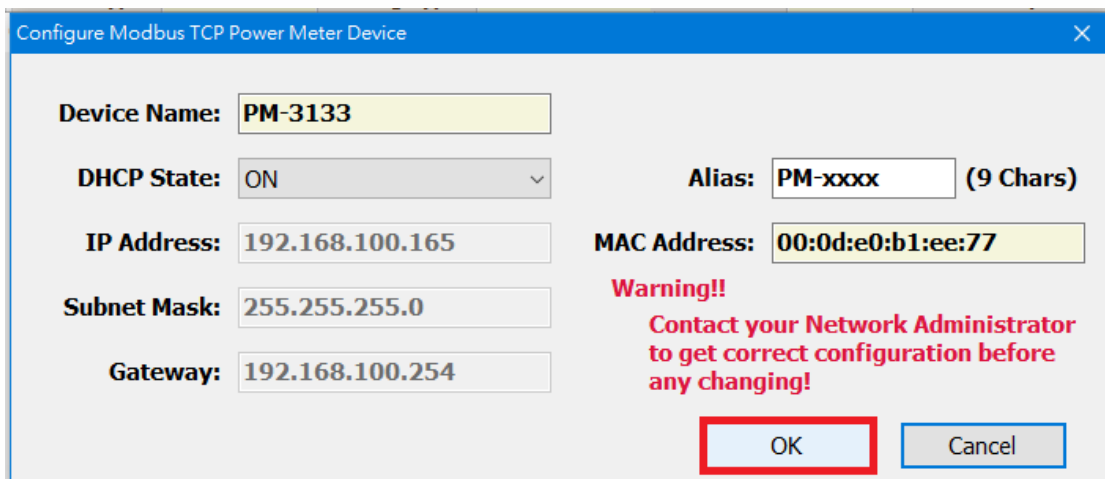
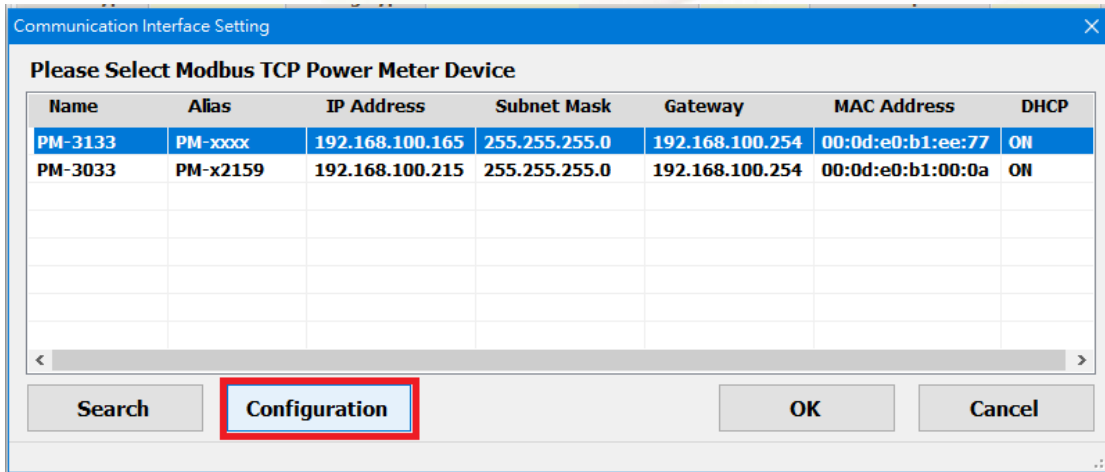

## 7.2. Connecting the Power Meter and Host PC

### 7.2.1. Without PoE (Power over Ethernet)

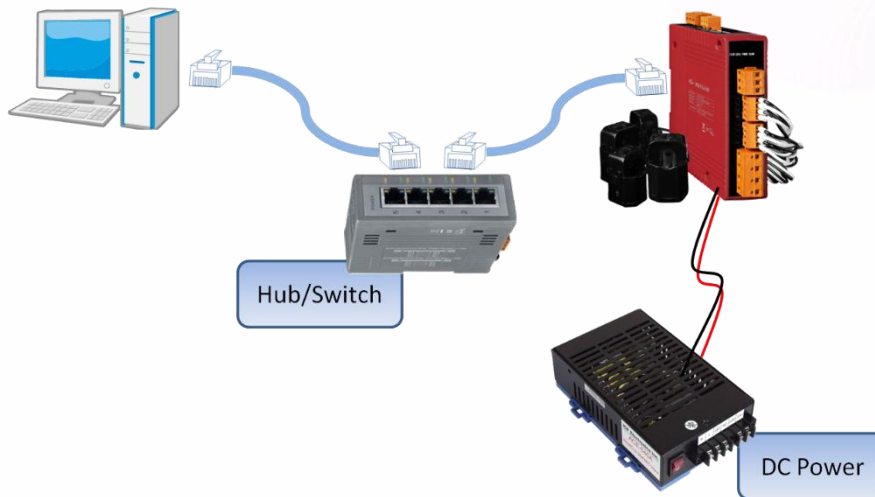

### 7.2.2. With PoE (Power over Ethernet)

The PM-3133-xxx-MTCP module can be powered by an **IEEE802.3af** compliant PoE switch. Both Ethernet and power can be carried by an Ethernet cable eliminating the need for additional wiring and power supply.



## 8. EtherNet/IP Communication

### 8.1. Default Settings

Default settings:

IP Address	192.168.255.1
Subnet mask	255.255.0.0
Gateway	192.168.0.1

To restore the default settings, set the **Init/Run Switch (SW 4)** to **Init** position for 10 seconds after powering on. The settings will reset to their default values. After the reset, switch back to the **Run** position and power on again.

- SW1- SW2 Settings

For the PM-3133, select the appropriate wiring mode

Wiring	SW 1	SW 2
Software setting	OFF	OFF
3P3W-2CT	<b>ON</b>	OFF
3P3W-3CT	OFF	<b>ON</b>
3P4W-3CT	<b>ON</b>	<b>ON</b>

(use the Software setting for 1P2W-1CT or 1P3W-2CT)



#### 8.1.1. Utility configurations

The PM-3133-EIP power meter modules can be configured using the Power Meter Utility. For detailed instructions on how to use the utility, please refer to section 7.1.1.

## 8.2. EtherNet/IP Protocol

The power meter provides an EtherNet/IP adapter function. This section introduces the power meter's EtherNet/IP Object Model and explains how to read from and write to the power meter by using the Explicit and Implicit Messages through the EtherNet/IP protocol.

### 8.2.1. Object Model

The EtherNet/IP adapter of the power meter provides six different objects, each serving specific functions with defined characteristics, services and instances:

- **Connection Manager Object:**  
Manages the establishment and maintenance of connections, handling the transmission of Explicit Messages and Implicit Messages.
- **Message Router Object:**  
Routes incoming messages to the correct object within the EtherNet/IP adapter for processing based on the target object ID and instance ID.
- **Assembly Object:**  
Organizes and manages I/O data by packaging multiple I/O data points into a structured data collection, facilitating efficient data transmission and exchange.
- **Identity Object:**  
Stores basic device information such as device identification, model, serial number, and status, aiding in device recognition and management.
- **TCP/IP Object:**  
Handles TCP/IP settings, including network parameters like IP address, subnet mask, and gateway configuration.
- **Ethernet Link Object:**  
Monitors and manages the status of the Ethernet connection, including link speed, connection status, and error statistics.

When the power meter receives an EtherNet/IP message, it determines whether it is an Explicit or Implicit Message:

- **Explicit Messages** can either access the Assembly Object directly or reach other objects via the Message Router Object.
- **Implicit Messages** are limited to accessing I/O data from the Assembly Object.

#### **Unconnected Message Manager(UCMM)**

- UCMM messages allow communication with any object without establishing a connection.
- When a UCMM message is received, it is routed via the Message Router Object.
- During communication between an EtherNet/IP scanner and the power meter's EtherNet/IP adapter, the power meter responds with the appropriate data based on the request.

## 8.2.2. Explicit Message

Explicit Messages are used to access all objects within the object model. Before sending Explicit Messages, a connection must be established. The process is as follows:

### 1. Connection Establishment:

- Use the **Forward Open** service of the **Connection Manager Object** to establish the connection.
- This service ensures a stable communication link between the scanner and the power meter.

### 2. Data Transmission:

- Once the connection is established, the scanner can use Explicit Messages to perform read or write operations on the power meter's objects.
- For example, it can read voltage values from the power meter or configure certain parameters.

## 8.2.3. Implicit Message

Implicit Messages are used specifically for high real-time data exchange requirements.

The main features are as follows:

### 1. Purpose:

- Implicit Messages are specifically used to access the Input Instance (65<sub>hex</sub>) and Output Instance (66<sub>hex</sub>) of the Assembly Object, enabling real-time I/O data exchange.

### 2. Connection Establishment:

- Similar to Explicit Messages, Implicit Messages also require a connection to be established before use.
- The Forward Open service of the Connection Manager Object must be used to establish the connection between the EtherNet/IP scanner and the power meter. Once the connection is established, the scanner can start transmitting Implicit Messages.

### 3. Data Format:

- All data in the Input and Output Instances is structured in BYTE format.
- Regardless of whether the original data format is 1-bit, WORD, or another type, all register data is allocated to the Assembly Object's Instances in BYTE format.

### 4. Instance IDs and Data Sizes:

- The **PM-3133-EIP** instance ID and their corresponding data sizes are as follows:

Implicit Message Information		
Name	Instance ID	Data Length
Input(T->O)	65 <sub>hex</sub> (101)	168
Output(O->T)	66 <sub>hex</sub> (102)	7
Configuration	64 <sub>hex</sub> (100)	0

## 8.2.4. Power Meter Data Frame

The power meter measurements are represented as floating-point values. Each float value is encoded using a 4-byte hexadecimal format(Hex value).

For example, if the float value is 1.234, the corresponding hexadecimal value would be 0x3F9DF3B6. This 4-byte Hex value is transmitted as a byte array in the following format:

<b>Float value</b>		<b>1.234</b>
<b>Hex value</b>		0x3F9DF3B6
<b>Byte Array</b>	Byte 1	0xB6
	Byte 2	0xF3
	Byte 3	0x9D
	Byte 4	0x3F

The EherNet/IP input data frame:

Float format		
Item	Description	Byte index
V_a	Phase A VRMS	1
		2
		3
		4
I_a	Phase A IRMS	5
		6
		7
		8
kW_a	Phase A kWatt	9
		10
		11
		12
kvar_a	Phase A kvar	13
		14
		15
		16
kVA_a	Phase A kVA	17
		18
		19
		20

<b>PF_a</b>	Phase A PF	21
		22
		23
		24
<b>kWh_a</b>	Phase A kWh	25
		26
		27
		28
<b>kvarh_a</b>	Phase A kvarh	29
		30
		31
		32
<b>kVAh_a</b>	Phase A kVAh	33
		34
		35
		36
<b>FREQ_a</b>	Phase A Frequency	37
		38
		39
		40
<b>V_b</b>	Phase B VRMS	41
		42
		43
		44
<b>I_b</b>	Phase B IRMS	45
		46
		47
		48
<b>kW_b</b>	Phase B kWatt	49
		50
		51
		52
<b>kvar_b</b>	Phase B kvar	53
		54
		55
		56

<b>kVA_b</b>	Phase B kVA	57
		58
		59
		60
<b>PF_b</b>	Phase B PF	61
		62
		63
		64
<b>kWh_b</b>	Phase B kWh	65
		66
		67
		68
<b>kvarh_b</b>	Phase B kvarh	69
		70
		71
		72
<b>kVAh_b</b>	Phase B kVAh	73
		74
		75
		76
<b>FREQ_b</b>	Phase B Frequency	77
		78
		79
		80
<b>V_c</b>	Phase C VRMS	81
		82
		83
		84
<b>I_c</b>	Phase C IRMS	85
		86
		87
		88
<b>kW_c</b>	Phase C kWatt	89
		90
		91
		92

<b>kvar_c</b>	Phase C kvar	93
		94
		95
		96
<b>kVA_c</b>	Phase C kVA	97
		98
		99
		100
<b>PF_c</b>	Phase C PF	101
		102
		103
		104
<b>kWh_c</b>	Phase C kWh	105
		106
		107
		108
<b>kvarh_c</b>	Phase C kvarh	109
		110
		111
		112
<b>kVAh_c</b>	Phase C kVAh	113
		114
		115
		116
<b>FREQ_c</b>	Phase C Frequency	117
		118
		119
		120
<b>VTHD</b>	Voltage total harmonic distortion	121
		122
		123
		124
<b>ITHD</b>	Current total harmonic distortion	125
		126
		127
		128

<b>kW_tot</b>	Total kWatt	129
		130
		131
		132
<b>kWh_tot</b>	Total kWh	133
		134
		135
		136
<b>PF_tot</b>	Total PF	137
		138
		139
		140
<b>V_avg</b>	Average Voltage	141
		142
		143
		144
<b>I_avg</b>	Average Current	145
		146
		147
		148
<b>PT_R</b>	PT Ratio	149
		150
<b>CT_R</b>	CT Ratio	151
		152
<b>WR_M</b>	Wiring Mode	153
	[Note]	154
	1: 1P2W	
	2: 1P3W	
	3: 3P3W2CT	
4: 3P3W3CT		
5: 3P4W3CT		
<b>PH_seq</b>	Phase Sequence	155
		156
<b>MN</b>	Model Name	157
		158
<b>Ver</b>	Firmware Version	159

		160
Reserved	Reserved	161
Reserved	Reserved	162
Reserved	Reserved	163
Reserved	Reserved	164
Reserved	Reserved	165
Reserved	Reserved	166
Reserved	Reserved	167
Reserved	Reserved	168

The EherNet/IP output data frame:

Float format		
Item	Description	Byte index
DO0	Relay 0 [Note] 0 = OFF 1 = ON	1
DO1	Relay 1 [Note] 0 = OFF 1 = ON	2
ENRG_ZERO	Set Energy Zero 0 = OFF 1 = ON	3
Reserved	Reserved	4
Reserved	Reserved	5
Reserved	Reserved	6
Reserved	Reserved	7

## 8.3. Connecting the Power and Host PC

### 8.3.1. Without PoE(Power over Ethernet)

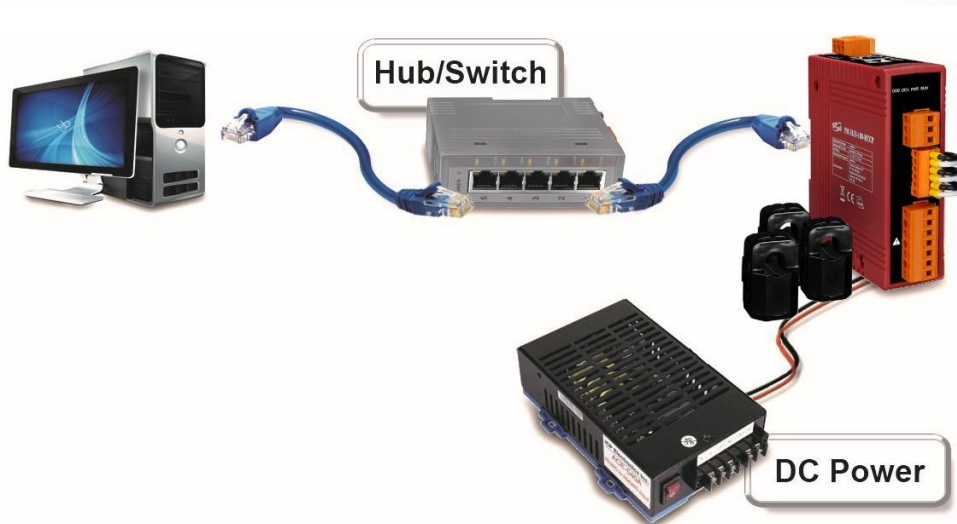

### 8.3.2. With PoE(Power over Ethernet ):

The PM-3133-EIP module can be powered using a PoE switch that complies with the IEEE802.3af standard. This allows both data and power to be transmitted over a single Ethernet cable, eliminating the need for separate power wiring and simplifying installation.



## 9. CANopen Communication

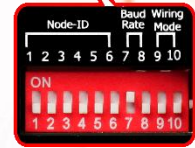

### 9.1. CANopen Settings

- Default setting for CANopen: **Baud rate:125 K b.p.s., Node ID:1**
- DIP switch (SW1-SW6): Used for setting the Node ID, with the default set to 1(all switches OFF)

**For example:** to set the Node ID to 10 , configure the DIP switches as follows:  
SW1 = ON, SW2 = OFF, SW3 = OFF, SW4 = ON, SW5 = OFF, SW6 = OFF.

- SW1 – SW6 Settings

The DIP switches **SW1–SW6** are used to configure the **CANopen Node ID** for communication. The Node ID can be set to any value between **1 and 64**. The table below shows how to configure the DIP switches for each Node ID:

Node ID	SW 1	SW 2	SW 3	SW 4	SW 5	SW 6
1	OFF	OFF	OFF	OFF	OFF	OFF
2	ON	OFF	OFF	OFF	OFF	OFF
3	OFF	ON	OFF	OFF	OFF	OFF
4	ON	ON	OFF	OFF	OFF	OFF
5	OFF	OFF	ON	OFF	OFF	OFF
6	ON	OFF	ON	OFF	OFF	OFF
7	OFF	ON	ON	OFF	OFF	OFF
8	ON	ON	ON	OFF	OFF	OFF
9	OFF	OFF	OFF	ON	OFF	OFF
10	ON	OFF	OFF	ON	OFF	OFF
11	OFF	ON	OFF	ON	OFF	OFF
12	ON	ON	OFF	ON	OFF	OFF
13	OFF	OFF	ON	ON	OFF	OFF
14	ON	OFF	ON	ON	OFF	OFF
15	OFF	ON	ON	ON	OFF	OFF
16	ON	ON	ON	ON	OFF	OFF
17	OFF	OFF	OFF	OFF	ON	OFF
18	ON	OFF	OFF	OFF	ON	OFF
19	OFF	ON	OFF	OFF	ON	OFF
20	ON	ON	OFF	OFF	ON	OFF
21	OFF	OFF	ON	OFF	ON	OFF
22	ON	OFF	ON	OFF	ON	OFF
23	OFF	ON	ON	OFF	ON	OFF
24	ON	ON	ON	OFF	ON	OFF
25	OFF	OFF	OFF	ON	ON	OFF
26	ON	OFF	OFF	ON	ON	OFF

27	OFF	ON	OFF	ON	ON	OFF
28	ON	ON	OFF	ON	ON	OFF
29	OFF	OFF	ON	ON	ON	OFF
30	ON	OFF	ON	ON	ON	OFF
31	OFF	ON	ON	ON	ON	OFF
32	ON	ON	ON	ON	ON	OFF
33	OFF	OFF	OFF	OFF	OFF	ON
34	ON	OFF	OFF	OFF	OFF	ON
35	OFF	ON	OFF	OFF	OFF	ON
36	ON	ON	OFF	OFF	OFF	ON
37	OFF	OFF	ON	OFF	OFF	ON
38	ON	OFF	ON	OFF	OFF	ON
39	OFF	ON	ON	OFF	OFF	ON
40	ON	ON	ON	OFF	OFF	ON
41	OFF	OFF	OFF	ON	OFF	ON
42	ON	OFF	OFF	ON	OFF	ON
43	OFF	ON	OFF	ON	OFF	ON
44	ON	ON	OFF	ON	OFF	ON
45	OFF	OFF	ON	ON	OFF	ON
46	ON	OFF	ON	ON	OFF	ON
47	OFF	ON	ON	ON	OFF	ON
48	ON	ON	ON	ON	OFF	ON
49	OFF	OFF	OFF	OFF	ON	ON
50	ON	OFF	OFF	OFF	ON	ON
51	OFF	ON	OFF	OFF	ON	ON
52	ON	ON	OFF	OFF	ON	ON
53	OFF	OFF	ON	OFF	ON	ON
54	ON	OFF	ON	OFF	ON	ON
55	OFF	ON	ON	OFF	ON	ON
56	ON	ON	ON	OFF	ON	ON
57	OFF	OFF	OFF	ON	ON	ON
58	ON	OFF	OFF	ON	ON	ON
59	OFF	ON	OFF	ON	ON	ON
60	ON	ON	OFF	ON	ON	ON
61	OFF	OFF	ON	ON	ON	ON
62	ON	OFF	ON	ON	ON	ON
63	OFF	ON	ON	ON	ON	ON
64	ON	ON	ON	ON	ON	ON

● SW7 – SW8 Settings

PM-3133: For CANopen Baud Rate Setting

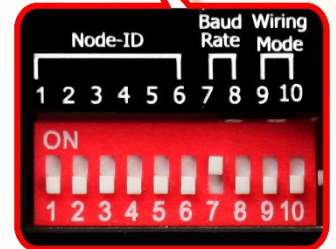
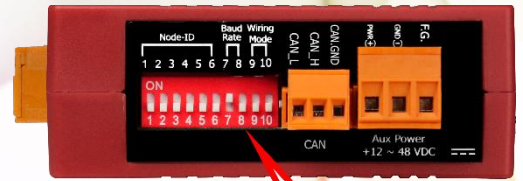

Baud Rate	SW 7	SW8
125 K bps(Default)	OFF	OFF
250 K bps	<b>ON</b>	OFF
500 K bps	OFF	<b>ON</b>
1M bps	<b>ON</b>	<b>ON</b>

## 9.2. CANopen Protocol

CANopen is a network protocol derived from the CAN bus, initially used in automotive control systems. Today, it has been widely adopted in various applications, such as vehicles, industrial machinery, building automation, medical devices, maritime systems, restaurant appliances, laboratory equipment and research applications.

### 9.2.1. SDO Introduction

As one of the core protocols in CANopen, the Service Data Object (SDO) protocol facilitates access to a device's Object Dictionary, allowing for the reading and writing of configuration parameters as well as the exchange of non-real-time data. This protocol plays a critical role in device configuration and diagnostics, serving as the foundation for the detailed communication methods outlined in the subsequent sections. The following sections will provide an in-depth explanation of the specific communication mechanisms of the SDO protocol, including its upload and download processes, as well as the handling of exceptional scenarios such as interrupted transmissions.

#### 9.2.1.1. Upload SDO Protocol

##### Initiate SDO Upload Protocol

Before performing SDO segment transfers, the client and server must establish communication through the **Initiate SDO Upload Protocol**. This protocol allows the SDO client to specify the object to be uploaded to the server and simultaneously transfer up to 4 bytes of data.

- If the data length is less than or equal to 4 bytes:  
The upload is completed using only the Initiate SDO Upload Protocol.
- If the data length is greater than 4 bytes:  
The Upload SDO Segment Protocol is required to transfer the data in smaller parts.

The communication process of this protocol is shown as follows.

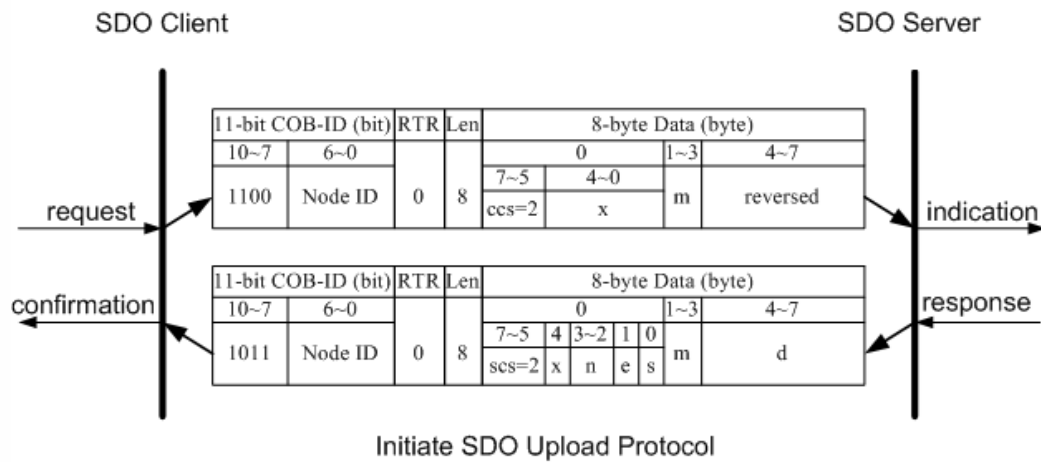

**ccs:** client command specifier

2: initiate upload request

**scs:** server command specifier

2: initiate upload response

**n:** Only valid if **e** = 1 and **s** = 1, otherwise 0.

If this field is valid, **n** represents the number of Bytes in the **d** field that are not used to store segment data. Specifically, the Bytes in the range [8-n, 7] of the **d** field are unused and do not contain any valid data.

**e:** transfer type

0: normal transfer

1: expedited transfer

If **e=1**, it indicates that the data size is less than or equal to 4 bytes. In this case, the transmission can be completed using only the Initiate SDO Upload Protocol.

If **e=0**, the Upload SDO Segment Protocol is required to complete the transmission.

**s:** size indicator

0: Data set size is not indicated.

1: Data set size is indicated.

**m:** multiplexer

It represents the index/sub-index of the data to be transferred by the SDO. The first two bytes are the index value and the last byte is the sub-index value.

**d:** data

- When **e=0**, **s=0**: **d** is reserved for further use.
- When **e=0**, **s=1**: **d** contains the number of bytes to be uploaded. Byte 4 contains the Least Significant Bit(LSB), and byte 7 contains the Most Significant Bit(MSB).

- When **e=1**, **s=1**: **d** contains the data to be uploaded, with a length of **4-n** bytes. The encoding depends on the type of the data referenced by the index and sub-index.
- When **e=1**, **s=0**: **d** contains an unspecified number of bytes to be uploaded.

**x**: Not used, always 0

**reserved**: Reserved for further use, always 0

### Upload SDO Segment Protocol

After completing the **Initiate SDO Upload Protocol**, if the length of the data to be uploaded exceeds 4 bytes, the client will begin transmitting the data in segments and proceed to the **Upload SDO Segment Protocol** stage. The process follows these steps:

1. The client first sends an **Initiate Upload Request**, specifying the data object to be uploaded.
2. The server responds with an **Initiate Upload Response**, confirming that segment transfer will proceed and providing the relevant parameters.
3. The client starts transmitting data in segments based on the parameters provided by the server.
4. During each transfer, the client must check the **Toggle Bit** and the **Segment Completion Indicator (c)** to ensure correctness.

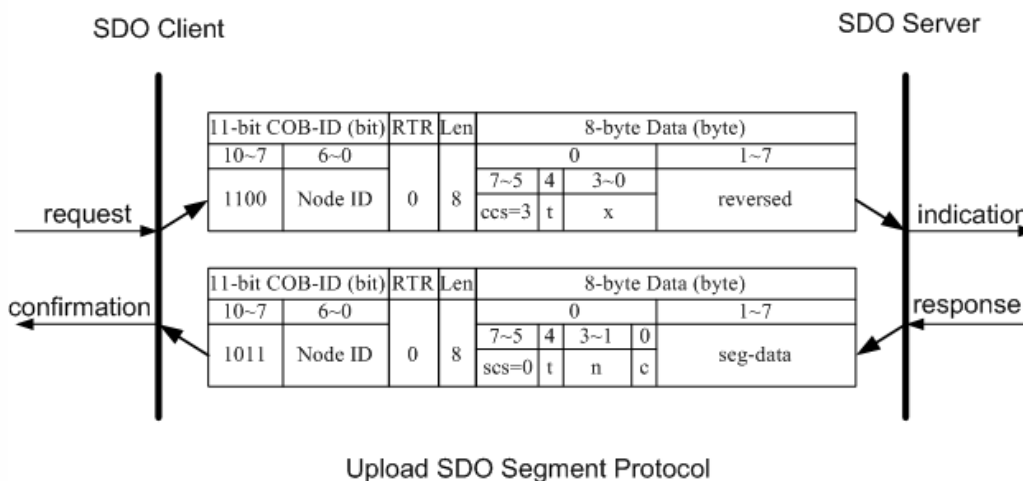

Upload SDO Segment Protocol

**ccs**: client command specifier

3: upload segment request

**scs**: server command specifier

0: upload segment response

**t**: toggle bit.

- The initial value is 0 and alternates between 0 and 1 with each new segment transfer..
- The toggle bit in the client's request and the server's response must match to ensure the segment sequence is correct.

**c** : indicates whether there are still more segments to be uploaded

0: more segments to be uploaded.

1: no more segment to be uploaded.

**seg-data**: Contains up to 7 bytes of segment data. The encoding depends on the type data referenced by index and sub-index.

**n**: Indicates the number of bytes in **seg-data** that do not contain segment data.

Bytes [8-**n**, 7] do not contain segment data.

**n** = 0 if no segment size is indicated.

**x**: Not used, always 0

**reserved**: Reserved for further use, always 0

## 9.2.1.2. Download SDO Protocol

### Initiate SDO Download Protocol

The download process is similar to the upload process, but differs slightly in the parameters used in the SDO messages. It consists of two steps.

- If the data length is less than or equal to 4 bytes:  
The download is completed using only the Initiate SDO Download Protocol.
- If the data length is greater than 4 bytes:  
The Download SDO Segment Protocol is required to transfer the data in smaller parts.

The details of the initiate SDO download protocol are as follows:

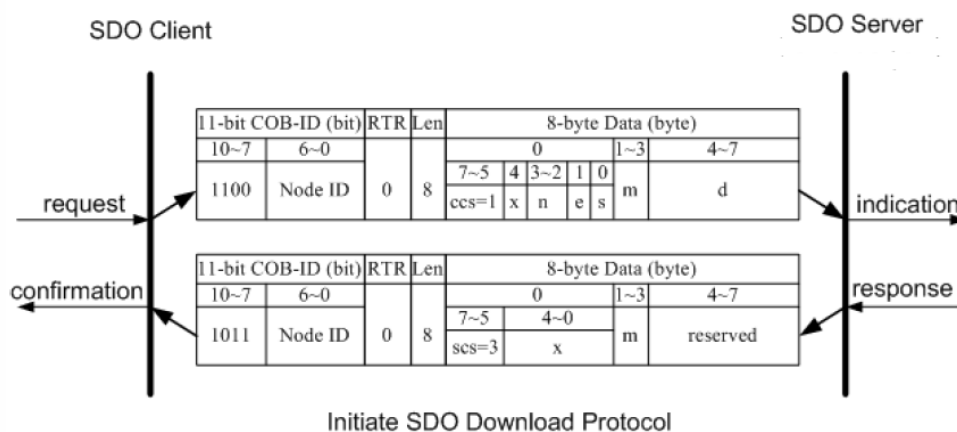

**ccs:** client command specifier

1: initiate download request

**scs:** server command specifier

3: initiate download response

**n:** Only valid if  $e = 1$  and  $s = 1$ , otherwise 0.

If this field is valid, **n** represents the number of Bytes in the **d** field that are not used to store segment data. Specifically, the Bytes in the range  $[8-n, 7]$  of the **d** field are unused and do not contain any valid data.

**e:** transfer type

0: normal transfer

1: expedited transfer

If **e=1**, it indicates that the data size is less than or equal to 4 bytes. In this case,

the transmission can be completed using only the Initiate SDO Download Protocol. If **e=0**, the Download SDO Segment Protocol is required to complete the transmission.

**s**: size indicator

0: Data set size not indicated.

1: Data set size indicated.

**m**: multiplexer

It represents the index/sub-index of the data to be transferred by the SDO.

The first two bytes are the index value and the last byte is the sub-index value.

**d**: data

- When **e=0**, **s=0**: **d** is reserved for further use.
- When **e=0**, **s=1**: **d** contains the number of bytes to be downloaded. Byte 4 contains the Least Significant Bit(LSB), and byte 7 contains the Most Significant Bit(MSB).
- When **e=1**, **s=1**: **d** contains the data to be downloaded, with a length of 4-**n** bytes. The encoding depends on the type of the data referenced by the index and sub-index.
- When **e=1**, **s=0**: **d** contains an unspecified number of bytes to be downloaded.

**x**: Not used, always 0

**reserved**: Reserved for further use, always 0

### Download SDO Segment Protocol

After completing the Initiate SDO Download Protocol, if the length of the data to be downloaded exceeds 4 bytes, the client will begin receiving the data in segments and proceed to the **Download SDO Segment Protocol** stage. The process follows these steps:

1. The client first sends a **Download Segment Request**, specifying the segment of data to be downloaded.
2. The server responds with a **Download Segment Response**, providing the segment data to be downloaded.
3. The client continues receiving data in segments based on the responses from the server.
4. During each transfer, the client must check the **Toggle Bit** and the **More Segments Indicator (c)** to ensure data integrity and proper sequence.

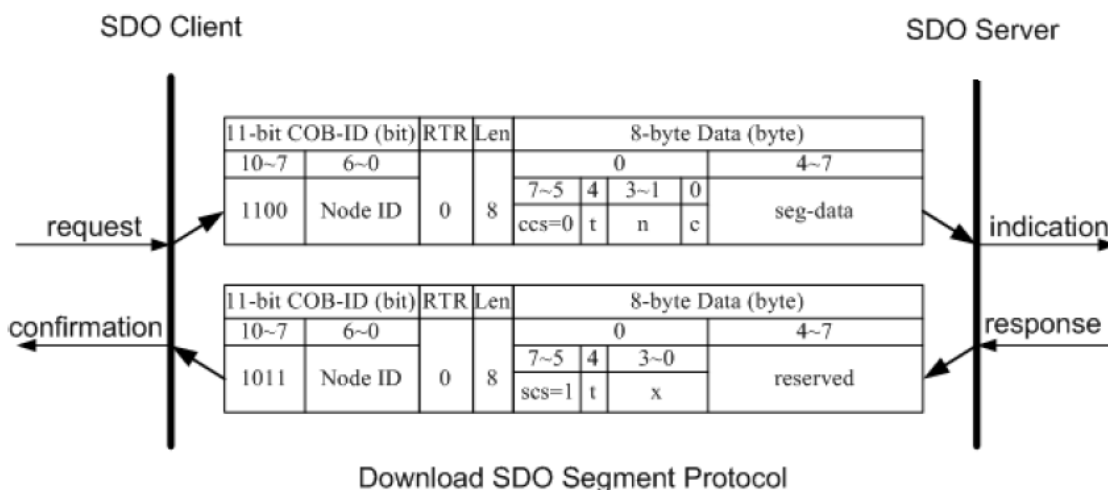

**ccs:** client command specifier

0: download segment request

**scs:** server command specifier

1: download segment response

**seg-data:** Contains up to 7 bytes of segment data to be downloaded.

The encoding of the segment depends on the type, identified by index and sub-index.

**n:** Indicates the number of bytes in **seg-data** that do not contain segment data.

Bytes [8-n, 7] do not contain segment data.

n = 0 if the segment size is not indicated.

**c:** indicates whether there are still more segments to be uploaded

0: more segments to be uploaded.

1: no more segment to be uploaded.

**t**: toggle bit

- The initial value is 0 and alternates between 0 and 1 with each new segment transfer.
- The toggle bit in the client's request and the server's response must match to ensure the segment sequence is correct.

**x**: Not used, always 0

**reserved**: Reserved for further use, always 0



Abort Code	Description
0503 0000h	Toggle bit not alternated.
0504 0000h	SDO protocol timed out.
0504 0001h	Invalid or unknown client/server command specified.
0504 0002h	Invalid block size (block mode only).
0504 0003h	Invalid sequence number (block mode only).
0504 0004h	CRC error (block mode only).
0504 0005h	Out of memory.
0601 0000h	Unsupported access to the object.
0601 0001h	Attempt to read a write-only object.
0601 0002h	Attempt to write a read-only object.
0602 0000h	Object does not exist in the object dictionary.
0604 0041h	Object cannot be mapped to the PDO.
0604 0042h	The number or size of the objects mapped exceeds the allowed PDO length.
0604 0043h	General parameter incompatibility reason.
0604 0047h	General internal incompatibility in the device.
0606 0000h	Access failed due to hardware error.
0607 0010h	Data type or service parameter length mismatch.
0607 0012h	Data type does not match, service parameter length too high.
0607 0013h	Data type does not match, service parameter length too low.
0609 0011h	Sub-index does not exist.
0609 0030h	Parameter value exceeds allowed range (only for write access).
0609 0031h	Value of parameter written too high.
0609 0032h	Value of parameter written too low.
0609 0036h	Maximum value is less than minimum value.
0800 0000h	General error.
0800 0020h	Data cannot be transferred or stored to the application.
0800 0021h	Data cannot be transferred or stored to the application due to local control.
0800 0022h	Data cannot be transferred or stored to the application due to the present device state.
0800 0023h	Object dictionary dynamic generation fails or no object dictionary is present(e.g. object dictionary is generated from file and generation fails because of a file error).

## 9.2.2. PDO Introduction

In CANopen, PDOs (Process Data Objects) enable fast, real-time data exchange between devices without requiring acknowledgment. Each PDO can transmit multiple data entries, such as measurements or status updates, and uses mapping from the object dictionary to organize data transmission efficiently.

### 9.2.2.1. PDO COB-ID Parameters

Before transmitting real-time data through the PDO, it is essential to verify the COB-ID (Communication Object Identifier) parameter in the corresponding PDO communication object. The COB-ID is a 32 bit value that defines the priority, type, and behavior of the PDO. Each bit in the CPB-ID serves a specific function, as described in the following table:

Bit Number	Value	Meaning
31(MSB)	0	PDO exists (PDO is valid)
	1	PDO does not exist (PDO is not valid)
30	0	RTR(Remote Transmission Request) allowed on this PDO
	1	No RTR allowed on this PDO
29	0	11-bit ID (CAN 2.0A)
	1	29-bit ID (CAN 2.0B)
28-11	0	If bit 29=0
	X	If bit 29=1: 28-11 bits of 29-bit COB-ID
10-0(LSB)	X	10-0 bits of COB-ID

Note: PM-3133-CPS only supports CAN 2.0A (11-bit ID).

Default PDO COB-ID parameters:

Number of PDO	Default COB-ID	
	Bit10 to Bit7 (Function Code)	Bit6 to Bit0
TxPDO1	0011	Node-ID
TxPDO2	0101	Node-ID
TxPDO3	0111	Node-ID
TxPDO4	1001	Node-ID
RxPDO1	0100	Node-ID
RxPDO2	0110	Node-ID
RxPDO3	1000	Node-ID
RxPDO4	1010	Node-ID

## Note:

1. Some COB-IDs are reserved for specific communication objects or other purposes and cannot be used by users. Except for the reserved COB-IDs, users can customize the remaining COB-IDs as PDO COB-IDs, but they must ensure that no duplicate COB-IDs are used within the same node.

The table below lists the reserved COB-IDs:

Reserved COB-ID (Hex)	Assigned Object
0	Network Management (NMT)
1	Reserved
80	Synchronization (SYNC)
81 to FF	Emergency Event (EMERGENCY)
100	Time Stamp (TIME STAMP)
101 to 180	Reserved
581 to 5FF	Default for PDO Transmission
601 to 67F	Default for PDO Reception
6E0	Reserved
701 to 77F	Network Management (NMT) Error Control
780 to 7FF	Reserved

2. PDO COB-ID parameters cannot be changed if the PDO is valid (bit 31 =0).

### 9.2.2.2. Transmission Type

The transmission type is a key parameter defined in PDO communication objects (sub-index 02). Each PDO has a specific transmission type that determines how the data is sent or received. It defines the behavior of the PDO, such as whether it is synchronous, asynchronous, or event-driven.

The table below describes the relationship between the transmission type value and the behavior of the PDO. For example, if transmission type 0 is set for the first TxPDO, the CANopen device will follow acyclic and synchronous PDO transmission rules.

Transmission Type	PDO Transmission Method				
	Cyclic	Acyclic	Synchronous	Asynchronous	RTR only
0		○	○		
1-240	○		○		
241-251	-----Reserved-----				
252			○		○
253				○	○
254				○	
255				○	

Note:

- **Transmission type 1-240:** Indicates how many SYNC objects trigger a TxPDO. RxPDO always respond to the next SYNC, regardless of the transmission type.
- **Transmission type 252 and 253:** These are used exclusively for TxPDO.
  - Type 252 updates data immediately upon receiving a SYNC signal but does not transmit the data.
  - Type 253 does not update data based on the SYNC signal and only transmits data upon receiving a Remote Transmission Request (RTR).
  - For both types, the PDO transmits data only when an RTR request is received.

- **Transmission types 254 and 255:**
  - The device can use an event timer to periodically trigger the transmission of TxPDO.
  - Additionally, if a DI or other variable is mapped to a PDO, any changes in the value of this DI will immediately trigger the transmission of the corresponding TxPDO.
  - For transmission type 255, in addition to the above triggering conditions, data transmission can also be initiated by a Remote Transmission Request (RTR).
- The PM-3133-CPS doesn't support RxPDO.

### 9.2.2.3. PDO Communication Rule

PDO-related objects are assigned indexes within the range 0x1400 to 0x1BFF. However, for the PM-3133-CPS, RxPDO communication objects are not used. The indexes for TxPDO communication objects range from 0x1800 to 0x1813, while their corresponding mapping objects are indexed from 0x1A00 to 0x1A13. Each TxPDO communication object has a corresponding PDO mapping object.

For example,

- The first TxPDO communication object is stored at **index 0x1800**, with its corresponding mapping object at **index 0x1A00**.
- Similarly, the second TxPDO communication object is stored at **0x1801**, and its mapping object at **0x1A01**, and so on.

Before accessing real-time data via PDO communication, users must ensure that all parameters for both the PDO communication objects and their mapping objects are correctly configured. Additionally, after modifying any parameters, the device must be set to the NMT Operational state to activate the new configuration.

Operational Requirements:

- PDO communication is only available when the device is in the NMT operational state.
- Users can use the NMT module control protocol (explained in section 9.2.3) to change the NMT state of the PM-3133-CPS.

Data Length Matching:

During PDO communication, the data length (L) of the PDO message must exactly match the total size (n) of the corresponding PDO mapping object.

- If  $L > n$ : Only the first n bytes of the PDO message will be processed by the PDO consumer.
- If  $L < n$ : The PDO message will be discarded, and an Emergency message(EMCY) with error code 8210h will be sent to the PDO producer.

The PDO communication set is shown as follows.

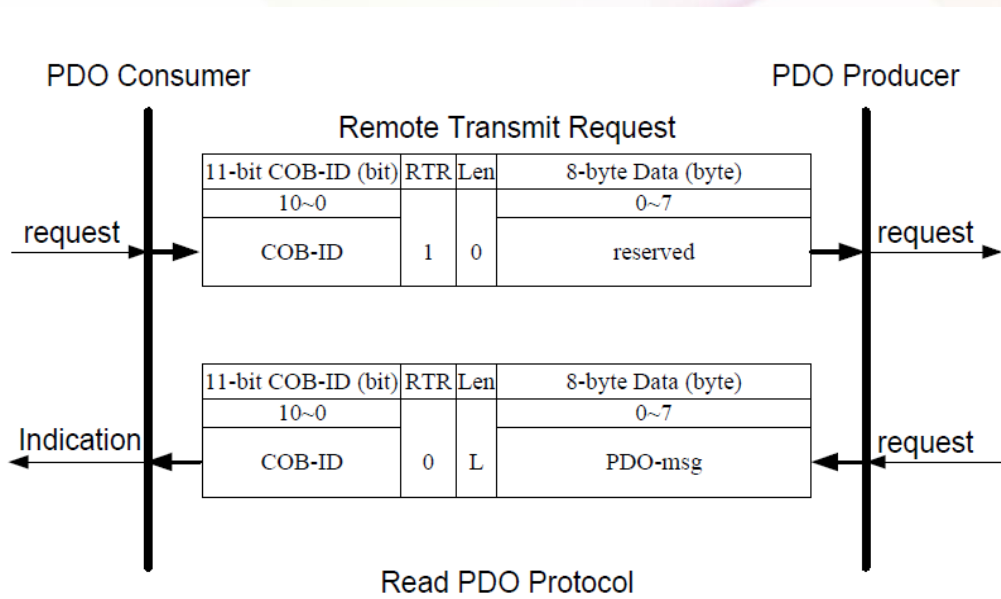

**COB-ID:** The default PDO COB-ID, or user-defined COB-ID.

**L:** The length of the PDO message (in bytes)

**PDO-msg:** Real-time data or data that can be mapped into PDO mapping objects

## 9.2.3. NMT Introduction

The NMT (Network Management) protocol is used to control the state of CANopen devices. The PM-3133-CPS supports several NMT commands that allow changing the NMT slave status. Below are the protocols used for switching between different NMT states.

### 9.2.3.1. Module Control Protocol

The following commands are used to control the NMT slave device status:

#### Start Remote Node Protocol

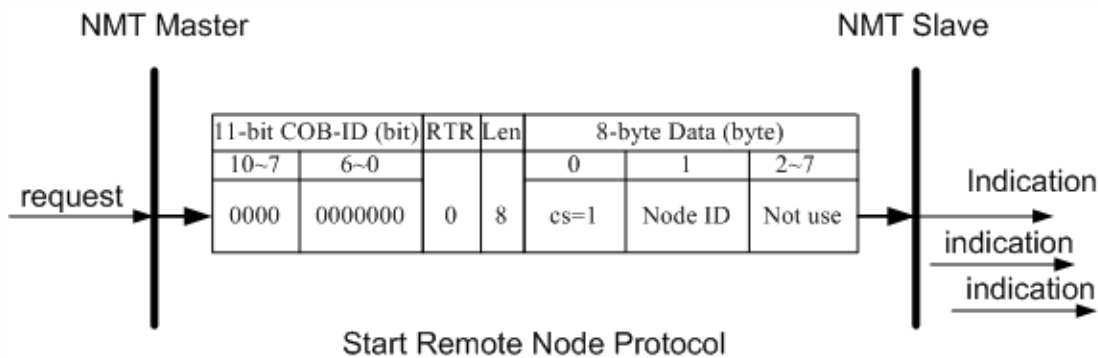

**cs:** NMT command specified

1: start

**Node ID:** the node ID of the NMT slave device

**Stop Remote Node Protocol**

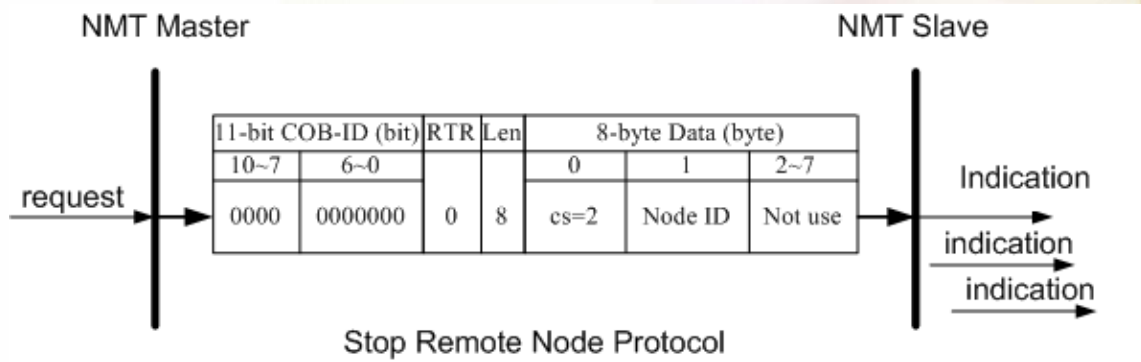

**cs:** NMT command specified

2: stop

**Node ID:** the node ID of the NMT slave device

### Enter Pre-Operational Protocol

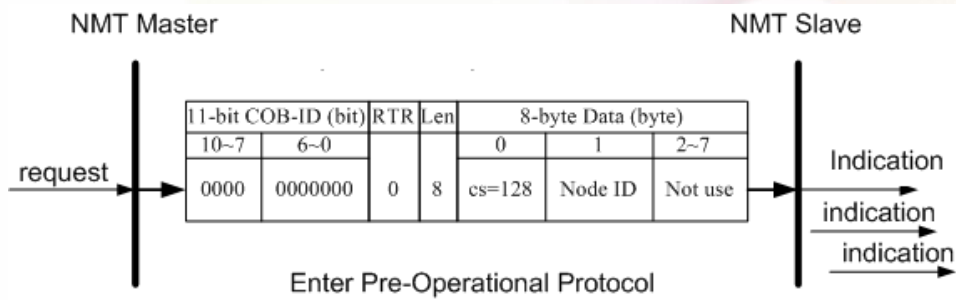

**cs:** NMT command specified

128: enter PRE-OPERATIONAL

**Node ID:** the node ID of the NMT slave device

### Reset Node Protocol

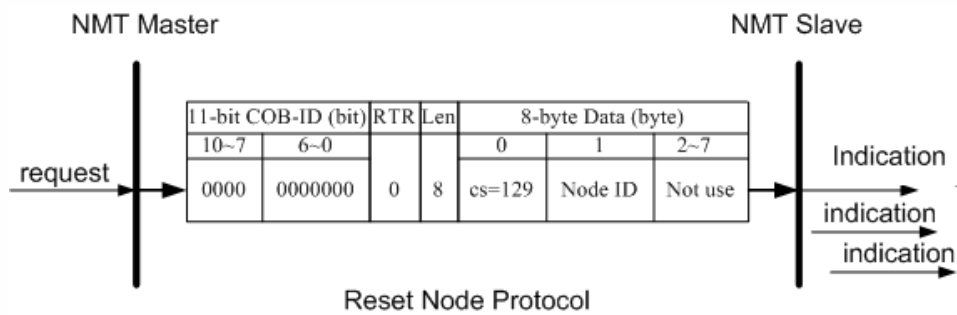

**cs :** NMT command specified

129: Reset\_Node

**Node ID:** the node ID of the NMT slave device

**Reset Communication Protocol**

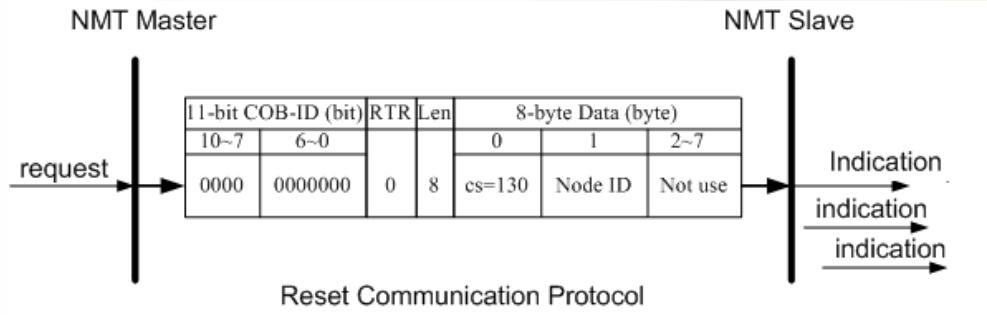

**cs:** NMT command specified

130: Reset\_Communication

**Node ID:** the node ID of the NMT slave device

### 9.2.3.2. Error Control Protocol

The **Error Control Protocol** ensures that the CANopen device is active and responsive. It uses two key objects:

- **0x100C: Guard Time** (the interval between status checks)
- **0x100D: Life Time Factor** (a multiplier that extends the waiting period)

The **Node Life Time** defines the maximum amount of time the system will wait for a response from the PM-3133-CPS before considering it unresponsive. It is calculated by multiplying the **Guard Time** by the **Life Time Factor**.

Formula:

Node Life Time = Guard Time × Life Time Factor

When the **PM-3133-CPS** receives the first **RTR (Remote Transmission Request)** — used by the master to verify if the device is active—the **Node Guarding Timer** starts. This timer tracks the time since the last response from the node:

- **If the node responds** within the Node Life Time, the timer resets.
- **If the node does not respond** before the timer expires, the system raises an **error**, indicating the device may be offline or unresponsive.

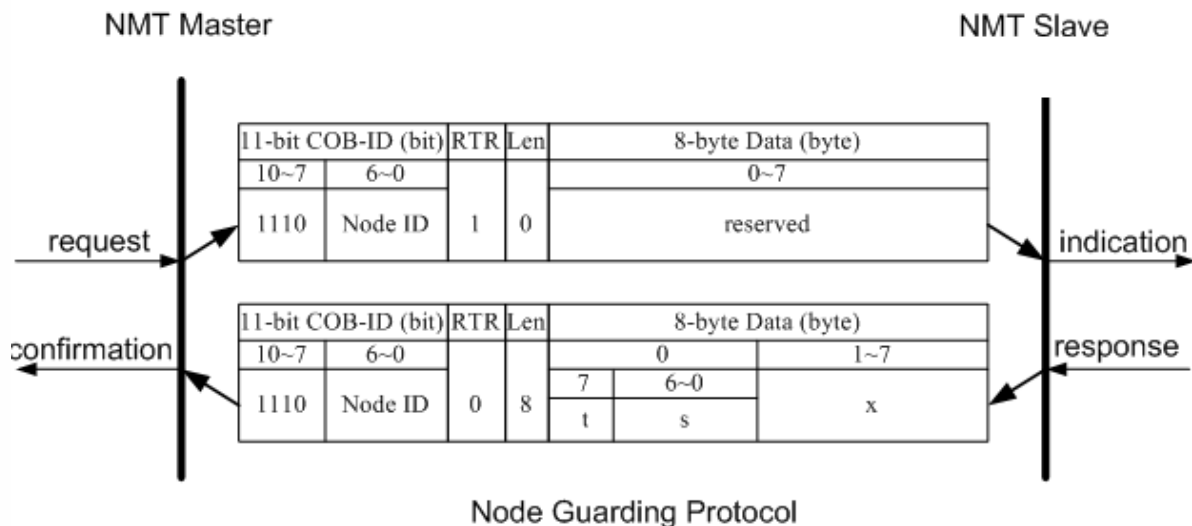

**t:** toggle bit

- The toggle bit alternates between 0 and 1 with each consecutive response from the NMT slave.
- When the Node Guarding protocol becomes active, the toggle bit in the first response will be set to 0.

**s:** the state of the NMT Slave

4: STOPPED

5: OPERATIONAL

127: PRE\_OPERATIONAL

## 9.2.4. Special Functions for PM-3133-CPS

The PM-3133-CPS module offers a range of specialized functions tailored for power monitoring applications. These include data storage entries in the Manufacturer Specific Profile Area, which provide access to key power meter data. This data is mapped to PDOs (Process Data Objects) for efficient communication within CANopen networks. The following sections outline the structure and mapping details of these entries.

### 9.2.4.1. Power Meter Data Table

The **PM-3133-CPS** defines several entries in the Manufacturer Specific Profile Area that are used to store power meter data. These entries, indexed from **0x3200 to 0x3208**, are mapped to **PDOs** (Process Data Objects) as shown in the table below. Each PDO message consists of **8 bytes** divided between **D0 to D7**, representing fields for CANopen messages from **Data0 to Data7**.

No.(PDO)	COB-ID	Data Length	D0 to D3	D4 to D7
1	0x180+Node-ID	8	kW(Kw_a)	kWh_a
2	0x280+Node-ID	8	kW(Kw_b)	kWh_b
3	0x380+Node-ID	8	kW(Kw_c)	kWh_c
4	0x480+Node-ID	8	kW(Kw_tot)	kWh_tot
5	---	8	Volt(V_a)	Amp(I_a)
6	---	8	Volt(V_b)	Amp(I_b)
7	---	8	Volt(V_c)	Amp(I_c)
8	---	8	Volt(V_avg)	Amp(I_avg)
9	---	8	kvar(kvar_a)	kVA(Kva_a)
10	---	8	kvar(kvar_b)	kVA(Kva_b)
11	---	8	kvar(kvar_c)	kVA(Kva_c)
12	---	8	kvar(kvar_tot)	kVA(Kva_tot)
13	---	8	PF_a	kVAh_a
14	---	8	PF_b	kVAh_d
15	---	8	PF_c	kVAh_c
16	---	8	PF_tot	kVAh_tot

17	---	8	kvarh_a	Freq_a
18	---	8	kvarh_b	Freq_b
19	---	8	kvarh_c	Freq_c
20	---	8	kvarh_tot	Freq_avg

## 9.3. Object Dictionary of PM-3133-CPS

The **Object Dictionary** in PM-3133-CPS contains all the communication-related parameters and manufacturer-specific entries. The dictionary follows the CANopen protocol, enabling flexible configuration and communication of the power meter. It is divided into several key areas:

- **Communication Profile Area:** This section defines general communication objects.
- **Manufacturer-Specific Profile Area:** This section includes entries for specific features or measurement data unique to PM-3133-CPS.
- **Storage and Restoration of Objects:** This section manages parameter storage and restoration.

### 9.3.1. Communication Profile Area

The **Communication Profile Area** lists the communication parameters essential for CANopen operations. For easier reference, this section is divided into three tables:

1. **General Communication Entries:** Lists device-related identifiers and communication control parameters.
2. **TxPDO Communication Entries:** Contains information about the transmission PDOs.
3. **TxPDO Mapping Communication Entries:** Lists mapping rules for the PDOs.

The column headers are explained as follows:

- **Idx:** The index within the object dictionary.
- **Sidx:** Sub-index for finer control of entries.
- **Attr:** Attributes, such as **RO** (Read-Only) or **RW** (Read-Write).
- **Default:** Default value assigned to the parameter. If the default value is shown as "--", it means it is either undefined or may be assigned dynamically by the **PM-3133-CPS firmware**.

Additionally, any number with the suffix "**h**" is presented in **hexadecimal format**.

**General Communication Entries**

Idx	Sidx	Description	Type	Attr	Default
1000h	0h	device type	UNSIGNED 32	RO	---
1001h	0h	error register	UNSIGNED 8	RO	---
1003h	0h	largest sub-index supported for "predefine error field"	UNSIGNED 8	RO	0h
	1h	actual error (newest)	UNSIGNED 32	RO	---
	...	...	...	...	---
	5h	actual error (oldest)	UNSIGNED 32	RO	---
1005h	0h	COB-ID of Sync message	UNSIGNED 32	RW	80h
1008h	0h	manufacturer device name	VISIBLE_STRING	RO	
1009h	0h	manufacturer hardware version	VISIBLE_STRING	RO	---
100Ah	0h	manufacturer software version	VISIBLE_STRING	RO	---
100Ch	0h	guard time	UNSIGNED 16	RW	0
100Dh	0h	life time factor	UNSIGNED 8	RW	0
1010h	0h	largest sub-index supported for "store parameters"	UNSIGNED 8	RO	1
	1h	save all parameters	UNSIGNED 32	RW	0
1011h	0h	largest sub-index supported for "restore default parameters"	UNSIGNED 8	RO	1
	1h	restore all default parameters	UNSIGNED 32	RW	0
1014h	0h	COB-ID of EMCY	UNSIGNED 32	RW	80h+Node-ID
1015h	0h	inhibit time of EMCY	UNSIGNED 16	RW	0
1017h	0h	heartbeat time	UNSIGNED 16	RW	0
1018h	0h	largest sub-index supported for "identity object"	UNSIGNED 8	RO	1
	1h	vender ID	UNSIGNED 32	RO	---
1F52	0h	largest sub-index supported for "firmware update"	UNSIGNED 8	RO	1
	1h	start to update firmware	UNSIGNED 8	WO	---

**SDO Communication Entries**

Idx	Sidx	Description	Type	Attr	Default
1200h	0h	largest sub-index supported for "server SDO parameter"	UNSIGNED 8	RO	2
	1h	COB-ID form client to server	UNSIGNED 32	RO	600h+Node-ID

		(RxSDO)			
	2h	COB-ID form server to client (TxSDO)	UNSIGNED 32	RO	580h+Node-ID

**TxPDO Communication Entries**

Idx	Sidx	Description	Type	Attr	Default
1800h	0	largest sub-index supported for "receive PDO parameter"	UNSIGNED 8	RO	5
	1	COB-ID used by PDO (Tx)	UNSIGNED 32	RW	180h+Node-ID
	2	transmission type	UNSIGNED 8	RW	FFh
	3	inhibit time	UNSIGNED 16	RW	0
	4	Reversed	...	...	...
	5	event timer	UNSIGNED 16	RW	0
1801h	0	largest sub-index supported for "receive PDO parameter"	UNSIGNED 8	RO	5
	1	COB-ID used by PDO (Tx)	UNSIGNED 32	RW	280h+Node-ID
	2	transmission type	UNSIGNED 8	RW	FFh
	3	inhibit time	UNSIGNED 16	RW	0
	4	Reversed	...	...	...
	5	event timer	UNSIGNED 16	RW	0
1802h	0	largest sub-index supported for "receive PDO parameter"	UNSIGNED 8	RO	5
	1	COB-ID used by PDO (Tx)	UNSIGNED 32	RW	380h+Node-ID
	2	transmission type	UNSIGNED 8	RW	FFh
	3	inhibit time	UNSIGNED 16	RW	0
	4	Reversed	...	...	...
	5	event timer	UNSIGNED 16	RW	0
1803h	0	largest sub-index supported for "receive PDO parameter"	UNSIGNED 8	RO	5
	1	COB-ID used by PDO (Tx)	UNSIGNED 32	RW	480h+Node-ID
	2	transmission type	UNSIGNED 8	RW	FFh
	3	inhibit time	UNSIGNED 16	RW	0
	4	Reversed	...	...	...
	5	event timer	UNSIGNED 16	RW	0
1804h	0	largest sub-index supported for "receive PDO parameter"	UNSIGNED 8	RO	5

	1	COB-ID used by PDO (Tx)	UNSIGNED 32	RW	80000000h
	2	transmission type	UNSIGNED 8	RW	FFh
	3	inhibit time	UNSIGNED 16	RW	0
	4	Reversed	...	...	...
	5	event timer	UNSIGNED 16	RW	0
...	...	...	...	...	...
1813h	0	largest sub-index supported for "receive PDO parameter"	UNSIGNED 8	RO	5
	1	COB-ID used by PDO (Tx)	UNSIGNED 32	RW	80000000h
	2	transmission type	UNSIGNED 8	RW	FFh
	3	inhibit time	UNSIGNED 16	RW	0
	4	Reversed	...	...	...
	5	event timer	UNSIGNED 16	RW	0

**TxPDO Mapping Communication Entries**

Idx	Sidx	Description	Type	Attr	Default
1A00h	0	largest sub-index supported for "transmit PDO mapping"	UNSIGNED 8	RO	2
	1	read Kw_a data	INTEGER 32	RO	3200 0120h
	2	read kWh_a data	INTEGER 32	RO	3201 0120h
1A01h	0	largest sub-index supported for "transmit PDO mapping"	UNSIGNED 8	RO	2
	1	read Kw_b data	INTEGER 32	RO	3200 0220h
	2	read kWh_b data	INTEGER 32	RO	3201 0220h
1A02h	0	largest sub-index supported for "transmit PDO mapping"	UNSIGNED 8	RO	2
	1	read Kw_c data	INTEGER 32	RO	3200 0320h
	2	read kWh_c data	INTEGER 32	RO	3201 0320h
1A03h	0	largest sub-index supported for "transmit PDO mapping"	UNSIGNED 8	RO	2
	1	read Kw_tot data	INTEGER 32	RO	3200 0420h
	2	read kWh_tot data	INTEGER 32	RO	3201 0420h
1A04h	0	largest sub-index supported for "transmit PDO mapping"	UNSIGNED 8	RO	2
	1	read V_a data	INTEGER 32	RO	3202 0120h
	2	read I_a data	INTEGER 32	RO	3203 0120h

1A05h	0	largest sub-index supported for “transmit PDO mapping”	UNSIGNED 8	RO	2
	1	read V_b data	INTEGER 32	RO	3202 0220h
	2	read I_b data	INTEGER 32	RO	3203 0220h
1A06h	0	largest sub-index supported for “transmit PDO mapping”	UNSIGNED 8	RO	2
	1	read V_c data	INTEGER 32	RO	3202 0320h
	2	read I_c data	INTEGER 32	RO	3203 0320h
1A07h	0	largest sub-index supported for “transmit PDO mapping”	UNSIGNED 8	RO	2
	1	read V_avg data	INTEGER 32	RO	3202 0420h
	2	read I_avg data	INTEGER 32	RO	3203 0420h
1A08h	0	largest sub-index supported for “transmit PDO mapping”	UNSIGNED 8	RO	2
	1	read kvar(kvar_a) data	INTEGER 32	RO	3204 0120h
	2	read kVA(Kva_a) data	INTEGER 32	RO	3205 0120h
1A09h	0	largest sub-index supported for “transmit PDO mapping”	UNSIGNED 8	RO	2
	1	read kvar(kvar_b) data	INTEGER 32	RO	3204 0220h
	2	read kVA(Kva_b) data	INTEGER 32	RO	3205 0220h
1A0Ah	0	largest sub-index supported for “transmit PDO mapping”	UNSIGNED 8	RO	2
	1	read kvar(kvar_c) data	INTEGER 32	RO	3204 0320h
	2	read kVA(Kva_c) data	INTEGER 32	RO	3205 0320h
1A0Bh	0	largest sub-index supported for “transmit PDO mapping”	UNSIGNED 8	RO	2
	1	read kvar_tot data	INTEGER 32	RO	3204 0420h
	2	read Kva_tot data	INTEGER 32	RO	3205 0420h
1A0Ch	0	largest sub-index supported for “transmit PDO mapping”	UNSIGNED 8	RO	2
	1	read PF_a data	INTEGER 32	RO	3206 0120h
	2	read kVAh_a data	INTEGER 32	RO	3207 0120h
1A0Dh	0	inhibit time	UNSIGNED 8	RO	2
	1	read PF_b data	INTEGER 32	RO	3206 0220h
	2	read kVAh_b data	INTEGER 32	RO	3207 0220h
1A0Eh	0	largest sub-index supported for	UNSIGNED 8	RO	2

		“transmit PDO mapping”			
	1	read PF_c data	INTEGER 32	RO	3206 0320h
	2	read kVAh_c data	INTEGER 32	RO	3207 0320h
1A0Fh	0	largest sub-index supported for “transmit PDO mapping”	UNSIGNED 8	RO	2
	1	read PF_tot data	INTEGER 32	RO	3206 0420h
	2	read kVAh_tot data	INTEGER 32	RO	3207 0420h
1A10h	0	largest sub-index supported for “transmit PDO mapping”	UNSIGNED 8	RO	2
	1	read kvarh_a data	INTEGER 32	RO	3208 0120h
	2	read Freq_a data	INTEGER 32	RO	3209 0120h
1A11h	0	largest sub-index supported for “transmit PDO mapping”	UNSIGNED 8	RO	2
	1	read kvarh_b data	INTEGER 32	RO	3208 0220h
	2	read Freq_b data	INTEGER 32	RO	3209 0220h
1A12h	0	largest sub-index supported for “transmit PDO mapping”	UNSIGNED 8	RO	2
	1	read kvarh_c data	INTEGER 32	RO	3208 0320h
	2	read Freq_c data	INTEGER 32	RO	3209 0320h
1A13h	0	largest sub-index supported for “transmit PDO mapping”	UNSIGNED 8	RO	2
	1	read kvarh_tot data	INTEGER 32	RO	3208 0420h
	2	read Freq_avg data	INTEGER 32	RO	3209 0420h

### 9.3.2. Manufacturer Specific Profile Area

The following table lists the special feature items for the **PM-3133-CPS**. Entries indexed from **0x3200 to 0x3209** record the power meter measurement parameters. These values are automatically updated each time the PM-3133-CPS boots.

- **0x320A:** Contains **meter parameter information**.
- **0x320B:** Stores three key meter parameters: **PT Ratio**, **CT Ratio**, and **Meter Ratio**.
  - ✓ **PT Ratio:** Potential transformer ratio. The default value is **100**, with a unit of **0.1**.
  - ✓ **CT Ratio:** Current transformer ratio. The default value is **1**, with a unit of **1**.

Idx	Sidx	Description	Type	Attr	Default
3200h	0	largest sub-index supported for "kW"	UNSIGNED 8	RO	4
	1	kW(Kw_a)	REAL 32	RO	0
	2	kW(Kw_b)	REAL 32	RO	0
	3	kW(Kw_c)	REAL 32	RO	0
	4	kW(Kw_tot)	REAL 32	RO	0
3201h	0	largest sub-index supported for "kWh"	UNSIGNED 8	RO	4
	1	kWh_a	REAL 32	RO	0
	2	kWh_b	REAL 32	RO	0
	3	kWh_c	REAL 32	RO	0
	4	kWh_tot	REAL 32	RO	0
3202h	0	largest sub-index supported for "Volt"	UNSIGNED 8	RO	4
	1	Volt(V_a)	REAL 32	RO	0
	2	Volt(V_b)	REAL 32	RO	0
	3	Volt(V_c)	REAL 32	RO	0
	4	Volt(V_avg)	REAL 32	RO	0
3203h	0	largest sub-index supported for "Amp"	UNSIGNED 8	RO	4
	1	Amp(I_a)	REAL 32	RO	0
	2	Amp(I_b)	REAL 32	RO	0
	3	Amp(I_c)	REAL 32	RO	0
	4	Amp(I_avg)	REAL 32	RO	0

3204h	0	largest sub-index supported for "kvar"	UNSIGNED 8	RO	4
	1	kvar(kvar_a)	REAL 32	RO	0
	2	kvar(kvar_b)	REAL 32	RO	0
	3	kvar(kvar_c)	REAL 32	RO	0
	4	kvar(kvar_tot)	REAL 32	RO	0
3205h	0	largest sub-index supported for "kVA"	UNSIGNED 8	RO	4
	1	kVA(Kva_a)	REAL 32	RO	0
	2	kVA(Kva_b)	REAL 32	RO	0
	3	kVA(Kva_c)	REAL 32	RO	0
	4	kVA(Kva_tot)	REAL 32	RO	0
3206h	0	largest sub-index supported for "PF"	UNSIGNED 8	RO	4
	1	PF_a	REAL 32	RO	0
	2	PF_b	REAL 32	RO	0
	3	PF_c	REAL 32	RO	0
	4	PF_tot	REAL 32	RO	0
3207h	0	largest sub-index supported for "kVAh"	UNSIGNED 8	RO	4
	1	kVAh_a	REAL 32	RO	0
	2	kVAh_b	REAL 32	RO	0
	3	kVAh_c	REAL 32	RO	0
	4	kVAh_tot	REAL 32	RO	0
3208h	0	largest sub-index supported for "kvarh"	UNSIGNED 8	RO	4
	1	kvarh_a	REAL 32	RO	0
	2	kvarh_b	REAL 32	RO	0
	3	kvarh_c	REAL 32	RO	0
	4	kvarh_tot	REAL 32	RO	0
3209h	0	largest sub-index supported for "Frequency"	UNSIGNED 8	RO	4
	1	Freq_a	REAL 32	RO	0
	2	Freq_b	REAL 32	RO	0
	3	Freq_c	REAL 32	RO	0
	4	Freq_avg	REAL 32	RO	0

320Ah	0	Number of entries for "Total Harmonic Distortion"	UNSIGNED 8	RO	2
	1	VTHD	REAL 32	RO	0
	2	ITHD	REAL 32	RO	0
320Bh	0	Number of entries for "System Parameter Setting"	UNSIGNED 8	RO	6
	1	PT Ratio	UNSIGNED 16	RW	100
	2	CT Ratio	UNSIGNED 16	RW	1
	3	Wiring Mode	UNSIGNED 8	RW	Default:5 1: 1P2W 2: 1P3W 3: 3P3W2CT 4: 3P3W3CT 5: 3P4W3CT
	4	Energy Absolute Accumulated Mode	UNSIGNED 8	RW	0
	5	Harmonic Phase Select	UNSIGNED 8	RW	0
	6	Display Voltage	UNSIGNED 8	RW	0
320Ch	0	Number of entries for "System Parameter Setting"	UNSIGNED 8	RO	3
	1	Set Energy to Zero	UNSIGNED 8	WO	55h
	2	Reset to Factory Settings	UNSIGNED 8	WO	55h
	3	Default Frequency	UNSIGNED 8	RW	55h
320Dh	0	Number of entries for "System Information"	UNSIGNED 8	RO	3
	1	Wiring Type	UNSIGNED 16	RO	0Dh
	2	Phase Sequence	UNSIGNED 16	RO	--
	3	Model Type	UNSIGNED 16	RO	02h
3230h	0	Number of entries for "Bi-direction Energy"	UNSIGNED 8	RO	4
	1	Bi_Positive_kWh	REAL 32	RO	--
	2	Bi_Negative_kWh	REAL 32	RO	--
	3	Bi_Net_kWh	REAL 32	RO	--
	4	Bi_Total_kWh	REAL 32	RO	

### 9.3.3. Store and Restore Object

This section describes how users can store application settings and restore the default settings on the PM-3133-CPS.

- To **store application settings**, write the value 65766173h to the object at **index 1010h, sub-index 1**.
- To **restore the default factory settings**, write the value 64616F6Ch to the object at **index 1011h, sub-index 1** and reboot the module.

The following table outlines the specific objects that will be stored or restored when these actions are performed.

Table: Objects Stored or Restored During Operations

Index	Sub-index	Description
100Ch	0	Guard time
100Dh	0	Life time factor
1017h	0	Heartbeat time
1800h	1~5	TxPDO1 parameter
.....	.....	.....
1813h	1~5	TxPDO1 parameter
2010h	1	DO power on value

**Note:**

For **power meter system parameters settings** (such as object **320Bh**), users need to write the value 55h to index 320Ch, sub-index 02h to load the default factory settings.

### 9.3.4. Firmware Update Object

This section describes how to update the firmware of the PM-3133-CPS via CAN Bus.

**Note:** This function is supported only on firmware version “**3.60-20250618**” and later. (Check the version via **Object 0x100A**.)

Before starting the firmware update process, users must prepare the following:

- The **FW\_Update\_CAN\_Tool** firmware update utility.
- A compatible **ICP DAS CAN module**. (see tool interface for supported modules)

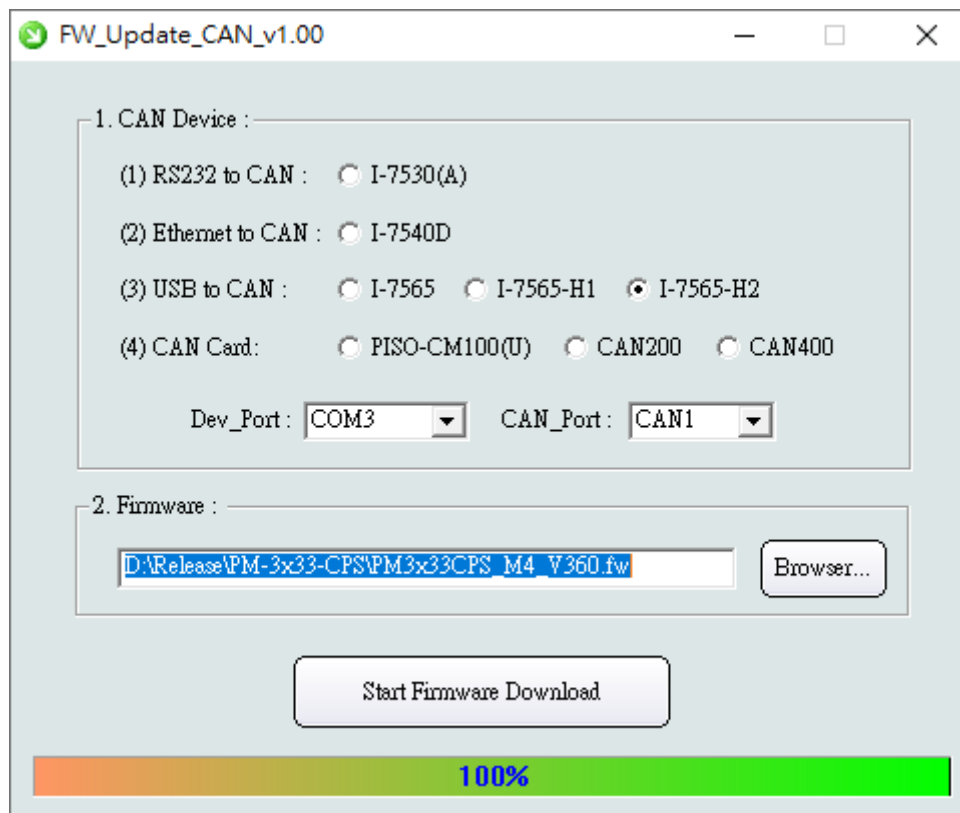

The firmware update procedure is as follows:

- **Enter Firmware Update Mode:** Write **1** to **Object 1F52h, Sub-index 1**. If successful, the **RUN LED** will turn off and the device will enter update mode.
- **Start Firmware Update:** Open the update tool, select the CAN device and port, choose the firmware file, and then click “**Start Firmware Download**”. The process takes about **1–2 minutes**, with the **RFU LED** blinking rapidly. The device will reboot automatically after completion.
- **Cancel Update Mode:** If you don't proceed with the update, simply power cycle the device to exit update mode.

## 10. Appendix: Questions & Answers

**Q1. Can we use other 5A CTs (e.g., 300/5) directly with the input current terminals of the PM-3133 series?**

**Answer:** No, you cannot directly use other 5A CTs, such as 300/5 or 100/5, with the PM-3133 series because the input current terminals are designed for milliamp (mA) inputs only. Directly connecting 5A CTs could cause fatal damage. Use the included split-type clip-on CT provided with the PM-3133 series to connect with the secondary 5A output of other CTs for testing.

**Q2. Can I replace the failed split-type clip-on CT by detaching it? Is there anything I should pay attention to?**

**Answer:** Yes, you can replace a failed CT, but always ensure that the CT is disconnected from the power cable of the monitored equipment before detaching the CT wires from the meter terminals. Failure to do so may result in severe injury.

**Q3. How should I handle a split-type clip-on CT if the turning point or internal Ferrite-core breaks?**

**Answer:** A damaged CT will yield inaccurate measurements and should no longer be used. Replace it with a new CT.

**Q4. Can I mix and match the CTs and meters from multiple PM-3133 series units?**

**Answer:** No, do not mix CTs and meters between different units. Each smart meter and its attached CTs are calibrated as a set. Mixing them may result in inaccurate measurements.

**Q5. What should I do if the power consumption readings (kW) are negative?****Answer:**

- (1) Verify the connections on the current input terminals to ensure they follow the sequence **CT1-K, CT1-L, CT2-K, CT2-L, CT3-K, and CT3-L**, in the correct white-black pattern.
- (2) Check the current flow direction (K → L) to confirm it matches the arrow direction on the clip-on CT.
- (3) An incorrect wiring sequence for voltage or current inputs may result in phase angle calculation errors. This can cause the power meter to misinterpret the direction of power flow, leading to negative KW readings or abnormally low Power Factor (PF) values.

**Q6. Why can't the PC connect to the meter over RS-485 ?****Answer:**

- (1) **Confirm the Modbus address:** Ensure the Modbus address is set correctly. The default value is 1.
- (2) **Check the baud rate:** The default baud rate is 19200.
- (3) **Verify the stop bit:** Ensure the stop bit is configured to 1.
- (4) **Check the RS-485 wiring:** Verify that the D+/D- connections are correctly wired.
- (5) **Ensure the RS-485 master provides bias:** The RS-485 master must provide bias for the PM-3133 series. If not, use a tM-SG4 or SG-785 module to supply the required bias. All ICP DAS controllers and converters are equipped to provide this bias.

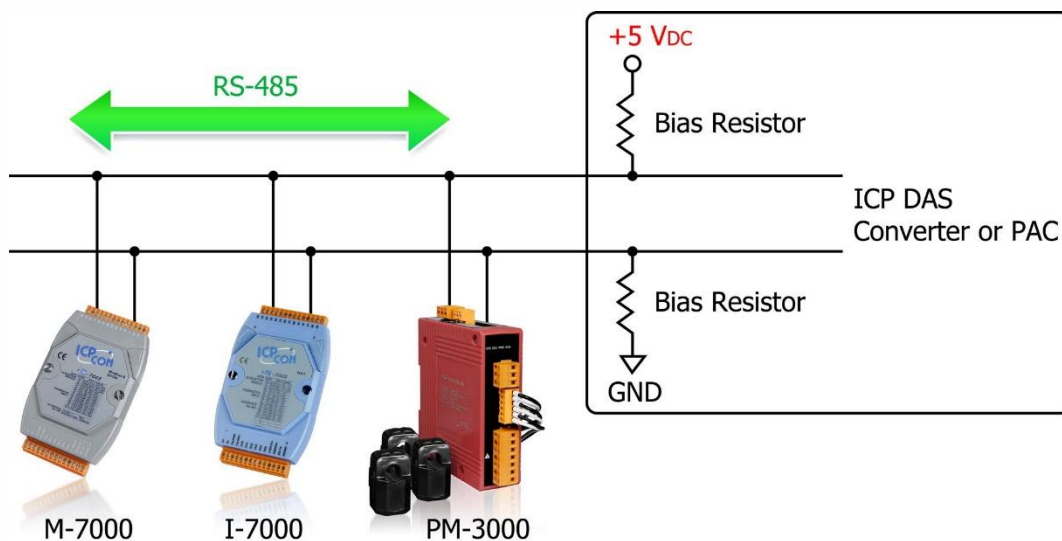

**Q7. What power cable diameter (in mm) should be used with the various CTs?**

**Answer:**

- **≤Φ 10 mm:** Use a 60A CT.
- **Φ10 to Φ16 mm:** Use a 100A CT.
- **Φ16 to Φ24 mm:** Use a 200A CT.
- **Φ36 mm:** Use a 300A or 400A CT.

**Q8. What if the wire length for the split-type clip-on CT is insufficient?**

**Answer:**

- PM-3133-xxx CTs: Standard length is 1.8 m
- PM-3133-xxxP CTs: Standard length is 4 m
- CT cable length can be extended to 8 meters (excluding Rogowski coil type CT), with no loss in accuracy. It is recommended to use twisted pair wires with AWG 18–14 (cross-sectional area 0.75–2.0 mm<sup>2</sup>) to reduce interference.
- For custom lengths, contact ICP DAS.

**Q9. How can I measure currents exceeding 400A?**

**Answer:** The maximum current range for the CTs used with the PM-3133 is **400A**. If the target current exceeds 400A, consider the following solution:

For example, to measure a current of up to **800A**, use a **primary CT** with the appropriate output and configure the **CT ratio** in the PM-3133 to scale the readings correctly.

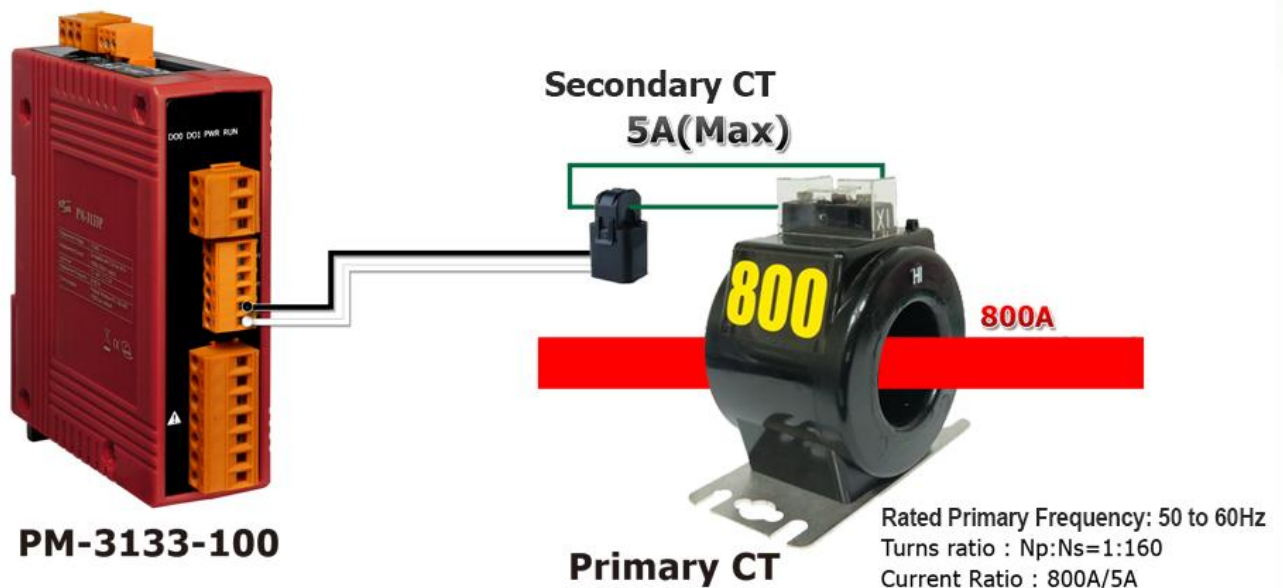

**Note:**

- A. The accuracy of the primary CT will affect the measurement accuracy.
- B. Even if the primary CT has a maximum output of 5A, do not connect it directly to the PM-3133 or PM-3133P.

**Q10. What is the difference between line-to-line voltage and line-to-ground voltage?**

**Answer:**

In a three-phase wye-connected system:

**Line-to-line voltage** is the voltage between terminals A-B, B-C, and A-C.

**Line-to-ground voltage** is the voltage between terminals A-N, B-N, and C-N.

**Calculation:**

Line-to-ground voltage = Line-to-line voltage  $\div \sqrt{3}$  (approximately 1.73)

**Example:**

In a 380V wye system, the line-to-line voltage is 380V, so the line-to-ground voltage is  $380 \div 1.73 = 220V$ .

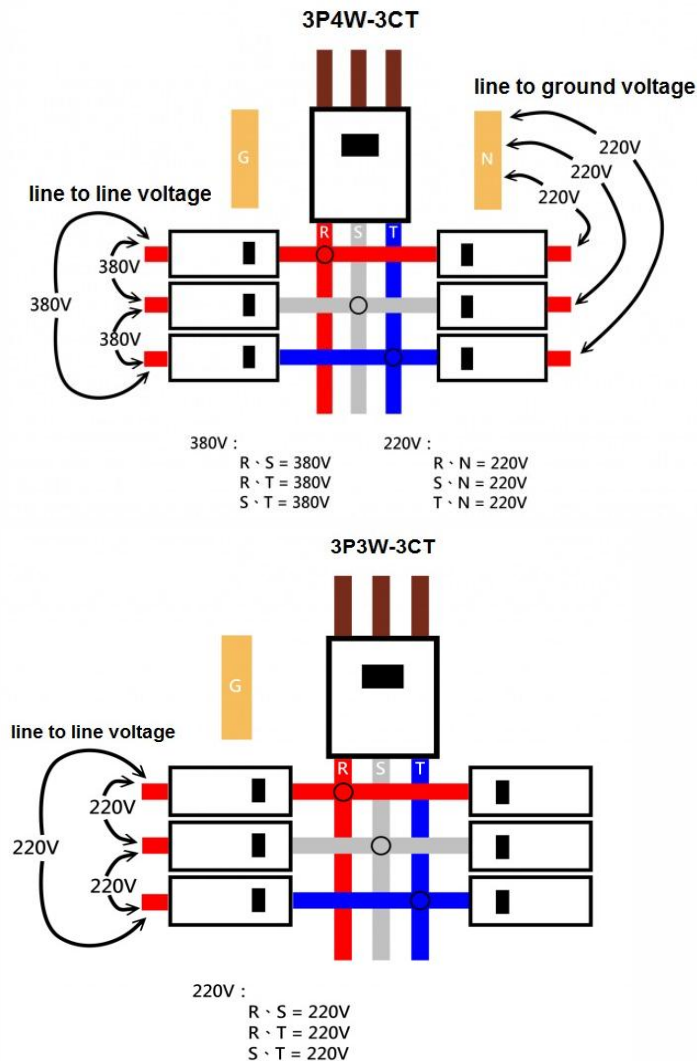

**Q11. How do I set the [Display Voltage] register to correctly display line-to-ground voltage or line-to-line voltage?****Answer:**

The voltage [V\_x] register in the Modbus register table can be configured to display either line-to-ground or line-to-line voltage by adjusting the [Display Voltage] register.

Depending on the wiring type, different [Display Voltage] values are required. If the voltage reading is not as expected, refer to the table below and ensure the correct setting:

Wiring Type	Line-to-Ground Voltage	Line-to-Line Voltage
3P3W-2CT	[Display Voltage] = 1 (Show as Vln)	[Display Voltage] = 0 (Default)
3P3W-3CT	[Display Voltage] = 0 (Default)	[Display Voltage] = 2 (Show as Vll)
3P4W-3CT	[Display Voltage] = 0 (Default)	[Display Voltage] = 2 (Show as Vll)

**Q12. What is the harmonic (THD) analysis capability?****Answer:**

The number of harmonics **N** that can be analyzed within the 2.8 kHz pass band is determined by the formula:

$$N = [2800/f], N \leq 63$$

Here, **N** must be a whole number. The maximum number of harmonics that the Energy Metering IC can analyze is 63.

**Q13. How do I measure Voltage above 500V?****Answer:**

For service voltage above 500 Vac, voltage transformers (PTs) are used to step down the voltage to a range that compatible with the PM-3133 meter.

**Selecting a Transformer:**

- **Input Voltage:**

Ensure the transformer is designed to operate at your facility's supply voltage (e.g., **PRI. Voltage 720V; SEC. Voltage 120V**). Check the connection diagram for compatibility with the wiring configuration (e.g., three-phase Y or delta) and confirm the correct phase sequence.

- **PT Ratio:**

The addition of potential transformers (PTs) reduces the measured voltage by the PT ratio (e.g., 6:1). In this case, a 720 Vac input would be transformed to 120 Vac. Since the meter receives 120 Vac, the readings must be scaled by the PT ratio (in this example, multiplied by 6) to reflect the correct voltage.

- **Frequency:**

Ensure the transformer is rated for the appropriate frequency. Most systems in the United States operate at **60 Hz**, while some other regions may require **50 Hz**-rated transformers.

- **Accuracy:**

The accuracy of the Transformer (PT) (e.g., **1%** or **3%**) will affect the precision of the measurement. Choose a transformer with an accuracy rating that meets your requirements.

- **Rated Output (VA):**

Ensure the transformer has an adequate power rating to handle the load. For example, a **150 VA** transformer (50VA per phase) would be suitable for many applications.

**Q14. Can the Power Meter be connected to a remote display via RS-485?**

**Answer:**

**A:** The Power Meter can be connected to **VPD-13x** or **VPD-14x** series displays via RS-485 for remote monitoring.

VPD-14x/VPD-13x

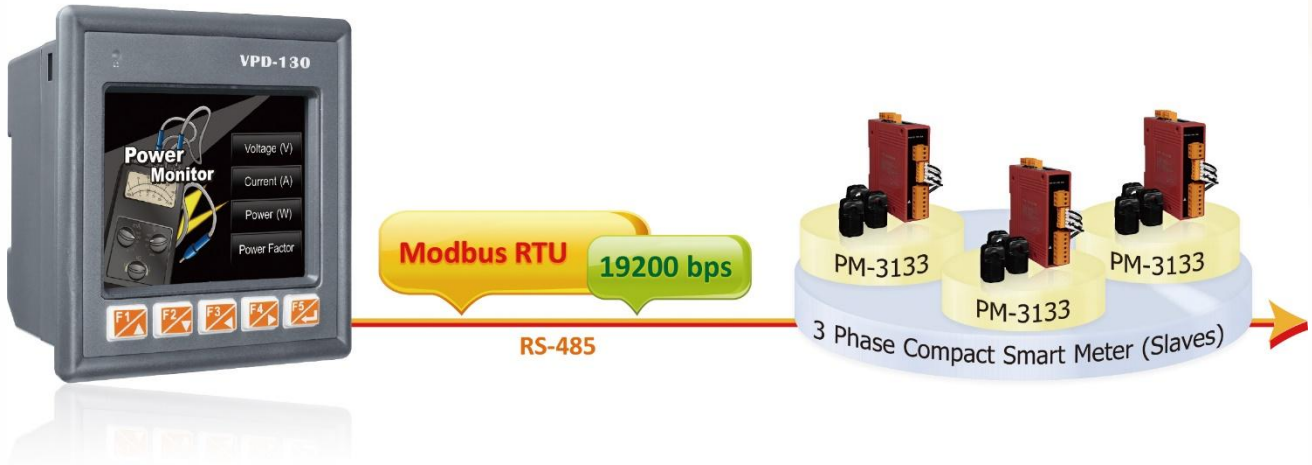

**B: Two Masters Sharing One Slave (via tSH-735):**

This feature allows two master devices, connected to different serial ports, to share access to the same slave device.

- **Modbus Mode:** Converts between the Modbus RTU and Modbus ASCII protocols.
- **Raw Data Mode:** Supports DCON or other query-response protocols.
- **Flexible Communication:** Different **baud rates** and **data formats** can be configured for each serial port independently.
- **Built-in Cache:** The caching mechanism reduces communication load by eliminating duplicated queries when both master devices request the same information.

VPD-14x/VPD-13x  
Master #1

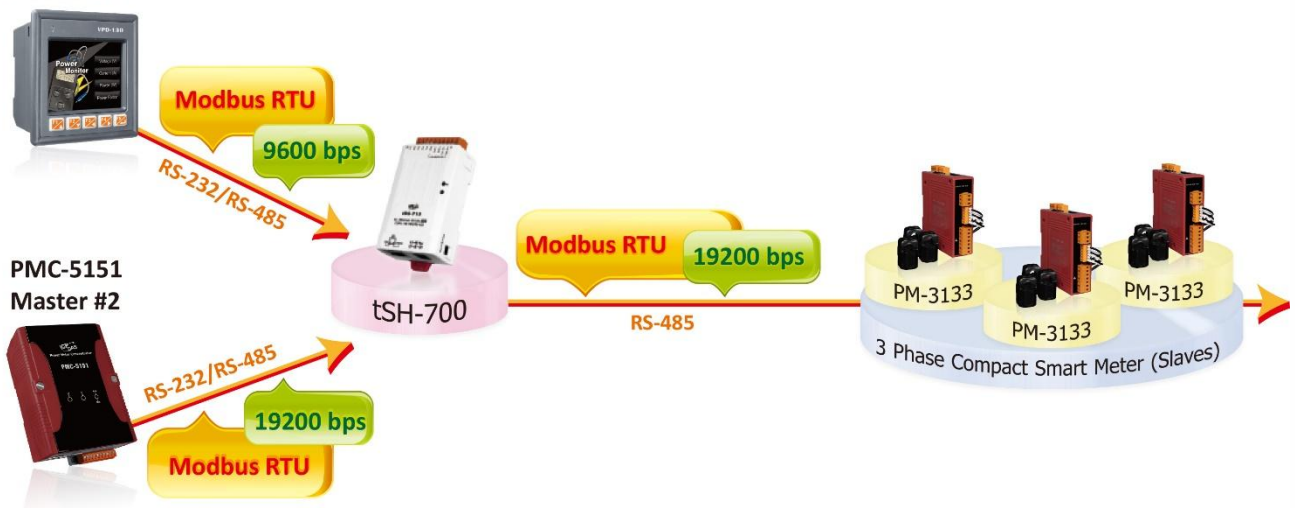

**Q15. How do I change the units of the [PT Ratio] and [CT Ratio] register vales?****Answer:**

Users can change the unit of the [PT Ratio] and [CT Ratio] register values by setting the values of the [PT Ratio Scale] and [CT Ratio Scale] registers.

The actual unit of the [PT Ratio] and [CT Ratio] is calculated using the following formula, which is based on powers of 10:

$$\text{Unit of Ratio Value} = 10^{(X-10)}, \quad 6 \leq X \leq 14,$$

**X is the register value of [PT Ratio Scale] or [CT Ratio Scale]**

Examples:

- When **[PT Ratio Scale] = 8**, the unit of PT Ratio is **0.01** ( i.e.,  $10^{(8-10)} = 10^{(-2)}$  )
- When **[CT Ratio Scale] = 10**, the unit of CT Ratio is **1** ( i.e.,  $10^{(10-10)} = 10^0$  )

**Q16. What is the difference between the [PF\_x] and [SignedPF\_x] registers?****Answer:**

The **PF\_a**, **PF\_b**, **PF\_c**, **PF\_total** registers provide **unsigned power factor** values, ranging only from **0 to +1**.

- [0x110A-0x110B]: Phase A's unsigned PF (float)
- [0x111C-0x111D]: Phase B's unsigned PF (float)
- [0x112E-0x112F]: Phase C's unsigned PF (float)
- [0x1140-0x1141 ]: Total unsigned PF (float)

The **SignedPF\_a**, **SignedPF\_b**, **SignedPF\_c**, and **SignedPF\_total** registers provide signed power factor values(float), which indicate the direction of power flow based on the signs of active power (P) and reactive power (Q):

- [0x11A2, 0x11A3]: Phase A's signed PF (float)
- [0x11A4, 0x11A5]: Phase B's signed PF (float)
- [0x11A6, 0x11A7]: Phase C's signed PF (float)
- [0x11A8, 0x11A9]: Total signed PF (float)

**Signed PF values follow these rules based on power quadrants:**

- **Quadrant 1:**  $P > 0, Q > 0 \rightarrow$  PF range: **0 to +1**
- **Quadrant 2:**  $P < 0, Q > 0 \rightarrow$  PF range: **-2 to -1**
- **Quadrant 3:**  $P < 0, Q < 0 \rightarrow$  PF range: **-1 to 0**
- **Quadrant 4:**  $P > 0, Q < 0 \rightarrow$  PF range: **+1 to +2**

**Q17. Why does using the 3P3W 2CT method to measure kWh in a 3P3W system cause larger errors??**

**Answer:**

The 3P3W 2CT method helps reduce installation cost, but its calculation principle assumes a balanced three-phase load. Therefore, significant errors may occur under the following conditions:

**1. Three-phase imbalance**

- If loads are unbalanced or single-phase loads dominate, measurement errors will occur.

**2. Harmonic distortion**

- Harmonics distort voltage and current waveforms. Uneven harmonic distribution across phases increases errors.

**3. Wiring or configuration errors**

- Incorrect CT direction, phase sequence, or meter settings directly affect kWh accuracy.

**4. Low power factor condition**

- When the power factor drops below 0.5, one phase in the 2CT method may momentarily measure negative kWh.
- If the meter is configured to use absolute kWh accumulation, reverse power is still accumulated as positive energy, which causes overestimation of total energy.

**Conclusion:**

The 3P3W 2CT method is only suitable for **balanced three-phase systems with low harmonic distortion**. For unbalanced loads or systems with significant harmonics, the **3P3W 3CT method** is recommended for accurate measurement.

**Q18. What is the function of Modbus register [Enable Phase B Zero Voltage]?****Answer:**

The Modbus register [Enable Phase B Zero Voltage] is applicable only when the wiring mode is **3P3W-2CT**.

- When the register is set to **Enable (Value = 1)**, the voltage value of Phase B will be forced to zero.
- When the register is set to **Disable (Value = 0)**, the actual voltage value of Phase B will be displayed.

This function prevents misinterpretation of Phase B voltage under 3P3W-2CT wiring.

**Q19. I would like to read voltage and current values via PDOs, but the manual does not list the corresponding PDO COB-IDs. How can I read these values? (Applicable to PM-3133-CPS / PM-3133P-CPS / PM-3133-RCT-CPS)****Answer:**

The reason and solution are as follows:

- In the standard CANopen protocol, **only PDOs 1, 2, 3, and 4 have default PDO COB-IDs**.
- The voltage and current values are mapped to **PDOs 5, 6, 7, and 8**, which do not have default COB-IDs.
- Therefore, users must manually configure the PDO COB-IDs for the following PDO Communication Parameter objects:
  - PDO 5 → Object **0x1804-01**
  - PDO 6 → Object **0x1805-01**
  - PDO 7 → Object **0x1806-01**
  - PDO 8 → Object **0x1807-01**
- After the PDO COB-IDs are configured, the voltage and current values can be received via the assigned COB-IDs.